



SOLUTIONS FOR BETTER PERFORMING TOOLS

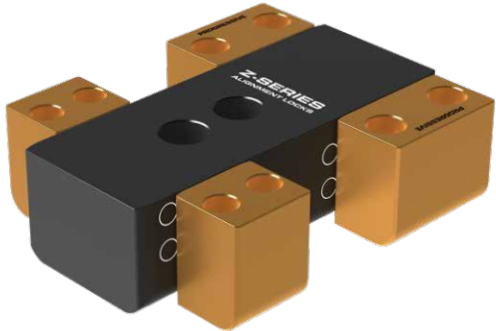
CATALOG VERSION 16 RECENTLY ADDED PRODUCTS



**Side Action Components
Section G**



**Runner Turn Offs
Gate Inserts
Section D**



**Bar Locks
Top Machine Style
Section C**



**Black Nitride
Greaseless
Components
Sections A & B**



**ProFile Asset Tracking
and Monitoring
Section F**



**Toolroom Innovations
Section M**

**Customer Service
1-800-269-6653 | 1-847-487-1000**

www.procomps.com

ABOUT PROGRESSIVE

Progressive's roots are in mold building and mold design, so rather than function simply as a reseller, our team of engineers develops and supports every item and service within our product range:



PRECISION STANDARDS

Tight Tolerances Maintained.
Proven Performance Achieved.



TECHNOLOGY AND SUPPORT

Invented Mold Monitoring.
Advancing for Growing Needs.



MOLD-READY™ COMPONENTS

Made-To-Order Components.
Proprietary Treatments Available.

PROGRESSIVE'S COMMITMENT

With a foundation in the mold business, we feel a responsibility to provide every customer with best-in-class products and service levels:

- Products that meet expectations for quality, value, and performance.
- Knowledgeable and helpful Customer Service and Technical Support staff.
- Prompt resolution to order issues and billing questions.

If there is any way in which we can serve your needs better, contact us or any Progressive Team Member.



Glenn Starkey, President
glenn.starkey@procomps.com

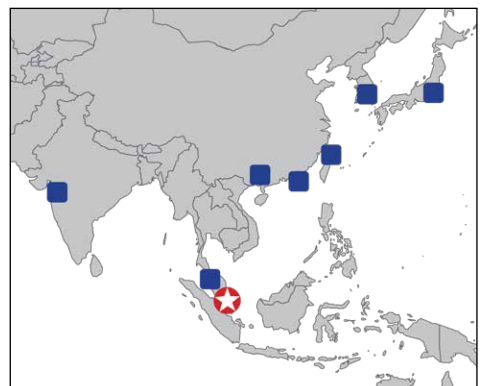
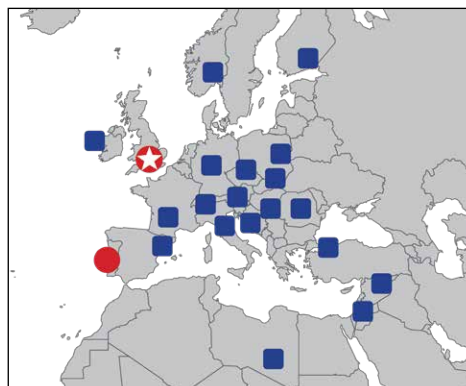
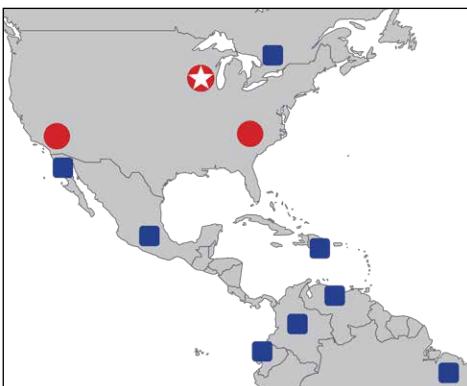
Don Starkey, Chairman
don.starkey@procomps.com

SERVICE CAPABILITY

Wherever your tooling is built or run, Progressive Components is positioned nearby:

- Stocking locations in Illinois, California, and South Carolina.
- Tech and service support in Singapore, Portugal, England, Germany, Mexico, and the USA.

We serve a global industry with borderless Account Management that operates as one integrated network.



★ Regional Headquarters ● Stocking Locations ■ Distribution Partners





LIFTERS UNDERCUT RELEASE
 C-Series Lifters
 FlexiCores
 Guides & Keys
 ModuLifters
 Spherical Bushings
 UniLifters
 Versa-Lifters

ELECTRICAL COMPONENTS
 Cables
 Hot Sprue Bushings
 KO Switches
 Recessed Connectors
 Plate Position Switches
 Thermocouples
 Wire Channels

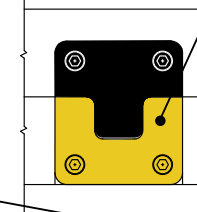
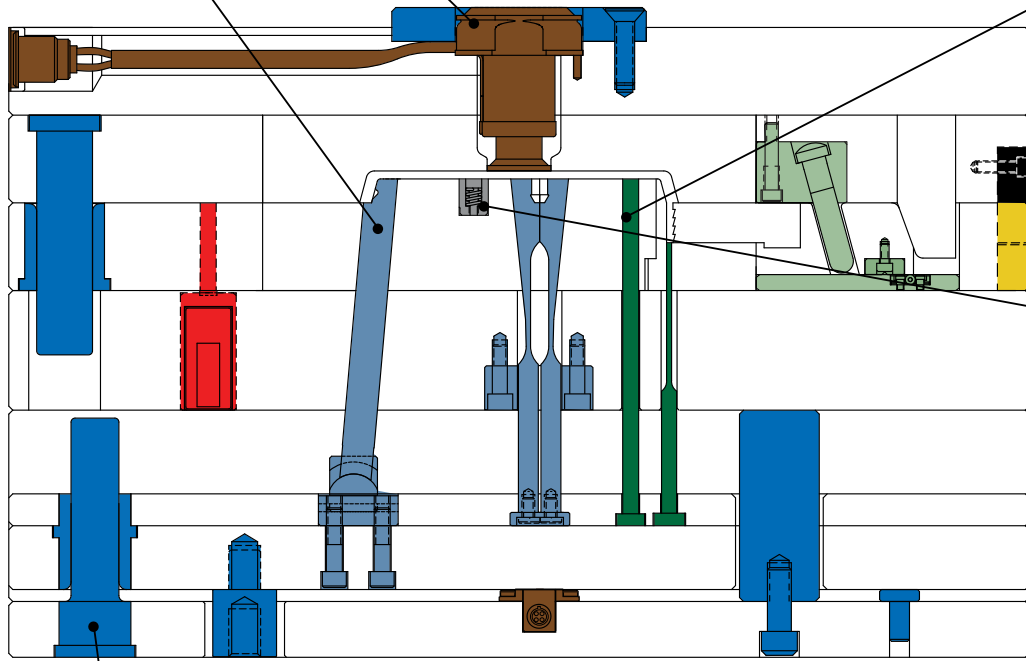
RAPID TOOLING INSERTS
 Clamps
 Frames
 Inserts
 RTI Pins & Bushings
 RTI Support Pillars
 T-Handles

TOOLROOM INNOVATIONS
 Mold Light Bar
 Fin Tip Nozzles
 Nozzle Caddie
 Mold Finish Guide
 RhinoFeet
 Status Tags
 Synthetic Mold Grease
 Toolroom Bench

MOLD MONITORING
 Asset Tags & Plates
 CounterView
 CV/CVe Cover Plates
 CVe Real-Time Monitor
 OnDemand CVe
 Insulator Block/Bracket
 ProFile Real-Time
 ProFile Asset Mgt.
 System Cooling
 System Cooling Test Rig

EJECTOR PINS CORE PINS SLEEVES
 Black Nitride Ej Pins
 Blade Ejectors
 Core Pins & Retainers
 Ejector Pins
 Ejector Sleeves
 Metric Pins/Sleeves/Blades
 Mold-Ready Pins
 Return Pins
 Sleeve Extensions
 Thin Wall Sleeves
 TI Pins
 UltraPins

ALIGNMENT LOCKS
 Bar Locks & Guides
 Black Nitride Side Locks
 Cavity Interlocks
 Guide Locks
 Needle Bearing Locks
 Radial Locks
 Shuttle Mold Locks
 Side Locks
 Taper Locks
 Taper Bar Locks
 Top Locks
 X-Series Locks



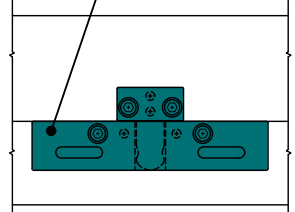
CAVITY COMPONENTS DATE MARKING
 Air Poppets
 Air Valves
 Date Stamps
 Date Plugs
 Gate Inserts
 Recycle Inserts
 Retro/Indexable Plugs
 Runner Turn Off

COLLAPSIBLE CORES EXPANDABLE CAVITIES
 DT Series C-Cores
 Expandable Cavities
 Grinding Rings
 MiniCores
 Retention Sleeves
 RT Series C-Cores

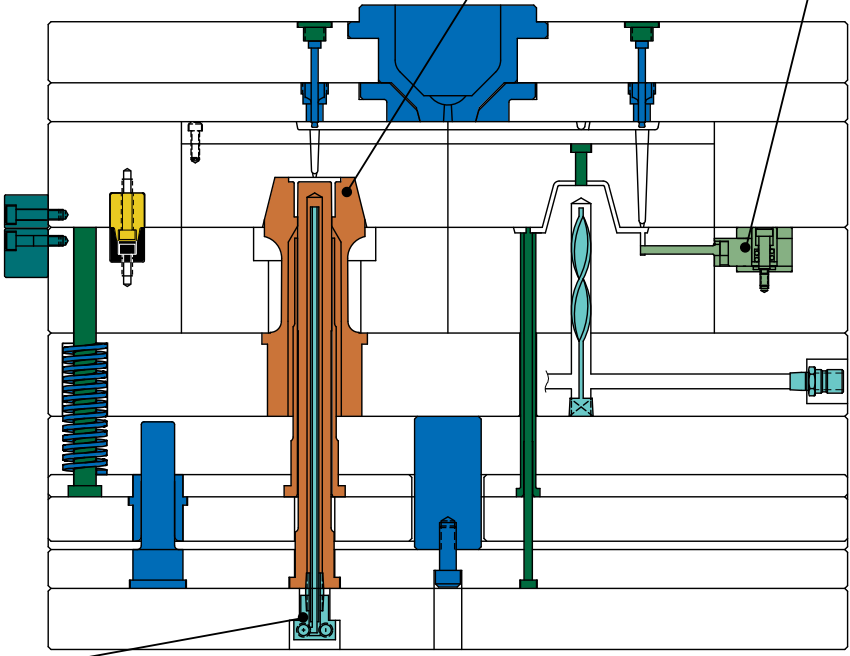
SLIDE COMPONENTS CAMACTIONS
 Angle Pins
 Angle Pin Holders
 CamActions
 CamAction Pins/Inserts
 Center Guides
 L-Gibs
 Square Gibs
 SRT Slide Retainers
 SRT Slide Lock Retainers
 Urethane Retainers
 Wear Strips
 Wear Plates

MOLD BASE COMPONENTS
 Black Nitride Leader Pins & Bushings
 Extended Sprues
 Front Loading Pins
 Guided Ej Bushings
 Guided Ejector Pins
 Guided Support Pillars
 Leader Pins
 Locating Rings/Shims
 PKO Extensions
 Puller Pins & Bushings
 Safety Straps
 Shoulder Bushings
 Spacers
 Springs
 Sprue Bushings
 Straight Bushings
 Stripper Bolts & Bushings
 Support Columns
 Support Pillars
 Stop Discs & Pins
 Tubular Dowels

PLATE SEQUENCE CONTROL
 Friction Pullers
 Plate Latch Locks
 Plate Accelerators
 Plate Retainers
 Roller Pullers
 StackKit












COOLING PRODUCTS
 Baffles (NPT/BSPT)
 Bubbler Base
 Cascades
 Clamps & Tape
 Connector Plugs
 Diverting Rods & Plugs
 Elbows
 Extension Plugs
 Hex & Piston Tubes
 Hose
 Hose Barbs
 Inlet Cascade Fittings
 Misc Brass Fittings
 O-Rings
 Safety Clips
 Threadless Plugs
 Tubes
 Water Blockers
 Water Jumpers








Product Description	Page	Product Description	Page	Product Description	Page
Adjustable Hex Nipples	E-28	Elbows: Hex Key	E-29	RTI® Straps	L-10
Air Valves & Poppets	D-18	Expandable Cavities	I-3	RTI® Support Pillars	L-9
Angle Pins	G-23	Extended Sprue Bushings	B-4	RTI® T-Handles	L-10
Angle Pin Holders	G-24	Extension Elbows	E-36	Runner Turn Off	D-2
Asset Tags & Plates	F-6	Extension Plugs	E-21	Safety Straps	B-32
Baffles	E-2	Extension Plugs: Keyed Connect	E-23	Shuttle Mold Sets	C-11
Baffles: Jumper	E-4	FlexiCore® System	H-18	Side Locks: Graphite Plugged	C-24
Baffles: Reverse Flow	E-5	Friction Pullers	J-14	Side Locks: Needle Bearing	C-23
Bar Locks: Inserted	C-9	Front Load Pins & Bushings	B-18	Side Locks: Steel	C-25
Bar Locks: Side Machine	C-4	Front Loading LP/B Guide Blocks	B-19	Side Locks: Z-Series®	C-10
Bar Locks: Side Machine Guides	C-5	Gate Inserts	D-4	Side Locks: X-Style, Z-Series®	C-11
Bar Locks: Top Machine Bars & Guides	C-6	Grease: Synthetic	M-8	Sleeve Extensions / Blanks	A-19
Bar Locks: X-Style	C-7	Guide Locks: Z-Series®	C-14	Socket Connectors	E-25
Black Nitride Ejector Pins	A-1	Guided Ejector Pins	B-10	Socket Connectors: Keyed Connect	E-27
Black Nitride Leader Pins	B-12	Hex Elbows: Female & Male	E-36	Socket Connector Safety Clips	E-27
Black Nitride Bushings	B-13	Hex Key Extension Pipes	E-28	Spacers	B-31
Black Nitride (Die Cast) Side Lock	C-21	Hose Barbs & Splicers	E-37	Spanner Wrench	B-17
Blade Ejectors: DIN	A-13	Hose: Push-Lok®	E-30	Spherical Bushings	H-9
Blade Ejectors: Inch	A-12	Hot Sprue Bushings	K-8	Springs	B-25
Bubbler Base	E-12	Inlet Cascades	E-13	Springs: Radial	C-15
Bushings: Guided Ejector	B-16	Insulator Block: External Mount	F-12	Springs: Urethane	B-24
Bushings: Shoulder	B-14	Insulator Block: Retrofit Bracket	F-13	Sprue Bushings	B-1
Bushings: Straight	B-15	Leader Pins: Inch	B-8	SRT™ Bases & Bushings	G-16
CamActions® (100-400 Series)	G-2	Leader Pins: Metric DIN	B-9	SRT™ Slide Retainers & Cleats	G-14
Cascade: Hex Key, Compact	E-10	Leader Pins: Shoulder Style / Guided	B-11	SRT™ Slide Lock Style Retainers	G-17
Cascade: High Flow	E-7	L-Gibs	G-22	StackKit® System	J-15
Cascade: Nipple Type	E-6	Lifter Guides	H-10	Status Tags	M-6
Cascade: Quick Coupler	E-11	Lifter Head Key	H-11	Stop Discs & Pins	B-31
Cascade: Rear Load Quick Coupler	E-9	Locating Rings	B-2	Stripper Bolt Bushings	B-29
Cascade: Rear Loading Nipple	E-8	Locating Ring Shims	B-3	Stripper Bolts	B-28
Cavity Interlocks: Flat Series	C-16	MiniLifter® Series	H-2	Square Gibs	G-18
Cavity Interlocks: Round Series	C-17	ModuLifter® System	H-12	Support Columns & Pucks	B-22
Center Guides	G-19	Mold Finish Guide	M-7	Support Pillars: Counterbored	B-20
Collapsible Cores: DT Series	I-1	Mold Light Bar	M-8	Support Pillars: Guided	B-23
Collapsible Cores: RT Series	I-2	Nozzle Caddie & Wrench	M-3	Support Pillars: Stainless Steel	B-21
Combination Hose Inserts	E-38	Nozzles: Fin Tip	M-2	Support Pillars: Threaded	B-20
Connector Plugs	E-24	O-Rings: Core Diameter Seal	E-18	Switch: Extension Block Assembly	K-5
Connector Plugs: Keyed	E-26	O-Rings: Core Face Seal	E-19	Switch: External Mount	K-3
Core Pin Retainers	A-20	O-Rings: Face Seal	E-17	Switch: KO™	K-1
Core Pins	A-14	Patch Cables	K-6	Switch: KO™ Single/Dual Ejector	K-2
CounterView®: Attachment Block	F-12	Pipe Check	E-1	Switch: Plate Position	K-4
CounterView®: R-Series	F-11	Pipe Nipples	E-30	Switch: Side Action	K-4
CounterView®: S-Series	F-10	PKO Extensions & Pucks	B-7	System Cooling™	F-15
Cover Plugs, Clamps & Tape	E-39	Plate Accelerators	J-13	System Cooling™ Test Rig	F-18
CounterView®/CvE Cover Plates	F-14	Plate Latch Locks: Cam Sequencing	J-1	Taper Locks: Counterbored	C-18
CvE Real-Time Monitor®	F-2	Plate Latch Locks: Cam Block	J-5	Taper Locks & Plates	C-19
CvE OnDemand®	F-7	Plate Retainers	J-8	Tees & Elbows	E-40
Date Plugs: Replacements	D-14	Plugs: Pipe	E-20	Thermocouples	K-7
Date Stamps: 20 Series	D-11	Plugs: Threadless	E-32	TI™ Pins	A-15
Date Stamps: CH Series	D-10	Plugs: Water Blocker™	E-31	Toolroom Bench	M-4
Date Stamps: Compact Locking	D-6	ProFile® Asset Management System	F-5	Top Locks: Internal	C-12
Date Stamps: D (Deep) Series	D-11	ProFile® Real-Time Monitoring	F-3	Top Locks: Needle Bearing	C-22
Date Stamps: FD Series	D-13	Puller Pins & Bushings	B-6	Top Locks: Z-Series®	C-13
Date Stamps: LG Series	D-16	Recessed Connectors	K-6	Tubes: High Flow & Hex Series	E-14
Date Stamps: Locking Series	D-7	Rectangular Taper Bar Locks	C-20	Tubes: Piston & Brass	E-16
Date Stamps: MicroDaters	D-15	Recycle Inserts	D-17	Tubular Dowels	B-30
Date Stamps: Multi-Daters	D-12	Reducers & Couplings	E-41	Two-Stage Ejectors	J-10
Date Stamps: RF Series	D-8	Return Pins	A-21	UltraPins®	A-10
Date Stamps: Tapered Series	D-9	RhinoFeet™	M-1	UniLifter® System	H-1
Diverting Rods & Plugs	E-33	RhinoToes™	M-1	Versa-Lifter™ System	H-7
Ejector Accelerators	J-12	Roller Pullers	J-7	Water Jumpers: Push-Lok® Series	E-34
Ejector Pins: Metric DIN	A-6	RTI® 08/09 Series	L-2	Water Jumpers: Swivel Type	E-35
Ejector Pins: Inch (H-13)	A-2	RTI® Complete	L-4	Wear Plates: Bronze	G-22
Ejector Pins: Inch (M-2)	A-4	RTI® Complete Cavity & Core Inserts	L-5	Wear Strips	G-20
Ejector Pins: Metric JIS	A-8	RTI® Frame Clamps	L-10	Wear Plates	G-21
Ejector Sleeves: Inch	A-16	RTI® Frame Sprue Bushings	L-9	Wire Channel Inserts	K-7
Ejector Sleeves: Metric DIN	A-17	RTI® 08/09 Frames	L-7		
Ejector Sleeves: Thin Wall (Inch)	A-18	RTI® Pins & Bushings	L-8		



EJECTOR PINS CORE PINS SLEEVES				
	Black Nitride Ejector Pins	Ejector Pins: Straight Inch	Ejector Pins: Shoulder	Ejector Pins: Straight DIN
	Prefix: EP	Prefix: EP, EPM	Prefix: EP, EPM	Prefix: EPD
Catalog # Prefix	Page: A-1	Page: A-2 & A-4	Page: A-3 & A-5	Page: A-6
Catalog Page				






				
Ejector Pins: Shld. DIN	Ejector Pins: Straight JIS	Ejector Pins: Shoulder JIS	UltraPins: Straight	UltraPins: Shoulder
Prefix: EPD	Prefix: EPJ	Prefix: EPJ	Prefix: EPL	Prefix: EPL
Page: A-7	Page: A-8	Page: A-9	Page: A-10	Page: A-11






				
Blade Ejectors: Inch	Blade Ejectors: DIN	Core Pins	TI Pins	Ejector Sleeves: Inch
Prefix: BE	Prefix: BE	Prefix: CP	Prefix: TI	Prefix: ES
Page: A-12	Page: A-13	Page: A-14	Page: A-15	Page: A-16




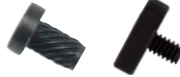

				
Ejector Sleeves: DIN	Thin Wall Sleeves	Sleeve Extensions	Core Pin Retainers	Return Pins
Prefix: ESD	Prefix: ESTW	Prefix: SXT	Prefix: CPR	Prefix: RP
Page: A-17	Page: A-18	Page: A-19	Page: A-20	Page: A-21





MOLD BASE COMPONENTS				
	Sprue Bushings	Locating Rings & Shims	Extended Sprues	Puller Pins & Bushings
	Prefix: SPR	Prefix: LR	Prefix: ESB, RX	Prefix: PP, PPB
Catalog # Prefix	Page: B-1	Page: B-2	Page: B-4 & B-5	Page: B-6
Catalog Page				






				
PKO Extensions	Leader Pins: Inch	Leader Pins: DIN	Guided Ejector Pins	Leader Pins: Shoulder
Prefix: PH, PKP	Prefix: LP	Prefix: LPD	Prefix: GEP, LP	Prefix: SLP
Page: B-7	Page: B-8	Page: B-9	Page: B-10	Page: B-11

				
Black Nitride Leader Pins	Black Nitride Bushings	Bushings: Shoulder	Bushings: Straight	Guided Ejector Bushings
Prefix: LP	Prefix: STL, GEB	Prefix: SAB, SHB, SGP, STL	Prefix: STB, STGP	Prefix: GEB, GGP, GQC
Page: B-12	Page: B-13	Page: B-14 & B-15	Page: B-15	Page: B-16 & B-17

				
Front Load Pins/Bushings	Guide Blocks	Support Pillars/Columns	Guided Support Pillars	Urethane Springs
Prefix: FLPB	Prefix: GBK	Prefix: SP, SPH	Prefix: GESP	Prefix: US
Page: B-18	Page: B-19	Page: B-20 - B-22	Page: B-23	Page: B-24





				
Springs	Stripper Bolts/Bushings	Tubular Dowels	Stop Discs/Pins/Spacers	Safety Straps
Prefix: MS, HS	Prefix: SBLT, SBB	Prefix: TD	Prefix: SD, STP, SPC	Prefix: SAFT
Page: B-25 - B-27	Page: B-28 & B-29	Page: B-30	Page: B-31	Page: B-32

ALIGNMENT LOCKS				
	Bar Locks: Side Machine	Bar Locks: Top Machine	Bar Locks: X-Style	Bar Locks: Inserted
	Prefix: BLB, BLG	Prefix: BLBT, BLGT	Prefix: BLBX	Prefix: BLN, BLS
Catalog # Prefix	Page: C-4 & C-5	Page: C-6	Page: C-7	Page: C-9
Catalog Page				

				
Side Locks	Side Locks: X-Style	Top Locks: Internal	Top Locks	Guide Locks
Prefix: SL, SLC, SLM	Prefix: SLX	Prefix: TL, TLM	Prefix: TL, TLM	Prefix: GL, GLM
Page: C-10	Page: C-11	Page: C-12	Page: C-13	Page: C-14

				
Radial Springs	Cavity Interlocks: Flat	Cavity Interlocks: Round	Taper Locks: C'Bored	Taper Locks & Plates
Prefix: RS	Prefix: CF, CFM	Prefix: CRS, CRSM	Prefix: TLC	Prefix: MTL, FTL, TLP
Page: C-15	Page: C-16	Page: C-17	Page: C-18	Page: C-19

				
Rect. Taper Bar Locks	Die Cast (BN) Side Lock	Needle Bearing Locks	Side Locks: Graphite	Side Locks: Steel
Prefix: MTBL, FTBL	Prefix: SL	Prefix: SLR, SLRM, TLR	Prefix: SLPM	Prefix: SLS, SLMS
Page: C-20	Page: C-21	Page: C-22 & C-23	Page: C-24	Page: C-25

CAVITY COMPONENTS, DATE MARKING				
	Runner Turn Off	Gate Inserts	Locking Detent Series	RF Series
	Prefix: RTO	Prefix: GT	Prefix: DN, DTN	Prefix: DF
Catalog # Prefix	Page: D-2	Page: D-4	Page: D-6 & D-7	Page: D-8
Catalog Page				

				
Tapered Series	CH & D Series	20 Series	Multi-Daters	FD Series
Prefix: DTPR	Prefix: DC	Prefix: DL	Prefix: DMD	Prefix: DFD
Page: D-9	Page: D-10	Page: D-11	Page: D-12	Page: D-13



Retro & Indexable Plugs	MicroDatars	LG Series	Recycle Inserts	Air Poppets & Valves
Prefix: DP, DXP	Prefix: MD	Prefix: DLB, DLS	Prefix: RI, RIS	Prefix: AV, APV
Page: D-14	Page: D-15	Page: D-16	Page: D-17	Page: D-18 & D-19

COOLING PRODUCTS



Pipe Check	Baffles	Jumper Baffles	Reverse Flow Baffles
Prefix: PC	Prefix: SB, TB	Prefix: JBA	Prefix: RFB
Page: E-1	Page: E-2 & E-3	Page: E-4	Page: E-5



Cascade: Nipple Type	Cascade: High Flow	Cascade: Rear Load	Cascade: RL Quick Cplr	Cascade: Hex Key/Comp.
Prefix: NC	Prefix: HFC	Prefix: RLN	Prefix: RLQC	Prefix: HKC, CC
Page: E-6	Page: E-7	Page: E-8	Page: E-9	Page: E-10



Cascade: Quick Coupler	Bubbler Base	Inlet Cascade	Metric Tubes: High Flow	Tubes: High Flow, Hex
Prefix: QC	Prefix: BBL	Prefix: CF	Prefix: HFTM, HEXM	Prefix: HFT, HEXT
Page: E-11	Page: E-12	Page: E-13	Page: E-14	Page: E-15



Tubes: Piston, Brass	O-Rings	Pipe Plugs	Extension Plugs	Connector Plugs
Prefix: PT, T	Prefix: OR	Prefix: BR, ST, SS	Prefix: Numeral	Prefix: Numeral
Page: E-16	Page: E-17	Page: E-20	Page: E-21 - E-23	Page: E-24



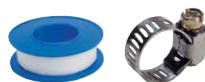
Socket Connectors	Connector Plugs: Keyed	Socket Conn: Keyed	Safety Clips	Adjustable Hex Nipples
Prefix: SC	Prefix: Numeral, Suffix: -K	Prefix: SC, Suffix: -K	Prefix: SC	Prefix: APN
Page: E-25	Page: E-26	Page: E-27	Page: E-27	Page: E-28



Hex Key Ext Pipes	Elbows: Hex Key	Pipe Nipples	Push-Lok Hose	Plugs: Water Blockers
Prefix: HKEPN	Prefix: HK, HKEE, HKL	Prefix: BPN, GPN	Prefix: WJH	Prefix: WB
Page: E-28	Page: E-29	Page: E-30	Page: E-30	Page: E-31



Plugs: Threadless	Diverting Rods & Plugs	Water Jumpers	Water Jumpers: Swivel	Elbows: Hex, Extension
Prefix: TWP, TAP, TDP	Prefix: D, DR	Prefix: WJ	Prefix: WJ	Prefix: HELS, HELB
Page: E-32	Page: E-33	Page: E-34	Page: E-35	Page: E-36



Hose Barbs & Splicers	Comb. Hose Inserts	Clamps & Tape	Tees & Elbows	Reducers & Couplings
Prefix: MB, FB, HS	Prefix: Numeral	Prefix: CP, HC, TT	Prefix: T, MT, ELS, EL, ELA	Prefix: RB, MR, C, HN
Page: E-37	Page: E-38	Page: E-39	Page: E-40	Page: E-41

MOLD MONITORING



	CVe Real-Time Monitor	ProFile: Real-Time	Real-Time Cables	ProFile: Asset Mgt
Catalog # Prefix	Prefix: CVE		Prefix: CVEL	
Catalog Page	Page: F-2	Page: F-3	Page: F-4	Page: F-5

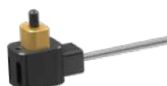


Asset Tags & Plates	CVe OnDemand	OnDemand Software	CounterView: S-Series	CounterView: R-Series
Prefix: AMTG	Prefix: CVE		Prefix: CVPL, CVPLHT	Prefix: CVR-A, CVR-B
Page: F-6	Page: F-7	Page: F-9	Page: F-10	Page: F-11



Insulator Blocks	CV/CVe Cover Plates	System Cooling	System Cooling Portable Cart	System Cooling Test Rig
Prefix: CV, CVMM, CVRA	Prefix: CV	Prefix: SCM	Prefix: SCP	Prefix: SCTR
Page: F-12 & F-13	Page: F-14	Page: F-15	Page: F-17	Page: F-18

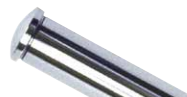
SLIDE COMPONENTS CAMACTIONS



	CamAction 100 Series	CamAction 200 Series	CamAction 250 Series	CamAction 300/350
Catalog # Prefix	Prefix: CA, CAME	Prefix: CA, CAME	Prefix: CA, CAME	Prefix: CA, CAME
Catalog Page	Page: G-2	Page: G-3	Page: G-4	Page: G-5 - G-8











CamAction 400 Series	Slide Retainers	SRT Bases & Bushings	Square Gibs	Center Guides
Prefix: CA	Prefix: SRT, SRTLK	Prefix: SRTBA, SRTBU	Prefix: SG	Prefix: CG
Page: G-9	Page: G-14 - G-17	Page: G-16	Page: G-18	Page: G-19



Wear Strips	Wear Plates	Bronze Plates & L-Gibs	Angle Pins	Angle Pin Holders
Prefix: WS	Prefix: WP	Prefix: WP, LGIB	Prefix: AP	Prefix: APH
Page: G-20	Page: G-21	Page: G-22	Page: G-23	Page: G-24 & G-25



LIFTERS UNDERCUT RELEASE				
	UniLifters: UL-Series	UniLifters: C-Series	Versa-Lifter System	Spherical Bushings
	Catalog # Prefix Prefix: CB, UC, TG	Catalog # Prefix Prefix: CB, CC, CG	Catalog # Prefix Prefix: UGV, SGV, CBV	Catalog # Prefix Prefix: LSB
Catalog Page	Page: H-1 - H-4	Page: H-1 - H-5	Page: H-7 & H-8	Page: H-9

			
Lifter Guides	Lifter Head Key	ModuLifter System	FlexiCore System
Catalog # Prefix Prefix: LG, SGV	Catalog # Prefix Prefix: LHK	Catalog # Prefix Prefix: MLB, MLC, MLR, MLH	Catalog # Prefix Prefix: FCA, FCR, FCDA
Catalog Page Page: H-10	Catalog Page Page: H-11	Catalog Page Page: H-12 - H-17	Catalog Page Page: H-18 - H-23





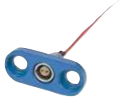



COLLAPSIBLE CORES EXPANDABLE CAVITIES			
	C-Cores: DT Series	C-Cores: RT Series	Expandable Cavities
	Catalog # Prefix	Catalog # Prefix	Catalog # Prefix
Catalog Page	Page: I-1	Page: I-2	Page: I-3

PLATE SEQUENCE CONTROL				
	Latch Locks: Cam Seq.	Latch Locks: Cam Block	Roller Pullers	Plate Retainers
	Catalog # Prefix Prefix: PLC, PLCM	Catalog # Prefix Prefix: PLC, PLCM	Catalog # Prefix Prefix: RPL	Catalog # Prefix Prefix: PRT
Catalog Page	Page: J-1	Page: J-5	Page: J-7	Page: J-8

				
Two-Stage Ejectors	Ejector Accelerators	Plate Accelerators	Friction Pullers	StackIt System
Catalog # Prefix Prefix: PLN	Catalog # Prefix Prefix: EJA	Catalog # Prefix Prefix: ACCPM	Catalog # Prefix Prefix: FP	Catalog # Prefix Prefix: SK
Catalog Page Page: J-10	Catalog Page Page: J-12	Catalog Page Page: J-13	Catalog Page Page: J-14	Catalog Page Page: J-15 - J-18

ELECTRICAL COMPONENTS				
	KO Switches	External Mount Switch	Plate Position Switch	Side Action Switch
	Catalog # Prefix Prefix: SWKO	Catalog # Prefix Prefix: SWXM	Catalog # Prefix Prefix: SWPPS	Catalog # Prefix Prefix: SWSA
Catalog Page	Page: K-1 & K-2	Page: K-3	Page: K-4	Page: K-4

				
Patch Cables	Recessed Connectors	Thermocouples	Wire Channel Inserts	Hot Sprue Bushings
Catalog # Prefix Prefix: ECCA	Catalog # Prefix Prefix: ECRC	Catalog # Prefix Prefix: TC	Catalog # Prefix Prefix: WC	Catalog # Prefix Prefix: BX
Catalog Page Page: K-6	Catalog Page Page: K-6	Catalog Page Page: K-7	Catalog Page Page: K-7	Catalog Page Page: K-8 & K-9

RAPID TOOLING INSERTS				
	Rapid Tooling Inserts	RTI: Complete	Cavity & Core Inserts	Frame
	Catalog # Prefix	Prefix: RTS, RTL, RTT	Prefix: RTLP	Prefix: RCI, RCIA
Catalog Page	Page: L-1 - L-6	Page: L-4	Page: L-5	Page: L-7

				
Pins & Bushings	Frame Sprue Bushing	Support Pillars	Straps & T-Handle	Frame Clamp
Prefix: RLP, RSB, RGEb	Prefix: RFS	Prefix: RSP	Prefix: MS, T	Prefix: RFC
Page: L-8	Page: L-9	Page: L-9	Page: L-10	Page: L-10

TOOLROOM INNOVATIONS				
	RhinoFeet™	RhinoToes™	Fin Tip Nozzles	Nozzle Caddie/Wrench
	Catalog # Prefix	Prefix: RHF	Prefix: RHT	Prefix: NZFT
Catalog Page	Page: M-1	Page: M-1	Page: M-2	Page: M-3

				
Toolroom Bench	Status Tags	Mold Finish Guide	Mold Light Bar	Synthetic Grease
Prefix: TRB	Prefix: ST	Prefix: LIT	Prefix: MLB	Prefix: SYN
Page: M-4	Page: M-6	Page: M-7	Page: M-8	Page: M-8

Progressive Components International Corporation has products that are protected by numerous patents, design patents, international patents and other patents pending. Contact Progressive Components with any inquiries regarding potential Intellectual Property concerns or violations.

Progressive Components®, ///®, ///Pro®, CADalog®, CamAction®, CounterView®, Cve®, Cve Monitor®, Cve OnDemand®, Cve Live®, PC/Mold®, ProFile®, ProComps®, ProSpec®, Rapid Tooling Insert®, RTI®, SRT®, StackIt®, ToolingDocs®, UltraPin®, UniLifter®, ModuLifter® and Z-Series® are registered U.S. and/or international trademarks. Bubbler Base™, FlexiCore™, Inlet Cascades™, Micro-Dater™, MiniLifter™, PKO™, Puller Pins™, QC™, Roller Pullers™, TI™, System Cooling™, KO™, Versa-Lifter™, Water Blocker™, Mold-Ready™, RhinoFeet™, RhinoToes™, and the Progressive Components logo are U.S. trademarks and numerous registered and pending international trademarks are the property of Progressive Components International Corporation.

AutoCAD® and Mechanical Desktop® are registered trademarks and DXF™ is a trademark of Autodesk, Inc.; Windows® is a trademark of Microsoft Corp.; Push-Lok® is a trademark of Parker Hannifin Corp.; PCS® is a trademark of PCS Company; CUMSA® is a trademark of CUMSA of Spain; DME® is a trademark of D-M-E Company; SolidWorks® is a registered trademark of Dassault Systèmes SolidWorks Corp; MiniCore®, C-Core®, and Ex-Cav® are registered trademarks of Roehr Tool Solutions; RHINOFOOT® is a trademark of Rhino Visions LLC; Viton® is a registered trademark of The Chemours Company FC, LLC / DuPont and related parties; TORX® is a registered trademark of Camcar Innovations; Molex® is a registered trademark of Molex, LLC; Holo-Krome® is a registered trademark of Fastenal IP Company; Caldie® is a registered trademark of Uddeholms AB; Mastip™ nozzle systems are protected by numerous registered designs, patents, and international patents pending.

©2024 Progressive Components International Corporation
 Unauthorized reproduction, distribution, or display of any portion of this printed or online catalog is prohibited.
 Printed in USA.



ORDERING INFORMATION

- HOURS:** Monday-Friday 7:00am-7:00pm (Central Time)
- PHONE ORDERS:** North America (Canada, Mexico, USA) toll-free: 1-800-269-6653 | International: 1-847-487-1000
- FAX ORDERS:** North America (Canada, Mexico, USA) toll-free: 1-800-462-6653 | International: 1-847-487-1027
- INTERNET ORDERS:** Orders may be placed via our website: www.procomps.com or via e-mail to customerservice@procomps.com.
- PICK-UP ORDERS:** Orders may be picked up at Regional Service Centers, subject to product availability.
- WALK-IN ORDERS:** Walk-in orders are accepted and processed immediately, subject to product availability.

DELIVERY

ROUTING/SHIP METHODS

- Parcel shipments will be routed via Progressive's carrier of choice, by default. An alternate carrier may be used at the customer's request if a valid account number is provided.
- In lieu of special instructions, packages will be routed best way per Progressive's past experience.
- Shipments are F.O.B. shipping point for orders within the continental United States.
- Package tracking is provided at no extra charge, though carrier is responsible for delays or damage.

QUOTED DELIVERY TIME FRAME

- All quoted ship dates are based upon the date the package is anticipated to leave the specified Service Center.

CREDIT AND PAYMENT

CREDIT

- A completed credit application will be processed within 3 business days upon receipt.
- Credit levels and payment terms may be adjusted periodically based upon actual payment history and purchasing requirements.
- Orders over \$10,000 may be subject to down payment requirements.

PAYMENT TERMS

Terms shall be granted in accordance with credit history and financial stability.

- Net 30 days: These terms are available only for customers whose credit/account is in good standing.
- Prepayment: Order ships upon receipt of funds.
- Special: Particular products (e.g. CVe Live/ProFile System, System Cooling, Customs and Specials, etc.) or types of orders (e.g. blanket POs) may warrant special payment terms to be specified and agreed to in writing.

PAYMENT METHODS

Payment is accepted in U.S. dollars in any form below, though actual payment history and/or financial status may limit options:

- Company Check: The cancelled check shall serve as receipt when made out and sent to: Progressive Components Intl. Corp., P.O. Box 734434, Chicago, IL 60673-4434
- Cash: Receipt will be issued to pick-up customers.
- EFT/ACH Payment: Contact Finance at billing@procomps.com for EFT/ACH routing instructions.
- Certified Funds: Money order, cashier's check, etc.
- Wired Funds: International customers are required to make payment via wired funds. Contact the Finance Department at billing@procomps.com for routing instructions.
- Credit Cards: VISA, MasterCard, and American Express accepted. Fees may be applied.

Notes:

- If particular payment methods are utilized due to poor credit rating, buyer is responsible for associated fees.
- International customers: Contact Customer Service for possible foreign currency and alternate payment methods. Customers will be responsible for wire transaction fees.
- Any reasonable costs incurred to collect past due accounts will be invoiced and due upon receipt, which may include legal expenses, collection fees and NSF charges.

WARRANTIES AND RETURNS

WARRANTIES

All products are warranted to the specifications listed in this catalog and at procomps.com and will be accepted for full credit or replacement should any significant deviations exist. In no event will Progressive Components be liable for anticipated profits or for incidental or consequential damages. Liability is limited to the price of the item sold, and no credit for any additional charges will apply unless previously agreed to in writing by appropriate Progressive personnel.

RETURNED GOODS PROCESS

Mold Components: Standard-sized components of current specifications are eligible for return with prior approval and an issued RMA number. All items are subject to inspection before issuance of a credit for the original or replacement product. Custom items, special order items, Daters after June of the indicated year, software, and all items at or beyond 60 days from the invoice date are not eligible for return.

System Cooling: Visible damage and defects must be reported within 14 days of receipt. For any warranty claim, customer must be able to demonstrate installation and use conforms with the User and Assembly Guide provided with delivery of the system and available online. Warranty claims must be received within 12 months of invoice date.

RESTOCKING FEES

A 10% restocking fee will be applied to all approved returned goods.

CLAIMS

Notification of shipping errors within 15 days upon receipt of goods will be promptly corrected.

THE FOREGOING WARRANTY IS EXCLUSIVE AND IN LIEU OF ALL OTHER WARRANTIES EXPRESSED OR IMPLIED, AS TO MERCHANTABILITY, FITNESS FOR A PARTICULAR PURPOSE, DESCRIPTION, QUALITY, PRODUCTIVENESS, OR OTHERWISE.

- Progressive Components reserves the right to make product improvements, changes, modifications or deletions to all products sold without incurring any liability and without advance notice.
- While every effort is made to ensure the listed dimensions and specifications in this catalog are accurate, Progressive Components does not guarantee their accuracy.
- The design guidelines and drawings are believed to be reliable, yet are provided for reference only.
- Information contained in this catalog supersedes all prior catalogs and printed sales/product information.
- Prices may be subject to change without notice. Visit www.procomps.com for all current pricing and product specifications.



EJECTOR PINS

CORE PINS, SLEEVES

SECTION A



Ejector Pins: Black Nitride	Ejector Pins: Straight Inch	Ejector Pins: Shoulder Inch	Ejector Pins: Straight M-2
Prefix: EP Suffix: -BN	Prefix: EP	Prefix: EP	Prefix: EPM
Page: A-1	Page: A-2	Page: A-3	Page: A-4



Ejector Pins: Shoulder M-2	Ejector Pins: Straight DIN	Ejector Pins: Shoulder DIN	Ejector Pins: Straight JIS
Prefix: EPM	Prefix: EPD	Prefix: EPD	Prefix: EPJ
Page: A-5	Page: A-6	Page: A-7	Page: A-8



Ejector Pins: Shoulder JIS	UltraPins (Straight & Shoulder)	Blade Ejectors: Inch	Blade Ejectors: DIN
Prefix: EPJ	Prefix: EPL	Prefix: BE	Prefix: BE
Page: A-9	Page: A-10 & A-11	Page: A-12	Page: A-13



Core Pins	TI Pins	Ejector Sleeves: Inch	Ejector Sleeves: DIN
Prefix: CP	Prefix: TI	Prefix: ES	Prefix: ESD
Page: A-14	Page: A-15	Page: A-16	Page: A-17

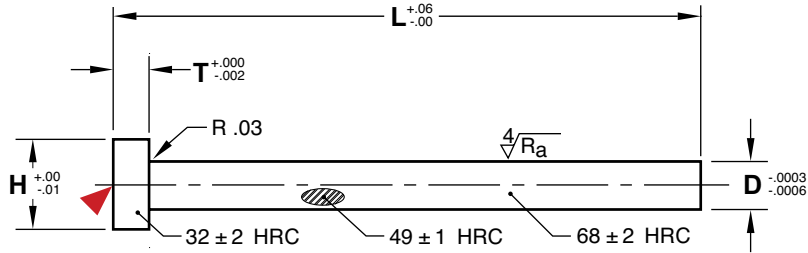


Thin Wall Sleeves	Sleeve Extensions	Core Pin Retainers	Return Pins
Prefix: ESTW	Prefix: SXT	Prefix: CPR	Prefix: RP
Page: A-18	Page: A-19	Page: A-20	Page: A-21



EJECTOR PINS BLACK NITRIDE

Progressive's Black Nitride Ejector Pins are proven to provide improved performance in greaseless, medical, and die cast environments.



M H-13 **H** Core: 48-50 HRC, Surface: 66-70 HRC **S** Black Nitride

CAD insertion point

D NOMINAL DIAMETER	H	T	L=10"		L=14"		L=18"		L=25"	
			D STANDARD	D .005 OVERSIZE	D STANDARD	D .005 OVERSIZE	D STANDARD	D .005 OVERSIZE	D STANDARD	D .005 OVERSIZE
7/64	.25	.125	EP109L10-BN	EP114L10-BN	—	—	—	—	—	—
1/8	.25	.125	EP125L10-BN	EP130L10-BN	—	—	—	—	—	—
9/64	.25	.125	EP141L10-BN	—	EP141L14-BN	EP146L14-BN	—	—	—	—
5/32	.28	.156	EP156L10-BN	EP161L10-BN	EP156L14-BN	EP161L14-BN	—	—	—	—
3/16	.37	.187	EP187L10-BN	EP192L10-BN	EP187L14-BN	EP192L14-BN	—	—	—	—
7/32	.40	.187	EP219L10-BN	EP224L10-BN	EP219L14-BN	EP224L14-BN	—	—	—	—
1/4	.43	.187	EP250L10-BN	EP255L10-BN	—	—	EP250L18-BN	EP255L18-BN	EP250L25-BN	—
9/32	.43	.250	EP281L10-BN	EP286L10-BN	—	—	EP281L18-BN	EP286L18-BN	EP281L25-BN	—
5/16	.50	.250	EP312L10-BN	EP317L10-BN	—	—	EP312L18-BN	EP317L18-BN	EP312L25-BN	EP317L25-BN
3/8	.62	.250	EP375L10-BN	EP380L10-BN	—	—	EP375L18-BN	EP380L18-BN	EP375L25-BN	EP380L25-BN
7/16	.68	.250	EP437L10-BN	EP442L10-BN	—	—	EP437L18-BN	EP442L18-BN	EP437L25-BN	EP442L25-BN
1/2	.75	.250	EP500L10-BN	EP505L10-BN	—	—	EP500L18-BN	—	EP500L25-BN	EP505L25-BN
9/16	.81	.250	EP562L10-BN	—	—	—	EP562L18-BN	—	EP562L25-BN	—
5/8	.87	.250	EP625L10-BN	—	—	—	EP625L18-BN	—	EP625L25-BN	—
3/4	1.00	.250	—	—	—	—	EP750L18-BN	—	EP750L25-BN	—
1	1.25	.250	—	—	—	—	EP1000L18-BN	—	EP1000L25-BN	—

ALTERNATIVE CONFIGURATIONS AVAILABLE

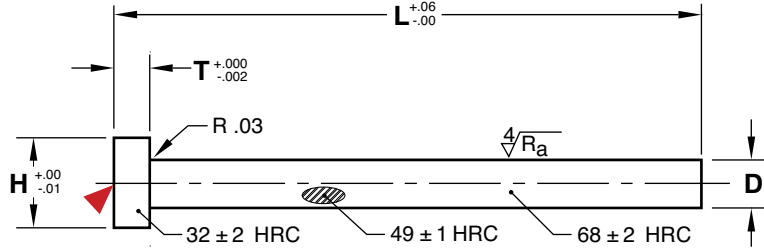
- Any standard Ejector Pin (Inch/DIN/JIS, straight and shoulder) can be ordered with the Black Nitride treatment for better performance. To order, specify "-BN" at the end of the catalog number. Ex. EP250L10-BN.
- Mold-Ready Ejector Pins can be supplied cut-to-length, keyed, and/or engraved at a standard price and delivery. Refer to page A-22 and procomps.com/mold-ready for more information.
- Made-to-order Pins can be quoted using the templates at procomps.com.



EJECTOR PINS
THROUGH-HARD PINS: STRAIGHT-INCH STANDARD



D Tolerances:	
Ø3/64 - Ø7/16	-.0004 -.0007
Ø15/32 and Larger	-.0004 -.0009



M H-13 **H** Core: 48-50 HRC, Surface: 66-70 HRC

▶ CAD insertion point

D NOMINAL DIAMETER	H	T	L=6"			L=10"			L=14"			L=18"			L=25"			L=39"		L=50"	
			D STANDARD	D STANDARD	D .005 OVERSIZE	D STANDARD	D STANDARD	D .005 OVERSIZE	D STANDARD	D STANDARD	D .005 OVERSIZE	D STANDARD	D STANDARD	D .005 OVERSIZE	D STANDARD	D STANDARD	D .005 OVERSIZE	D STANDARD	D STANDARD	D STANDARD	D STANDARD
1/32	.25	.125	EP031L6	—	—	—	—	—	—	—	—	—	—	—	—	—	—	—	—	—	—
3/64	.25	.125	EP047L6	—	—	—	—	—	—	—	—	—	—	—	—	—	—	—	—	—	—
1/16	.25	.125	EP062L6	EP062L10	—	—	—	—	—	—	—	—	—	—	—	—	—	—	—	—	—
5/64	.25	.125	EP078L6	EP078L10	—	—	—	—	—	—	—	—	—	—	—	—	—	—	—	—	—
3/32	.25	.125	EP094L6	EP094L10	—	—	—	—	—	—	—	—	—	—	—	—	—	—	—	—	—
7/64	.25	.125	EP109L6	EP109L10	EP114L10	—	—	—	—	—	—	—	—	—	—	—	—	—	—	—	—
1/8	.25	.125	EP125L6	EP125L10	EP130L10	EP125L14	EP130L14	EP125L18	—	EP125L25	—	—	—	—	—	—	—	—	—	—	—
9/64	.25	.125	—	EP141L10	—	EP141L14	EP146L14	—	—	—	—	—	—	—	—	—	—	—	—	—	—
5/32	.28	.156	EP156L6	EP156L10	EP161L10	EP156L14	EP161L14	EP156L18	—	EP156L25	—	—	—	—	—	—	—	—	—	—	—
11/64	.34	.187	—	EP172L10	—	EP172L14	EP177L14	—	—	—	—	—	—	—	—	—	—	—	—	—	—
3/16	.37	.187	EP187L6	EP187L10	EP192L10	EP187L14	EP192L14	EP187L18	—	EP187L25	—	—	—	—	—	—	—	—	—	—	—
13/64	.37	.187	—	EP203L10	—	EP203L14	EP208L14	—	—	—	—	—	—	—	—	—	—	—	—	—	—
7/32	.40	.187	EP219L6	EP219L10	EP224L10	EP219L14	EP224L14	—	—	EP219L25	—	—	—	—	—	—	—	—	—	—	—
15/64	.40	.187	—	EP234L10	—	EP234L14	EP239L14	—	—	—	—	—	—	—	—	—	—	—	—	—	—
1/4	.43	.187	EP250L6	EP250L10	EP255L10	EP250L14	EP255L14	EP250L18	EP255L18	EP250L25	—	—	—	—	—	—	—	—	—	—	—
17/64	.43	.250	—	EP266L10	—	EP266L14	EP271L14	—	—	EP266L25	—	—	—	—	—	—	—	—	—	—	—
9/32	.43	.250	EP281L6	EP281L10	EP286L10	EP281L14	EP286L14	EP281L18	EP286L18	EP281L25	—	—	—	—	—	—	—	—	—	—	—
19/64	.50	.250	—	EP297L10	—	EP297L14	EP302L14	—	—	—	—	—	—	—	—	—	—	—	—	—	—
5/16	.50	.250	EP312L6	EP312L10	EP317L10	EP312L14	EP317L14	EP312L18	EP317L18	EP312L25	EP317L25	EP312L39	EP312L50	—	—	—	—	—	—	—	—
21/64	.56	.250	—	EP328L10	—	EP328L14	EP333L14	—	—	EP328L25	—	—	—	—	—	—	—	—	—	—	—
11/32	.56	.250	EP344L6	EP344L10	EP349L10	EP344L14	EP349L14	—	—	EP344L25	—	—	—	—	—	—	—	—	—	—	—
23/64	.62	.250	—	EP359L10	—	EP359L14	EP364L14	—	—	—	—	—	—	—	—	—	—	—	—	—	—
3/8	.62	.250	EP375L6	EP375L10	EP380L10	EP375L14	EP380L14	EP375L18	EP380L18	EP375L25	EP380L25	EP375L39	EP375L50	—	—	—	—	—	—	—	—
25/64	.62	.250	—	—	—	EP390L14	EP395L14	EP390L18	—	—	EP395L25	—	—	—	—	—	—	—	—	—	—
13/32	.68	.250	EP406L6	EP406L10	EP411L10	EP406L14	EP411L14	EP406L18	—	EP406L25	—	—	—	—	—	—	—	—	—	—	—
27/64	.68	.250	—	—	—	EP422L14	EP427L14	—	—	—	—	—	—	—	—	—	—	—	—	—	—
7/16	.68	.250	EP437L6	EP437L10	EP442L10	EP437L14	EP442L14	EP437L18	—	EP437L25	—	—	—	—	—	—	—	—	—	—	—
29/64	.68	.250	—	—	—	EP453L14	EP458L14	—	—	—	—	—	—	—	—	—	—	—	—	—	—
15/32	.75	.250	—	EP469L10	EP474L10	—	EP474L14	EP469L18	—	EP469L25	—	—	—	—	—	—	—	—	—	—	—
31/64	.75	.250	—	—	—	EP484L14	EP489L14	—	—	—	—	—	—	—	—	—	—	—	—	—	—
1/2	.75	.250	EP500L6	EP500L10	EP505L10	EP500L14	EP505L14	EP500L18	—	EP500L25	EP505L25	EP500L39	EP500L50	—	—	—	—	—	—	—	—
17/32	.75	.250	—	—	—	EP531L14	EP536L14	—	—	EP531L25	—	—	—	—	—	—	—	—	—	—	—
9/16	.81	.250	EP562L6	EP562L10	—	EP562L14	—	EP562L18	—	EP562L25	—	—	—	—	—	—	—	—	—	—	—
5/8	.87	.250	EP625L6	EP625L10	—	EP625L14	—	EP625L18	—	EP625L25	—	—	—	—	—	—	—	—	—	—	—
11/16	.93	.250	—	EP687L10	—	—	—	EP687L18	—	EP687L25	—	—	—	—	—	—	—	—	—	—	—
3/4	1.00	.250	EP750L6	EP750L10	—	EP750L14	—	EP750L18	—	EP750L25	—	—	—	—	—	—	—	—	—	—	—
7/8	1.12	.250	—	EP875L10	—	EP875L14	—	EP875L18	—	EP875L25	—	—	—	—	—	—	—	—	—	—	—
1	1.25	.250	EP1000L6	EP1000L10	—	EP1000L14	—	EP1000L18	—	EP1000L25	—	—	—	—	—	—	—	—	—	—	—

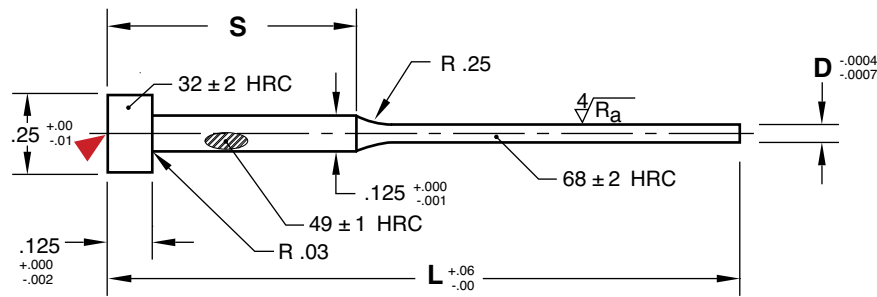
ALTERNATIVE CONFIGURATIONS AVAILABLE

- To order pins with the keys tangent to the diameter, add "-K" to the end of the catalog number. Ex. EP250L10-K.
- Mold-Ready Ejector Pins can be supplied cut-to-length, keyed, and/or engraved or with Black Nitride. Refer to page A-22 and procomps.com/mold-ready for more information.



EJECTOR PINS

THROUGH-HARD PINS: SHOULDER-INCH STANDARD



M H-13 **H** Core: 48-50 HRC, Surface: 66-70 HRC

CAD insertion point

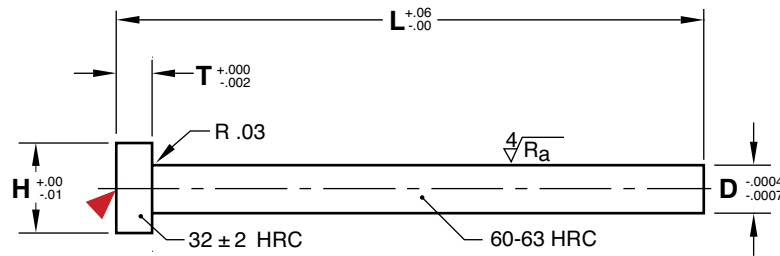
D NOMINAL DIAMETER	S SHOULDER LENGTH	L=6"		L=10"		L=14"	
		D STANDARD	D .005 OVERSIZE	D STANDARD	D .005 OVERSIZE	D STANDARD	D .005 OVERSIZE
1/32	1/2	EP031L6-05	EP036L6-05	—	—	—	—
	2	EP031L6-20	—	EP031L10-20	EP036L10-20	—	—
	3	EP031L6-30	—	—	—	—	—
	4	EP031L6-40	—	—	—	—	—
3/64	1/2	EP047L6-05	—	EP047L10-05	EP052L10-05	—	—
	2	EP047L6-20	—	EP047L10-20	EP052L10-20	EP047L14-20	—
	3	—	—	EP047L10-30	—	—	—
	4	—	—	EP047L10-40	EP052L10-40	EP047L14-40	EP052L14-40
1/16	1/2	EP062L6-05	—	EP062L10-05	EP067L10-05	—	—
	2	EP062L6-20	—	EP062L10-20	EP067L10-20	EP062L14-20	—
	3	—	—	EP062L10-30	—	—	—
	4	—	—	EP062L10-40	EP067L10-40	EP062L14-40	EP067L14-40
5/64	1/2	EP078L6-05	—	EP078L10-05	EP083L10-05	—	—
	2	EP078L6-20	—	EP078L10-20	EP083L10-20	EP078L14-20	—
	3	—	—	EP078L10-30	—	—	—
	4	—	—	EP078L10-40	EP083L10-40	EP078L14-40	EP083L14-40
3/32	1/2	EP094L6-05	—	EP094L10-05	EP099L10-05	—	—
	2	EP094L6-20	—	EP094L10-20	EP099L10-20	EP094L14-20	—
	3	—	—	EP094L10-30	—	—	—
	4	—	—	EP094L10-40	EP099L10-40	EP094L14-40	EP099L14-40
7/64	1/2	EP109L6-05	—	EP109L10-05	EP114L10-05	—	—
	2	EP109L6-20	—	EP109L10-20	EP114L10-20	EP109L14-20	—
	3	—	—	EP109L10-30	—	—	—
	4	—	—	EP109L10-40	EP114L10-40	EP109L14-40	EP114L14-40

ALTERNATIVE CONFIGURATIONS AVAILABLE

- To order pins with the keys tangent to the diameter, add "-K" to the end of the catalog number. Ex. EP094L6-05-K.
- Mold-Ready Ejector Pins can be supplied cut-to-length, keyed, and/or engraved or with Black Nitride. Refer to page A-22 and procomps.com/mold-ready for more information.
- Made-to-order Pins can be quoted using the templates at procomps.com.

EJECTOR PINS

M-2: STRAIGHT-INCH STANDARD



M M-2 **H** 60-63 HRC

CAD insertion point

D NOMINAL DIAMETER	H	T	L=3"	L=6"	L=10"	L=14"	L=18"
1/32	.25	.125	EPM031L3	EPM031L6	—	—	—
3/64	.25	.125	EPM047L3	EPM047L6	—	—	—
1/16	.25	.125	EPM062L3	EPM062L6	EPM062L10	—	—
5/64	.25	.125	—	EPM078L6	—	—	—
3/32	.25	.125	EPM094L3	EPM094L6	EPM094L10	—	—
7/64	.25	.125	—	EPM109L6	—	—	—
1/8	.25	.125	EPM125L3	EPM125L6	EPM125L10	EPM125L14	—
9/64	.25	.125	—	—	EPM141L10	—	—
5/32	.28	.156	EPM156L3	EPM156L6	EPM156L10	EPM156L14	—
11/64	.34	.187	—	—	EPM172L10	—	—
3/16	.37	.187	EPM187L3	EPM187L6	EPM187L10	EPM187L14	—
13/64	.37	.187	—	—	EPM203L10	—	—
7/32	.40	.187	EPM219L3	—	EPM219L10	EPM219L14	—
1/4	.43	.187	EPM250L3	EPM250L6	EPM250L10	EPM250L14	EPM250L18
9/32	.43	.250	EPM281L3	—	EPM281L10	—	—
5/16	.50	.250	EPM312L3	EPM312L6	EPM312L10	EPM312L14	EPM312L18
11/32	.56	.250	EPM344L3	—	EPM344L10	—	—
3/8	.62	.250	EPM375L3	EPM375L6	EPM375L10	EPM375L14	EPM375L18
1/2	.75	.250	EPM500L3	—	EPM500L10	EPM500L14	—

APPLICATION GUIDELINES

- Ideal for forming contours with high surface finish requirements.
- Tolerance by head is +000/-0.001 a maximum of .25" for 3" long pins and 1" for 6" and longer pins.

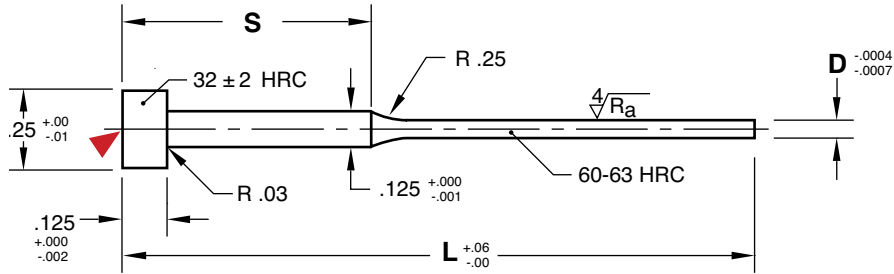
ALTERNATIVE CONFIGURATIONS AVAILABLE

- To order pins with the keys tangent to the diameter, add "-K" to the end of the catalog number. Ex. EPM250L10-K.
- Mold-Ready Ejector Pins can be supplied cut-to-length, keyed, and/or engraved or with Black Nitride. Refer to page A-22 and procomps.com/mold-ready for more information.
- Made-to-order Pins can be quoted using the templates at procomps.com.



EJECTOR PINS

M-2 SHOULDER-INCH STANDARD



M M-2 **H** 60-63 HRC ▶ CAD insertion point

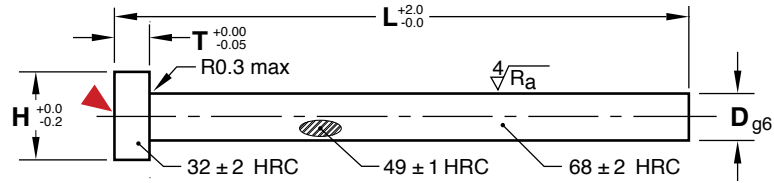
D NOMINAL DIAMETER	S SHOULDER LENGTH	L=6"	L=10"
1/32	1/2	EPM031L6-05	—
	2	EPM031L6-20	EPM031L10-20
3/64	1/2	EPM047L6-05	—
	2	EPM047L6-20	EPM047L10-20
	3	—	EPM047L10-30
1/16	1/2	EPM062L6-05	—
	2	EPM062L6-20	EPM062L10-20
	3	—	EPM062L10-30
5/64	1/2	EPM078L6-05	—
	2	EPM078L6-20	EPM078L10-20
	3	—	EPM078L10-30
3/32	1/2	EPM094L6-05	—
	2	EPM094L6-20	EPM094L10-20
	3	—	EPM094L10-30
7/64	1/2	—	EPM109L10-05
	2	—	EPM109L10-20

ALTERNATIVE CONFIGURATIONS AVAILABLE

- To order pins with the keys tangent to the diameter, add "-K" to the end of the catalog number. Ex. EPM094L6-05-K.
- Mold-Ready Ejector Pins can be supplied cut-to-length, keyed, and/or engraved or with Black Nitride. Refer to page A-22 and procomps.com/mold-ready for more information.
- Made-to-order Pins can be quoted using the templates at procomps.com.

EJECTOR PINS

THROUGH-HARD PINS: STRAIGHT-METRIC DIN STANDARD



M 1.2344 (H-13) **H** Core: 48-50 HRC, Surface: 66-70 HRC

CAD insertion point

D NOMINAL DIAMETER	H	T	L=125MM	L=160MM	L=200MM	L=250MM	L=400MM	L=630MM	L=1000MM
1.2	3	1.5	EPD012L125	EPD012L160	—	—	—	—	—
1.5	3	1.5	EPD015L125	EPD015L160	EPD015L200	EPD015L250	—	—	—
1.6	3	1.5	EPD016L125	—	EPD016L200	EPD016L250	—	—	—
1.7	3	1.5	EPD017L125	—	EPD017L200	EPD017L250	—	—	—
1.8	3	1.5	EPD018L125	—	EPD018L200	EPD018L250	—	—	—
2	4	2	EPD02L125	EPD02L160	EPD02L200	EPD02L250	EPD02L400	—	—
2.2	4	2	EPD022L125	EPD022L160	EPD022L200	EPD022L250	EPD022L400	—	—
2.5	5	2	EPD025L125	EPD025L160	EPD025L200	EPD025L250	EPD025L400	—	—
2.7	5	2	—	EPD027L160	—	EPD027L250	EPD027L400	—	—
3	6	3	EPD03L125	EPD03L160	EPD03L200	EPD03L250	EPD03L400	EPD03L630	—
3.2	6	3	EPD032L125	EPD032L160	EPD032L200	EPD032L250	EPD032L400	—	—
3.5	7	3	EPD035L125	EPD035L160	EPD035L200	EPD035L250	EPD035L400	—	—
3.7	7	3	—	EPD037L160	—	EPD037L250	EPD037L400	—	—
4	8	3	EPD04L125	EPD04L160	EPD04L200	EPD04L250	EPD04L400	EPD04L630	—
4.1	8	3	—	EPD041L160	—	EPD041L250	EPD041L400	—	—
4.2	8	3	EPD042L125	EPD042L160	EPD042L200	EPD042L250	EPD042L400	—	—
4.5	8	3	EPD045L125	EPD045L160	EPD045L200	EPD045L250	EPD045L400	—	—
4.7	8	3	EPD047L125	EPD047L160	EPD047L200	EPD047L250	EPD047L400	—	—
5	10	3	EPD05L125	EPD05L160	EPD05L200	EPD05L250	EPD05L400	EPD05L630	EPD05L1000
5.2	10	3	EPD052L125	EPD052L160	EPD052L200	EPD052L250	EPD052L400	EPD052L630	—
5.5	10	3	EPD055L125	EPD055L160	EPD055L200	EPD055L250	EPD055L400	—	—
6	12	5	EPD06L125	EPD06L160	EPD06L200	EPD06L250	EPD06L400	EPD06L630	EPD06L1000
6.1	12	5	—	EPD061L160	—	EPD061L250	EPD061L400	—	—
6.2	12	5	EPD062L125	EPD062L160	EPD062L200	EPD062L250	EPD062L400	EPD062L630	—
6.5	12	5	EPD065L125	EPD065L160	EPD065L200	EPD065L250	EPD065L400	—	—
7	12	5	EPD07L125	EPD07L160	EPD07L200	EPD07L250	EPD07L400	EPD07L630	EPD07L1000
7.5	12	5	—	EPD075L160	—	EPD075L250	EPD075L400	—	—
8	14	5	EPD08L125	EPD08L160	EPD08L200	EPD08L250	EPD08L400	EPD08L630	EPD08L1000
8.2	14	5	EPD082L125	EPD082L160	EPD082L200	EPD082L250	EPD082L400	EPD082L630	—
8.5	14	5	EPD085L125	EPD085L160	EPD085L200	EPD085L250	EPD085L400	—	—
9	14	5	EPD09L125	EPD09L160	EPD09L200	EPD09L250	EPD09L400	—	—
9.5	14	5	—	EPD095L160	—	EPD095L250	EPD095L400	—	—
10	16	5	EPD10L125	EPD10L160	EPD10L200	EPD10L250	EPD10L400	EPD10L630	EPD10L1000
10.2	16	5	EPD102L125	EPD102L160	EPD102L200	EPD102L250	EPD102L400	—	—
10.5	16	5	EPD105L125	EPD105L160	EPD105L200	EPD105L250	EPD105L400	—	—
11	16	5	EPD11L125	EPD11L160	EPD11L200	EPD11L250	EPD11L400	—	—
12	18	7	EPD12L125	EPD12L160	EPD12L200	EPD12L250	EPD12L400	EPD12L630	EPD12L1000
12.2	18	7	EPD122L125	EPD122L160	EPD122L200	EPD122L250	EPD122L400	—	—
12.5	18	7	EPD125L125	EPD125L160	EPD125L200	EPD125L250	EPD125L400	—	—
14	22	7	EPD14L125	EPD14L160	EPD14L200	EPD14L250	EPD14L400	EPD14L630	—
16	22	7	EPD16L125	EPD16L160	EPD16L200	EPD16L250	EPD16L400	EPD16L630	—
16.2	22	7	—	—	—	EPD162L250	EPD162L400	EPD162L630	—
18	24	7	—	EPD18L160	EPD18L200	EPD18L250	EPD18L400	EPD18L630	—
20	26	8	—	EPD20L160	EPD20L200	EPD20L250	EPD20L400	EPD20L630	EPD20L1000
25	32	10	—	EPD25L160	EPD25L200	EPD25L250	EPD25L400	EPD25L630	EPD25L1000
32	40	10	—	EPD32L160	EPD32L200	EPD32L250	EPD32L400	EPD32L630	EPD32L1000

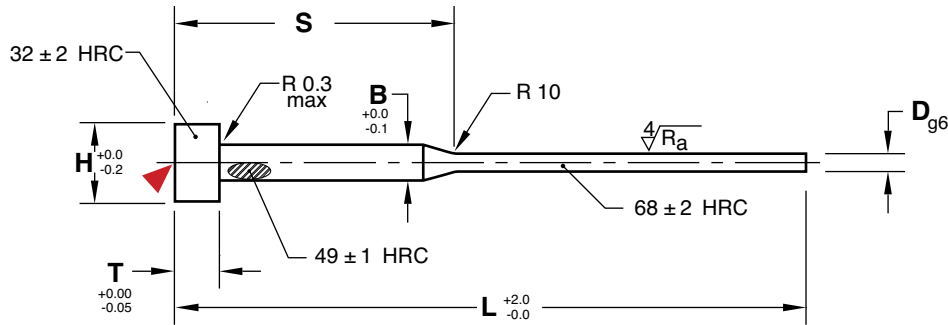
ALTERNATIVE CONFIGURATIONS AVAILABLE

- To order pins with the keys tangent to the diameter, add “-K” to the end of the catalog number. Ex. EPD06L250-K.
- Mold-Ready Ejector Pins can be supplied cut-to-length, keyed, and/or engraved or with Black Nitride. Refer to page A-22 and procomps.com/mold-ready for more information.



EJECTOR PINS

THROUGH-HARD PINS: SHOULDER-METRIC DIN STANDARD



M 1.2344 (H-13) **H** Core: 48-50 HRC, Surface: 66-70 HRC

▶ CAD insertion point

D NOMINAL DIAMETER	B	H	T	L=125MM S=50MM	L=160MM S=75MM	L=200MM S=75MM
0.8	2	4	2	EPD008X2L125-50	EPD008X2L160-75	—
0.9	2	4	2	EPD009X2L125-50	EPD009X2L160-75	—
1	2	4	2	EPD01X2L125-50	EPD01X2L160-75	EPD01X2L200-75
1.1	2	4	2	EPD011X2L125-50	EPD011X2L160-75	—
1.2	2	4	2	EPD012X2L125-50	EPD012X2L160-75	—
1.3	2	4	2	EPD013X2L125-50	EPD013X2L160-75	EPD013X2L200-75
1.4	2	4	2	EPD014X2L125-50	EPD014X2L160-75	—
1.5	3	6	3	EPD015X3L125-50	EPD015X3L160-75	EPD015X3L200-75
1.6	3	6	3	EPD016X3L125-50	EPD016X3L160-75	EPD016X3L200-75
1.7	3	6	3	—	EPD017X3L160-75	EPD017X3L200-75
1.8	3	6	3	EPD018X3L125-50	EPD018X3L160-75	EPD018X3L200-75
2	3	6	3	EPD02X3L125-50	EPD02X3L160-75	EPD02X3L200-75
2.2	3	6	3	—	EPD022X3L160-75	EPD022X3L200-75
2.5	3	6	3	EPD025X3L125-50	EPD025X3L160-75	EPD025X3L200-75

STANDARD DIN TOLERANCES

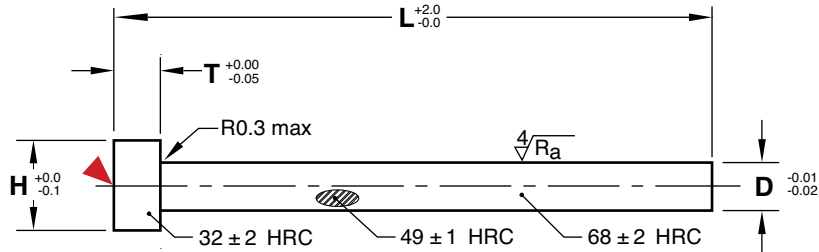
NOMINAL DIAMETER (MM)		SHAFT TOLERANCE	
Over	To	g6	
0	3	-.002	-.008
3	6	-.004	-.012
6	10	-.005	-.014
10	18	-.006	-.017
18	30	-.007	-.020
30	50	-.009	-.025

ALTERNATIVE CONFIGURATIONS AVAILABLE

- To order pins with the keys tangent to the diameter, add “-K” to the end of the catalog number. Ex. EPD018X3L125-50-K.
- Mold-Ready Ejector Pins can be supplied cut-to-length, keyed, and/or engraved or with Black Nitride. Refer to page A-22 and procomps.com/mold-ready for more information.
- Made-to-order Pins can be quoted using the templates at procomps.com.

EJECTOR PINS

THROUGH-HARD PINS: STRAIGHT-METRIC JIS STANDARD



M SKD61 (H-13) **H** Core: 48-50 HRC, Surface: 66-70 HRC

CAD insertion point

D NOMINAL DIAMETER	H	T	L= 100MM	L= 150MM	L= 200MM	L= 250MM	L= 300MM	L= 400MM	L= 500MM	L= 600MM	L= 650MM
1	4	4	EPJ01L100	EPJ01L150	EPJ01L200	—	—	—	—	—	—
1.5	4	4	EPJ015L100	EPJ015L150	EPJ015L200	EPJ015L250	—	—	—	—	—
2	5	4	EPJ02L100	EPJ02L150	EPJ02L200	EPJ02L250	—	—	—	—	—
2.5	6	4	EPJ025L100	EPJ025L150	EPJ025L200	EPJ025L250	—	—	—	—	—
3	6	4	EPJ03L100	EPJ03L150	EPJ03L200	EPJ03L250	—	—	—	—	—
3.5	7	4	EPJ035L100	EPJ035L150	EPJ035L200	EPJ035L250	—	—	—	—	—
4	8	6	—	—	EPJ04L200	EPJ04L250	EPJ04L300	EPJ04L400	—	—	—
4.5	8	6	—	—	EPJ045L200	EPJ045L250	EPJ045L300	EPJ045L400	—	—	—
5	9	6	—	—	EPJ05L200	EPJ05L250	EPJ05L300	EPJ05L400	—	—	—
5.5	10	6	—	—	EPJ055L200	EPJ055L250	EPJ055L300	EPJ055L400	—	—	—
6	10	6	—	—	EPJ06L200	EPJ06L250	EPJ06L300	EPJ06L400	EPJ06L500	—	—
7	11	6	—	—	—	EPJ07L250	EPJ07L300	EPJ07L400	EPJ07L500	—	—
8	13	8	—	—	—	—	—	EPJ08L400	EPJ08L500	EPJ08L600	—
10	15	8	—	—	—	—	—	EPJ10L400	EPJ10L500	EPJ10L600	—
12	17	8	—	—	—	—	—	—	EPJ12L500	EPJ12L600	EPJ12L650
14	19	8	—	—	—	—	—	—	EPJ14L500	—	—
15	19	8	—	—	—	—	—	—	EPJ15L500	—	—
16	21	8	—	—	—	—	—	—	EPJ16L500	—	—
18	23	8	—	—	—	—	—	—	EPJ18L500	—	—
20	25	8	—	—	—	—	—	—	EPJ20L500	—	—

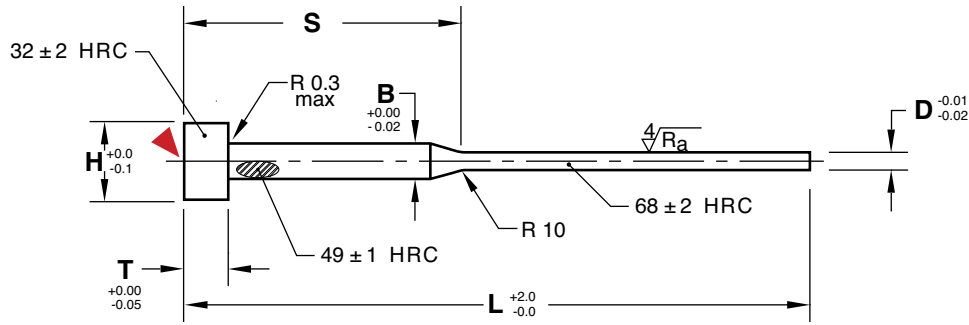
ALTERNATIVE CONFIGURATIONS AVAILABLE

- To order pins with the keys tangent to the diameter, add “-K” to the end of the catalog number. Ex. EPJ06L250-K.
- Mold-Ready Ejector Pins can be supplied cut-to-length, keyed, and/or engraved or with Black Nitride. Refer to page A-22 and procomps.com/mold-ready for more information.
- Made-to-order Pins can be quoted using the templates at procomps.com.



EJECTOR PINS

THROUGH-HARD PINS: SHOULDER-METRIC JIS STANDARD



M SKD61 (H-13) **H** Core: 48-50 HRC, Surface: 66-70 HRC

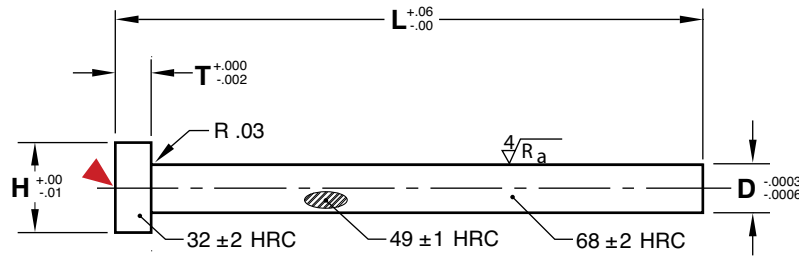
▶ CAD insertion point

D NOMINAL DIAMETER	B	H	T	L=150MM		L=200MM	
				S=50MM	S=70MM	S=70MM	S=100MM
1	2.5	5	4	EPJ01X25L150-50	—	—	EPJ01X25L200-100
	3	6	4	EPJ01X3L150-50	—	EPJ01X3L200-70	EPJ01X3L200-100
1.2	2.5	5	4	EPJ012X25L150-50	—	—	EPJ012X25L200-100
	3	6	4	EPJ012X3L150-50	—	EPJ012X3L200-70	EPJ012X3L200-100
1.5	2.5	5	4	EPJ015X25L150-50	—	—	EPJ015X25L200-100
	3	6	4	EPJ015X3L150-50	—	EPJ015X3L200-70	EPJ015X3L200-100
	4	8	6	EPJ015X4L150-50	—	—	EPJ015X4L200-100
2	3	6	4	EPJ02X3L150-50	—	EPJ02X3L200-70	EPJ02X3L200-100
	4	8	6	—	EPJ02X4L150-70	—	EPJ02X4L200-100
2.5	3	6	4	EPJ025X3L150-50	—	EPJ025X3L200-70	EPJ025X3L200-100
	4	8	6	—	EPJ025X4L150-70	—	EPJ025X4L200-100
3	4	8	6	—	EPJ03X4L150-70	—	EPJ03X4L200-100
	5	9	6	—	—	—	EPJ03X5L200-100

ALTERNATIVE CONFIGURATIONS AVAILABLE

- To order pins with the keys tangent to the diameter, add “-K” to the end of the catalog number. Ex. EPJ02X3L150-50-K.
- Mold-Ready Ejector Pins can be supplied cut-to-length, keyed, and/or engraved or with Black Nitride. Refer to page A-22 and procomps.com/mold-ready for more information.
- Made-to-order Pins can be quoted using the templates at procomps.com.

ULTRAPINS®
TREATED STRAIGHT PINS



M H-13 **H** Core: 48-50 HRC, Surface: 66-70 HRC **S** Chrome Plated: .00005-.00007" Thick

▶ CAD insertion point

NOMINAL DIAMETER	D ACTUAL PIN DIAMETER	H	T	L=6" D STANDARD	L=10" D STANDARD	L=14" D STANDARD	D ACTUAL OVERSIZED PIN DIAMETER	L=10" D .005 OVERSIZE
1/16	.0622 .0619	.25	.125	—	EPL062L10	—	—	—
5/64	.0778 .0775	.25	.125	—	EPL078L10	—	—	—
3/32	.0934 .0931	.25	.125	—	EPL094L10	—	—	—
1/8	.1247 .1244	.25	.125	EPL125L6	EPL125L10	EPL125L14	.1297 .1294	EPL130L10
5/32	.1560 .1557	.28	.156	EPL156L6	EPL156L10	—	.1610 .1607	EPL161L10
3/16	.1872 .1869	.37	.187	EPL187L6	EPL187L10	EPL187L14	.1922 .1919	EPL192L10
7/32	.2185 .2182	.40	.187	EPL219L6	EPL219L10	—	.2235 .2232	EPL224L10
1/4	.2497 .2494	.43	.187	EPL250L6	EPL250L10	EPL250L14	.2547 .2544	EPL255L10
5/16	.3122 .3119	.50	.250	EPL312L6	EPL312L10	EPL312L14	—	—
3/8	.3747 .3744	.62	.250	EPL375L6	EPL375L10	EPL375L14	—	—
7/16	.4372 .4369	.69	.250	EPL437L6	EPL437L10	EPL437L14	—	—
1/2	.4997 .4994	.75	.250	—	EPL500L10	EPL500L14	—	—

ALTERNATIVE CONFIGURATIONS AVAILABLE

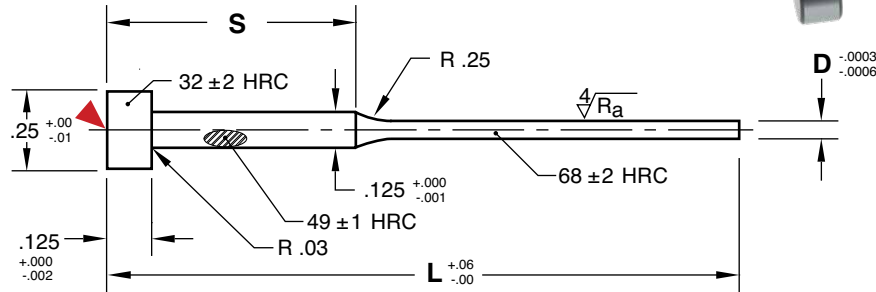
- To order pins with the keys tangent to the diameter, add “-K” to the end of the catalog number. Ex. EPL250L6-K.
- Mold-Ready UltraPins can be supplied cut-to-length, keyed, and/or engraved at a standard price and delivery. Refer to page A-22 and procomps.com/mold-ready for more information.
- Made-to-order UltraPins can be quoted using the templates at procomps.com.

APPLICATION GUIDELINES

- Maximum operating temperature: 660 °F (350 °C).
- Not recommended for Die Cast or PVC molding. Consider Black Nitrided pins shown on page A-1.



ULTRAPINS®
TREATED SHOULDER PINS



M H-13 **H** Core: 48-50 HRC, Surface: 66-70 HRC **S** Chrome Plated: .00005-.00007" Thick

▶ CAD insertion point

NOMINAL DIAMETER	D ACTUAL PIN DIAMETER	S SHOULDER LENGTH	L=6" D STANDARD	L=10" D STANDARD	D ACTUAL OVERSIZED PIN DIAMETER	L=10" D .005 OVERSIZE
1/32	.0310 .0307	1/2	EPL031L6-05	—	—	—
		2	EPL031L6-20	—	—	—
3/64	.0466 .0463	1/2	EPL047L6-05	—	.0516 .0513	EPL052L10-05
		2	EPL047L6-20	EPL047L10-20		EPL052L10-20
		3	—	EPL047L10-30	—	—
		4	—	EPL047L10-40	—	—
1/16	.0622 .0619	1/2	EPL062L6-05	—	.0672 .0669	EPL067L10-05
		2	EPL062L6-20	EPL062L10-20		EPL067L10-20
		3	—	EPL062L10-30	—	—
		4	—	EPL062L10-40	—	—
5/64	.0778 .0775	1/2	EPL078L6-05	—	.0828 .0825	EPL083L10-05
		2	EPL078L6-20	EPL078L10-20		EPL083L10-20
		3	—	EPL078L10-30	—	—
		4	—	EPL078L10-40	—	—
3/32	.0934 .0931	1/2	EPL094L6-05	—	.0985 .0982	EPL099L10-05
		2	EPL094L6-20	EPL094L10-20		EPL099L10-20
		3	—	EPL094L10-30	—	—
		4	—	EPL094L10-40	—	—
7/64	.1091 .1088	1/2	EPL109L6-05	—	.1141 .1138	EPL114L10-05
		2	EPL109L6-20	EPL109L10-20		EPL114L10-20

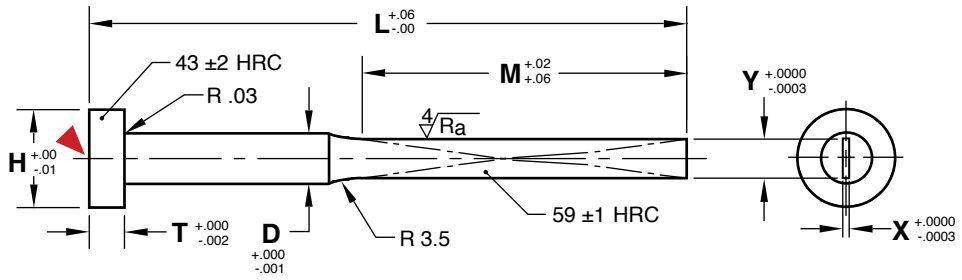
ALTERNATIVE CONFIGURATIONS AVAILABLE

- To order pins with the keys tangent to the diameter, add “-K” to the end of the catalog number. Ex. EPL094L6-05-K.
- Mold-Ready UltraPins can be supplied cut-to-length, keyed, and/or engraved at a standard price and delivery. Refer to page A-22 and procomps.com/mold-ready for more information.
- Made-to-order UltraPins can be quoted using the templates at procomps.com.

APPLICATION GUIDELINES

- Maximum operating temperature: 660°F (350°C).
- Not recommended for Die Cast or PVC molding. Consider Black Nitrided pins shown on page A-1.

BLADE EJECTORS
INCH STANDARD



M O-1 **H** 58-60 HRC

CAD insertion point

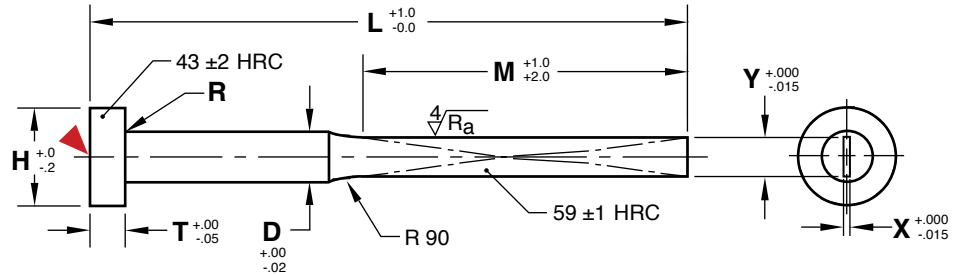
X	Y	D	H	T	L=6.5"	L=7.5"	L=10.5"
.0150	.0460	.062	.250	.125	BE062-015L6.5	BE062-015L7.5	—
.0150	.1000	.125	.250	.125	BE125-015L6.5	BE125-015L7.5	—
.0200	.0460	.062	.250	.125	BE062-020L6.5	BE062-020L7.5	—
.0200	.1000	.125	.250	.125	BE125-020L6.5	BE125-020L7.5	—
.0240	.1000	.125	.250	.125	BE125-024L6.5	BE125-024L7.5	—
.0240	.1400	.156	.281	.156	BE156-024L6.5	BE156-024L7.5	—
.0240	.1720	.187	.375	.187	BE187-024L6.5	BE187-024L7.5	—
.0320	.1000	.125	.250	.125	BE125-032L6.5	BE125-032L7.5	—
.0320	.1400	.156	.281	.156	BE156-032L6.5	BE156-032L7.5	—
.0320	.1720	.187	.375	.187	BE187-032L6.5	BE187-032L7.5	BE187-032L10.5
.0320	.2340	.250	.437	.187	BE250-032L6.5	BE250-032L7.5	BE250-032L10.5
.0320	.2960	.312	.500	.250	—	BE312-032L7.5	BE312-032L10.5
.0320	.3590	.375	.625	.250	—	BE375-032L7.5	BE375-032L10.5
.0460	.1000	.125	.250	.125	BE125-046L6.5	BE125-046L7.5	—
.0460	.1400	.156	.281	.156	BE156-046L6.5	BE156-046L7.5	—
.0460	.1720	.187	.375	.187	BE187-046L6.5	BE187-046L7.5	BE187-046L10.5
.0460	.2340	.250	.437	.187	BE250-046L6.5	BE250-046L7.5	BE250-046L10.5
.0460	.2960	.312	.500	.250	—	BE312-046L7.5	BE312-046L10.5
.0460	.3590	.375	.625	.250	—	BE375-046L7.5	BE375-046L10.5
.0620	.1720	.187	.375	.187	BE187-062L6.5	BE187-062L7.5	BE187-062L10.5
.0620	.2340	.250	.437	.187	BE250-062L6.5	BE250-062L7.5	BE250-062L10.5
.0620	.2960	.312	.500	.250	—	BE312-062L7.5	BE312-062L10.5
.0620	.3590	.375	.625	.250	—	BE375-062L7.5	BE375-062L10.5
.0780	.2960	.312	.500	.250	—	BE312-078L7.5	BE312-078L10.5
.0780	.3590	.375	.625	.250	—	BE375-078L7.5	BE375-078L10.5
.0780	.4840	.500	.750	.250	—	BE500-078L7.5	BE500-078L10.5
.0780	.5470	.562	.812	.250	—	BE562-078L7.5	BE562-078L10.5
.0780	.6090	.625	.875	.250	—	BE625-078L7.5	BE625-078L10.5
.0940	.4220	.437	.687	.250	—	BE437-094L7.5	BE437-094L10.5
.0940	.4840	.500	.750	.250	—	BE500-094L7.5	BE500-094L10.5
.0940	.5470	.562	.812	.250	—	BE562-094L7.5	BE562-094L10.5
.0940	.6090	.625	.875	.250	—	BE625-094L7.5	BE625-094L10.5
Blade Length M					M=5"	M=5"	M=6"

ALTERNATIVE CONFIGURATIONS AVAILABLE

- To order Blade Ejectors with the keys tangent to the diameter, add "-K" to the end of the catalog number. Ex. BE500-094L7.5-K.
- Mold-Ready Blades can be supplied cut-to-length, keyed, and/or engraved at a standard price and delivery. Refer to page A-22 and procomps.com/mold-ready for more information.



BLADE EJECTORS METRIC DIN STANDARD



M 1.2510 (O-1) **H** 58-60 HRC

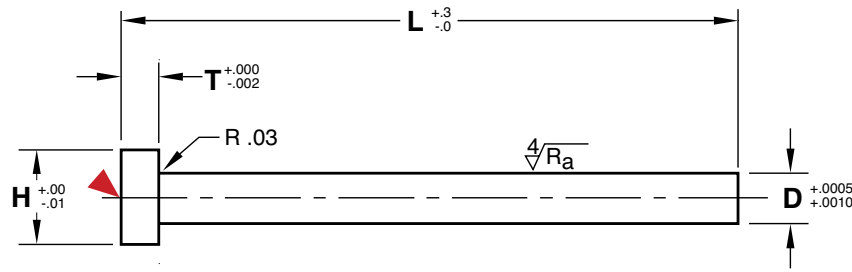
▶ CAD insertion point

X	Y	D	H	T	R	L= 60MM	L= 80MM	L= 100MM	L= 125MM	L= 160MM	L= 200MM	L= 250MM	L= 315MM	L= 400MM
1.0	3.5	4	8	3	0.3	BE4-1.0L60	BE4-1.0L80	BE4-1.0L100	BE4-1.0L125	BE4-1.0L160	—	—	—	—
1.2	3.5	4	8	3	0.3	—	BE4-1.2L80	BE4-1.2L100	BE4-1.2L125	BE4-1.2L160	—	—	—	—
1.5	4.5	5	10	3	0.3	—	BE5-1.5L80	BE5-1.5L100	BE5-1.5L125	BE5-1.5L160	—	—	—	—
1.2	5.5	6	12	5	0.5	—	BE6-1.2L80	BE6-1.2L100	BE6-1.2L125	BE6-1.2L160	BE6-1.2L200	—	—	—
1.5	5.5	6	12	5	0.5	—	BE6-1.5L80	BE6-1.5L100	BE6-1.5L125	BE6-1.5L160	BE6-1.5L200	—	—	—
2.0	5.5	6	12	5	0.5	—	BE6-2.0L80	BE6-2.0L100	BE6-2.0L125	BE6-2.0L160	BE6-2.0L200	—	—	—
1.2	7.5	8	14	5	0.5	—	—	BE8-1.2L100	BE8-1.2L125	BE8-1.2L160	BE8-1.2L200	BE8-1.2L250	—	—
1.5	7.5	8	14	5	0.5	—	—	BE8-1.5L100	BE8-1.5L125	BE8-1.5L160	BE8-1.5L200	BE8-1.5L250	—	—
2.0	7.5	8	14	5	0.5	—	—	BE8-2.0L100	BE8-2.0L125	BE8-2.0L160	BE8-2.0L200	BE8-2.0L250	BE8-2.0L315	—
1.5	9.5	10	16	5	0.5	—	—	—	—	BE10-1.5L160	BE10-1.5L200	BE10-1.5L250	BE10-1.5L315	—
2.0	9.5	10	16	5	0.5	—	—	—	—	BE10-2.0L160	BE10-2.0L200	BE10-2.0L250	BE10-2.0L315	BE10-2.0L400
2.0	11.5	12	20	7	0.8	—	—	—	—	—	BE12-2.0L200	BE12-2.0L250	BE12-2.0L315	BE12-2.0L400
2.5	11.5	12	20	7	0.8	—	—	—	—	—	BE12-2.5L200	BE12-2.5L250	BE12-2.5L315	BE12-2.5L400
2.0	15.5	16	22	7	0.8	—	—	—	—	—	BE16-2.0L200	BE16-2.0L250	BE16-2.0L315	BE16-2.0L400
2.5	15.5	16	22	7	0.8	—	—	—	—	—	BE16-2.5L200	BE16-2.5L250	BE16-2.5L315	BE16-2.5L400
Blade Length M						M= 30MM	M= 40MM	M= 50MM	M= 60MM	M= 80MM	M= 100MM	M= 125MM	M= 160MM	M= 200MM

ALTERNATIVE CONFIGURATIONS AVAILABLE

- To order Blade Ejectors with the keys tangent to the diameter, add “-K” to the end of the catalog number. Ex. BE4-1.2L80-K.
- Mold-Ready Blades can be supplied cut-to-length, keyed, and/or engraved at a standard price and delivery. Refer to page A-22 and procomps.com/mold-ready for more information.
- Made-to-order Blade Ejectors can be quoted using the templates at procomps.com.

CORE PINS



M H-13 **H** 30-35 HRC

D NOMINAL DIA.	H	T	L=3"	L=6"	L=10"	L=14"
3/32	.25	.125	CPS094L3	CPS094L6	CPS094L10	—
7/64	.25	.125	CPS109L3	CPS109L6	CPS109L10	—
1/8	.25	.125	CPS125L3	CPS125L6	CPS125L10	CPS125L14
9/64	.25	.125	CPS141L3	CPS141L6	CPS141L10	CPS141L14
5/32	.28	.156	CPS156L3	CPS156L6	CPS156L10	CPS156L14
11/64	.34	.187	CPS172L3	CPS172L6	CPS172L10	CPS172L14
3/16	.37	.187	CPS187L3	CPS187L6	CPS187L10	CPS187L14
13/64	.37	.187	CPS203L3	CPS203L6	CPS203L10	CPS203L14
7/32	.40	.187	CPS219L3	CPS219L6	CPS219L10	CPS219L14
15/64	.40	.187	—	CPS234L6	CPS234L10	—
1/4	.43	.187	CPS250L3	CPS250L6	CPS250L10	CPS250L14
9/32	.43	.250	CPS281L3	CPS281L6	CPS281L10	CPS281L14
5/16	.50	.250	CPS312L3	CPS312L6	CPS312L10	CPS312L14
11/32	.56	.250	CPS344L3	CPS344L6	CPS344L10	CPS344L14
3/8	.62	.250	CPS375L3	CPS375L6	CPS375L10	CPS375L14
13/32	.68	.250	CPS406L3	CPS406L6	CPS406L10	CPS406L14
7/16	.68	.250	CPS437L3	CPS437L6	CPS437L10	CPS437L14
15/32	.75	.250	CPS469L3	CPS469L6	CPS469L10	CPS469L14
1/2	.75	.250	CPS500L3	CPS500L6	CPS500L10	CPS500L14
17/32	.75	.250	—	CPS531L6	CPS531L10	—
9/16	.81	.250	—	CPS562L6	CPS562L10	CPS562L14
5/8	.87	.250	—	CPS625L6	CPS625L10	CPS625L14
11/16	.93	.250	—	CPS687L6	CPS687L10	CPS687L14
3/4	1.00	.250	—	CPS750L6	CPS750L10	CPS750L14
13/16	1.125	.250	—	CPS812L6	CPS812L10	CPS812L14
7/8	1.125	.250	—	CPS875L6	CPS875L10	CPS875L14
1	1.25	.250	—	CPS1000L6	CPS1000L10	CPS1000L14

M H-13 **H** 50-55 HRC

▶ CAD insertion point

D NOMINAL DIA.	H	T	L=3"	L=6"	L=10"	L=14"
3/32	.25	.125	CPH094L3	CPH094L6	CPH094L10	—
7/64	.25	.125	CPH109L3	CPH109L6	CPH109L10	—
1/8	.25	.125	CPH125L3	CPH125L6	CPH125L10	CPH125L14
9/64	.25	.125	CPH141L3	CPH141L6	CPH141L10	CPH141L14
5/32	.28	.156	CPH156L3	CPH156L6	CPH156L10	CPH156L14
11/64	.34	.187	CPH172L3	CPH172L6	CPH172L10	CPH172L14
3/16	.37	.187	CPH187L3	CPH187L6	CPH187L10	CPH187L14
13/64	.37	.187	CPH203L3	CPH203L6	CPH203L10	CPH203L14
7/32	.40	.187	CPH219L3	CPH219L6	CPH219L10	CPH219L14
15/64	.40	.187	—	CPH234L6	CPH234L10	—
1/4	.43	.187	CPH250L3	CPH250L6	CPH250L10	CPH250L14
9/32	.43	.250	CPH281L3	CPH281L6	CPH281L10	CPH281L14
5/16	.50	.250	CPH312L3	CPH312L6	CPH312L10	CPH312L14
11/32	.56	.250	CPH344L3	CPH344L6	CPH344L10	CPH344L14
3/8	.62	.250	CPH375L3	CPH375L6	CPH375L10	CPH375L14
13/32	.68	.250	CPH406L3	CPH406L6	CPH406L10	CPH406L14
7/16	.68	.250	CPH437L3	CPH437L6	CPH437L10	CPH437L14
15/32	.75	.250	CPH469L3	CPH469L6	CPH469L10	CPH469L14
1/2	.75	.250	CPH500L3	CPH500L6	CPH500L10	CPH500L14
17/32	.75	.250	—	CPH531L6	CPH531L10	—
9/16	.81	.250	—	CPH562L6	CPH562L10	CPH562L14
5/8	.87	.250	—	CPH625L6	CPH625L10	CPH625L14
11/16	.93	.250	—	CPH687L6	CPH687L10	CPH687L14
3/4	1.00	.250	—	CPH750L6	CPH750L10	CPH750L14
13/16	1.125	.250	—	CPH812L6	CPH812L10	CPH812L14
7/8	1.125	.250	—	CPH875L6	CPH875L10	CPH875L14
1	1.25	.250	—	CPH1000L6	CPH1000L10	CPH1000L14

APPLICATION GUIDELINES

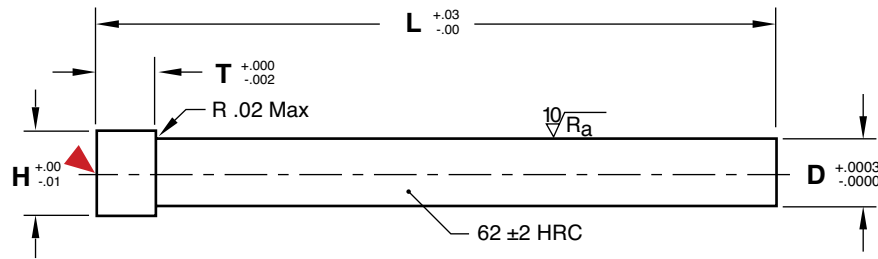
- Heads are annealed on 6", 10", and 14" lengths on the high hardness (CPH) pins.
- Core Pin diameter tolerance is +.000/-.001 for a 1" distance from the head.

ALTERNATIVE CONFIGURATIONS AVAILABLE

- Made-to-order Core Pins can be quoted using the templates at procomps.com.



TI™ PINS
THOUSANDTH INCREMENT PINS



M M-2 **H** 60-64 HRC

CAD insertion point

D DECIMAL PIN DIAMETER	H HEAD DIAMETER	T HEAD THICKNESS	L=2.5"	L=5.5"
.060 - .062	.093	.125	TI*L2.5	TI*L5.5
.0625	.093	.125	TI0625L2.5	TI0625L5.5
.063 - .093	.156	.125	TI*L2.5	TI*L5.5
.0937	.156	.125	TI0937L2.5	TI0937L5.5
.094 - .124	.187	.125	TI*L2.5	TI*L5.5
.1250	.187	.125	TI1250L2.5	TI1250L5.5
.126 - .156	.218	.125	TI*L2.5	TI*L5.5
.1562	.218	.125	TI1562L2.5	TI1562L5.5
.157 - .187	.250	.125	TI*L2.5	TI*L5.5
.1875	.250	.125	TI1875L2.5	TI1875L5.5
.188 - .218	.281	.125	TI*L2.5	TI*L5.5
.2187	.281	.125	TI2187L2.5	TI2187L5.5
.219 - .249	.312	.125	TI*L2.5	TI*L5.5
.2500	.312	.125	TI2500L2.5	TI2500L5.5
.251 - .312	.437	.187	TI*L2.5	TI*L5.5
.3125	.437	.187	TI3125L2.5	TI3125L5.5
.313 - .320	.500	.187	TI*L2.5	TI*L5.5

To Order:

Specify the prefix of "TI", then the diameter, followed by the length.

- Follow three place diameters with a "0".
- Nominal fractional sizes are carried to a four-place decimal as listed in the chart.

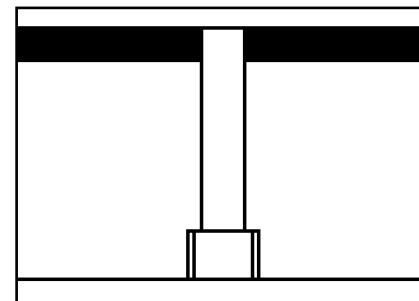
Examples: TI0900L2.5 or TI2520L5.5 or for nominal sizes: TI2500L2.5 or TI3125L5.5

APPLICATION GUIDELINES

- TI Pins allow for the use of wire EDM to the finish diameter, with no step machining required for a core pin.
- Unlike punches, TI Pin heads are precision ground to standard mold tolerances.

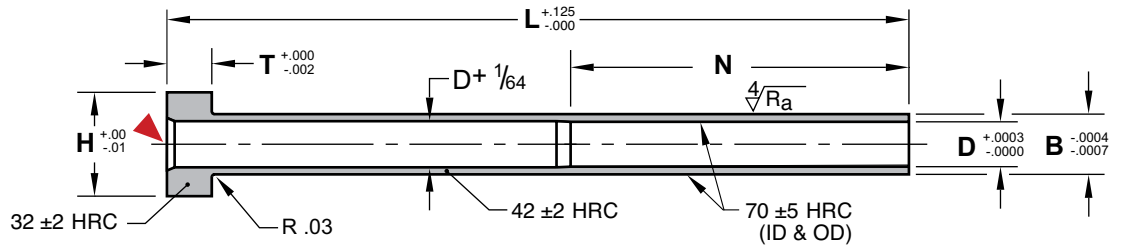
ALTERNATIVE CONFIGURATIONS AVAILABLE

- Made-to-order TI Pins can be quoted using the templates at procomps.com.



EJECTOR SLEEVES

INCH STANDARD



General Dimensions:
 N=1-7/8" for ES094 & ES125 T=.187" for ES094 thru ES156
 N=2-3/8" for ES156 and larger T=.250" for ES187 and larger

M H-13 **H** Core: 40-44 HRC, Surface: 65-75 HRC

▶ CAD insertion point

D NOM. I.D.	B O.D.	H	L=3"	L=4"	L=5"	L=6"	L=7"	L=8"	L=9"	L=10"	L=11"	L=12"	L=13"	L=14"
3/32	.1875	.37	ES094L3	ES094L4	ES094L5	ES094L6	ES094L7	ES094L8	ES094L9	ES094L10	ES094L11	—	—	—
1/8	.2187	.40	ES125L3	ES125L4	ES125L5	ES125L6	ES125L7	ES125L8	ES125L9	ES125L10	ES125L11	—	—	—
5/32	.2500	.43	—	ES156L4	ES156L5	ES156L6	ES156L7	ES156L8	ES156L9	ES156L10	ES156L11	ES156L12	ES156L13	ES156L14
3/16	.3125	.50	—	ES187L4	ES187L5	ES187L6	ES187L7	ES187L8	ES187L9	ES187L10	ES187L11	ES187L12	ES187L13	ES187L14
7/32	.3437	.56	—	ES219L4	ES219L5	ES219L6	ES219L7	ES219L8	ES219L9	ES219L10	ES219L11	ES219L12	ES219L13	ES219L14
1/4	.3750	.62	—	ES250L4	ES250L5	ES250L6	ES250L7	ES250L8	ES250L9	ES250L10	ES250L11	ES250L12	ES250L13	ES250L14
5/16	.4375	.68	—	ES312L4	ES312L5	ES312L6	ES312L7	ES312L8	ES312L9	ES312L10	ES312L11	ES312L12	ES312L13	ES312L14
3/8	.5000	.75	—	ES375L4	ES375L5	ES375L6	ES375L7	ES375L8	ES375L9	ES375L10	ES375L11	ES375L12	ES375L13	ES375L14
7/16	.6250	.87	—	ES437L4	ES437L5	ES437L6	ES437L7	ES437L8	ES437L9	ES437L10	ES437L11	ES437L12	ES437L13	ES437L14
1/2	.6875	.93	—	ES500L4	ES500L5	ES500L6	ES500L7	ES500L8	ES500L9	ES500L10	ES500L11	ES500L12	ES500L13	ES500L14
9/16	.7500	1.00	—	ES562L4	ES562L5	ES562L6	ES562L7	ES562L8	ES562L9	ES562L10	ES562L11	ES562L12	ES562L13	ES562L14
5/8	.8750	1.12	—	ES625L4	ES625L5	ES625L6	ES625L7	ES625L8	ES625L9	ES625L10	ES625L11	ES625L12	ES625L13	ES625L14
3/4	1.0000	1.25	—	ES750L4	ES750L5	ES750L6	ES750L7	ES750L8	ES750L9	ES750L10	ES750L11	ES750L12	ES750L13	ES750L14

INCH STANDARD-EXTRA LENGTH SERIES

M H-13 **H** Core: 40-44 HRC, Surface: 65-75 HRC

D NOM. I.D.	B O.D.	H	L=15"	L=16"	L=17"	L=18"
5/32	.2500	.43	ES156L15	ES156L16	ES156L17	ES156L18
3/16	.3125	.50	ES187L15	ES187L16	ES187L17	ES187L18
7/32	.3437	.56	ES219L15	ES219L16	ES219L17	ES219L18
1/4	.3750	.62	ES250L15	ES250L16	ES250L17	ES250L18
5/16	.4375	.68	ES312L15	ES312L16	ES312L17	ES312L18
3/8	.5000	.75	ES375L15	ES375L16	ES375L17	ES375L18
7/16	.6250	.87	ES437L15	ES437L16	ES437L17	ES437L18
1/2	.6875	.93	ES500L15	ES500L16	ES500L17	ES500L18
9/16	.7500	1.00	ES562L15	ES562L16	ES562L17	ES562L18
5/8	.8750	1.12	ES625L15	ES625L16	ES625L17	ES625L18
3/4	1.0000	1.25	ES750L15	ES750L16	ES750L17	ES750L18

General Dimensions:
 N=2-3/8" for ES156 T=.187" for ES156
 N=2-3/4" for ES187 thru ES219 T=.250" for ES187 and larger
 N=3-1/4" for ES250 and larger

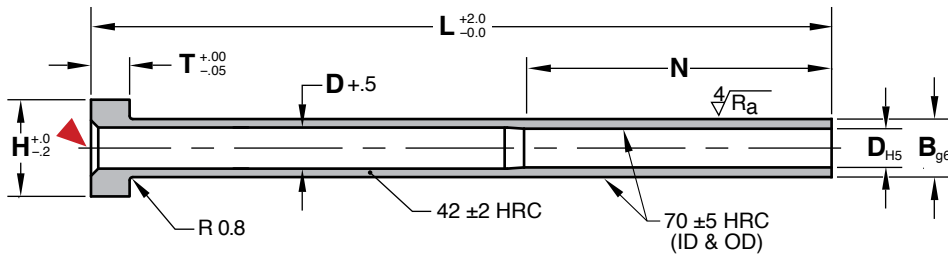
ALTERNATIVE CONFIGURATIONS AVAILABLE

- For sleeves that are .005" oversized on the outer diameter (B), add "-OS" to the end of the part number. Ex. ES250L12-OS.
- Sleeves can be ordered with the Black Nitride treatment for better performance. To order, specify "-BN" at the end of the catalog number. Ex. ES437L7-BN.
- To achieve longer lengths, use Sleeve Extensions shown on page A-19.
- Mold-Ready Sleeves can be supplied cut-to-length, keyed, and/or engraved at a standard price and delivery. Refer to page A-22 and procomps.com/mold-ready for more information.
- Made-to-order Sleeves can be quoted using the templates at procomps.com.



EJECTOR SLEEVES

METRIC DIN STANDARD



General Dimensions:

N=35mm for ESD015 thru ESD025	T=3mm for ESD015 thru ESD032
N=45mm for ESD027 thru ESD10	T=5mm for ESD035 thru ESD062
N=55mm for ESD102 and larger	T=7mm for ESD08 thru ESD125
	T=9mm for ESD14 and larger

M H-13 **H** Core: 40-44 HRC, Surface: 65-75 HRC

▶ CAD insertion point

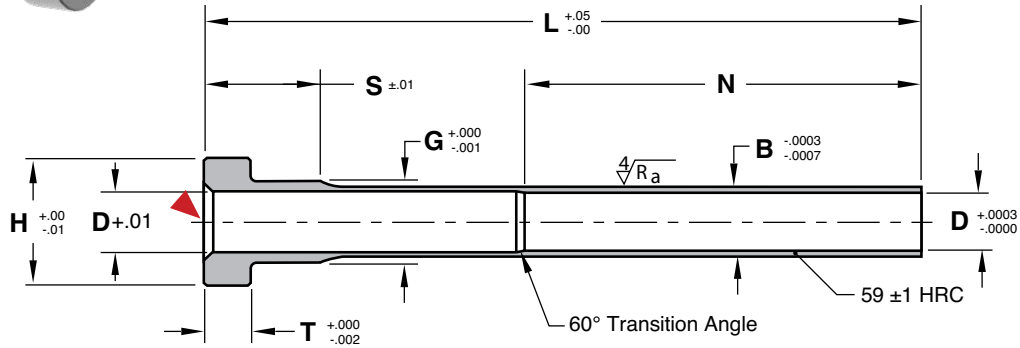
CATALOG NUMBER	D	B	H	LENGTHS (L)												
				75MM	100MM	125MM	150MM	175MM	200MM	225MM	250MM	275MM	300MM	325MM	350MM	400MM
ESD015	1.5	3	6		•	•	•									
ESD016	1.6	3	6		•	•	•									
ESD02	2	4	8		•	•	•	•	•							
ESD022	2.2	4	8	•	•	•	•	•								
ESD025	2.5	5	10	•	•	•	•	•		•						
ESD027	2.7	5	10	•	•	•	•	•		•						
ESD03	3	5	10	•	•	•	•	•	•	•	•	•	•	•	•	•
ESD032	3.2	5	10	•	•	•	•	•	•							
ESD035	3.5	6	12	•	•	•	•	•		•						
ESD037	3.7	6	12	•	•	•	•	•	•	•	•					
ESD04	4	6	12	•	•	•	•	•	•	•	•	•				
ESD042	4.2	8	14	•	•	•	•	•	•							
ESD05	5	8	14	•	•	•	•	•	•	•	•	•	•	•	•	•
ESD052	5.2	8	14	•	•	•	•	•	•	•	•	•	•	•	•	•
ESD055	5.5	8	14	•	•	•	•	•	•	•	•					
ESD06	6	10	16	•	•	•	•	•	•	•	•	•	•	•	•	•
ESD062	6.2	10	16	•	•	•	•	•	•	•	•	•	•	•	•	•
ESD08	8	12	20	•	•	•	•	•	•	•	•	•	•	•	•	•
ESD082	8.2	12	20	•	•	•	•	•	•	•	•	•	•	•	•	•
ESD10	10	14	22	•	•	•	•	•	•	•	•					
ESD102	10.2	14	22	•	•	•	•	•	•	•	•					
ESD105	10.5	14	22		•	•	•	•	•	•						
ESD12	12	16	22		•	•	•	•	•	•	•					
ESD125	12.5	16	22		•	•	•	•	•	•						
ESD14	14	18	24		•	•	•	•	•	•	•	•	•	•	•	•
ESD16	16	20	26		•	•	•	•	•	•	•	•	•	•	•	•
ESD18	18	22	28		•	•	•	•	•	•	•	•	•	•	•	•

To Order: Specify the ESD prefix with the inner diameter (D), and length. Ex. ESD035L175.

<p>ALTERNATIVE CONFIGURATIONS AVAILABLE</p>	<ul style="list-style-type: none"> Sleeves can be ordered with the Black Nitride treatment for better performance. To order, specify "-BN" at the end of the catalog number. Ex. ESD08L250-BN. To achieve longer lengths, use Sleeve Extensions on page A-19. Mold-Ready Sleeves can be supplied cut-to-length, keyed, and/or engraved at a standard price and delivery. Refer to page A-22 and procomps.com/mold-ready for more information. Made-to-order Sleeves can be quoted using the templates at procomps.com.
--	---

EJECTOR SLEEVES

THIN WALL SERIES



M A-2 **H** 58-60 HRC **M** Electroless Nickel PTFE Coated

CAD insertion point

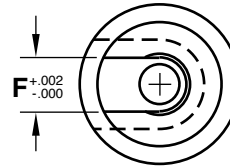
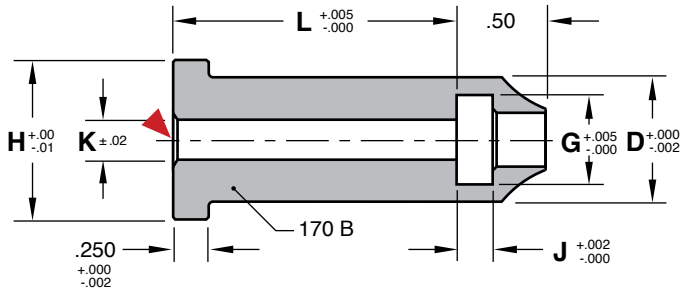
D NOMINAL I.D.	D DECIMAL I.D.	B O.D.	G	S	H	T	N	L=4"	L=6"	L=8"	L=10"
3/32	.0937	.1563	.188	.500	.37	.187	1.75	ESTW094L4	ESTW094L6	—	—
1/8	.1250	.1875	.219	.500	.40	.187	1.75	ESTW125L4	ESTW125L6	ESTW125L8	—
5/32	.1562	.2187	.250	.500	.43	.187	2.50	ESTW156L4	ESTW156L6	ESTW156L8	ESTW156L10
3/16	.1875	.2500	.312	.625	.50	.250	2.50	ESTW187L4	ESTW187L6	ESTW187L8	ESTW187L10
7/32	.2187	.2813	.344	.625	.56	.250	2.50	ESTW219L4	ESTW219L6	ESTW219L8	ESTW219L10
1/4	.2500	.3125	.375	.625	.62	.250	2.50	ESTW250L4	ESTW250L6	ESTW250L8	ESTW250L10
5/16	.3125	.3750	.438	.625	.68	.250	2.50	ESTW312L4	ESTW312L6	ESTW312L8	ESTW312L10
3/8	.3750	.4375	.500	.625	.75	.250	2.50	ESTW375L4	ESTW375L6	ESTW375L8	ESTW375L10

ALTERNATIVE CONFIGURATIONS AVAILABLE

- To achieve longer lengths, use Sleeve Extensions on page A-19.
- Mold-Ready Sleeves can be supplied cut-to-length, keyed, and/or engraved at a standard price and delivery. Refer to page A-22 and procomps.com/mold-ready for more information.
- Made-to-order Sleeves can be quoted using the templates at procomps.com.



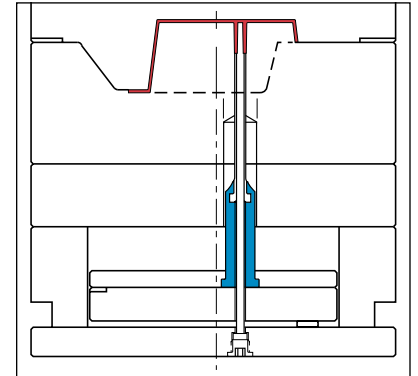
SLEEVE EXTENSIONS



M AISI 1215 **H** 170 Brinell **S** Black Oxide

CAD insertion point

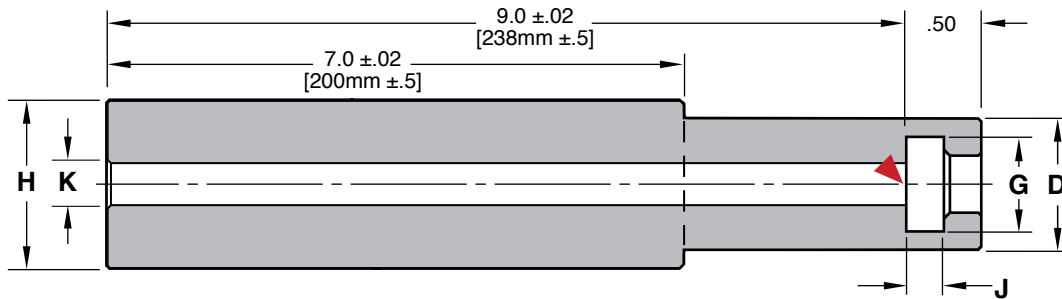
NOMINAL SLEEVE I.D.	D O.D.	F	G	H	J	K	L=2"	L=3"	L=4"
3/32	.625	.193	.385	.875	.188	.18	SXT094L2	SXT094L3	—
1/8	.625	.224	.416	.875	.188	.18	SXT125L2	SXT125L3	SXT125L4
5/32	.625	.255	.448	.875	.188	.18	SXT156L2	SXT156L3	SXT156L4
3/16	.875	.318	.520	1.125	.251	.21	SXT187L2	SXT187L3	SXT187L4
7/32	.875	.349	.570	1.125	.251	.25	SXT219L2	SXT219L3	SXT219L4
1/4	.875	.380	.630	1.125	.251	.28	SXT250L2	SXT250L3	SXT250L4
5/16	1.000	.443	.698	1.250	.251	.34	SXT312L2	SXT312L3	SXT312L4
3/8	1.000	.505	.760	1.250	.251	.41	SXT375L2	SXT375L3	SXT375L4



SLEEVE EXTENSIONS: BLANKS

APPLICATION GUIDELINES

- For extending a Sleeve, begin with a Sleeve Extension Blank and lathe turn the "H" dimension to a standard Ejector Pin head size.



Inch Standard

M AISI 1215 **H** 170 Brinell

CATALOG NUMBER	NOMINAL SLEEVE I.D.	D O.D.	F +.002 - .000	G +.005 - .000	H +.00 - .01	J +.002 - .000	K ±.02
SXT094-B	3/32	.625	.193	.385	.875	.188	.18
SXT125-B	1/8	.625	.224	.416	.875	.188	.18
SXT156-B	5/32	.625	.255	.448	.875	.188	.18
SXT187-B	3/16	.875	.318	.520	1.125	.251	.21
SXT219-B	7/32	.875	.349	.570	1.125	.251	.25
SXT250-B	1/4	.875	.380	.630	1.125	.251	.28
SXT312-B	5/16	1.000	.443	.698	1.250	.251	.34
SXT375-B	3/8	1.000	.505	.760	1.250	.251	.41

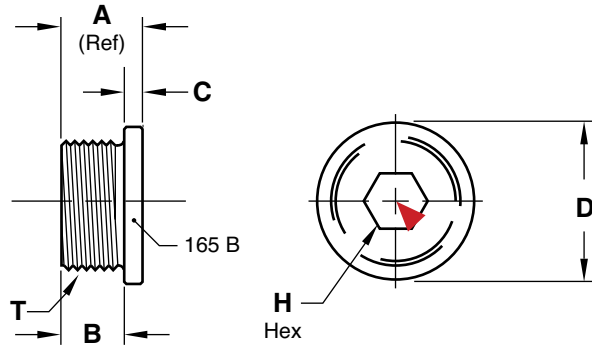
Metric Standard

M AISI 1215 **H** 170 Brinell

CAD insertion point

CATALOG NUMBER	NOMINAL SLEEVE I.D.	D O.D.	F +.05 - .00	G +.01 - .00	H +.0 - .2	J +.05 - .00	K ±.2
SXTD02-B	2 - 2.2	14	4.15	8.3	22	3.03	4
SXTD03-B	2.5 - 3.2	16	5.15	10.3	22	3.03	4
SXTD05-B	3.5 - 5.5	20	8.15	14.3	26	5.03	6
SXTD06-B	6 - 6.2	22	10.15	16.3	28	5.03	7
SXTD08-B	8 - 8.2	25	12.15	20.3	32	7.03	9
SXTD10-B	10 - 12.5	32	16.15	22.3	40	7.03	13

CORE PIN RETAINERS



Inch Standard

M AISI 12L14 **H** 165 Brinell **S** Black Oxide ▶ CAD insertion point

CATALOG NUMBER	A	B +.001 -.000	C +.000 -.002	D +.00 -.01	H	T
CPR-50	.437	.312	.125	.750	.25	1/2-20
CPR-87	.437	.312	.125	1.060	.37	7/8-14

Metric Standard

M AISI 12L14 **H** 165 Brinell **S** Black Oxide

CATALOG NUMBER	A	B +.02 -.00	C +.00 -.05	D +.0 -.2	H	T
CPRM-16	11	7	4	20	8	M16-1.5
CPRM-20	11	7	4	26	10	M20-2.5

CPR-50

CPR-87

CPRM-16

CPRM-20

CORE PIN DIAMETER	H
3/32 - 9/64	.563
5/32	.594
11/64 - 1/4	.625
9/32	.688

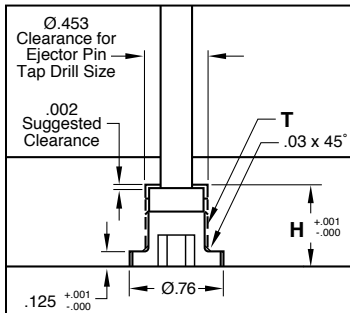
CORE PIN DIAMETER	H
5/16 - 1/2	.688

CORE PIN DIAMETER (DIN)	H
1.2 - 2.7mm	13.02mm
3 - 5.5mm	14.02mm
6 - 7.5mm	16.02mm

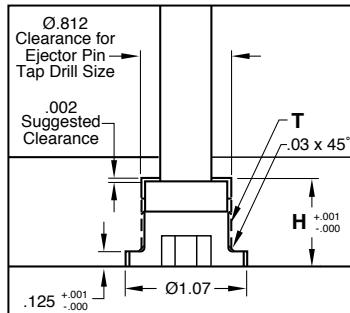
CORE PIN DIAMETER (DIN)	H
8 - 11mm	16.02mm
12 - 12.5mm	18.02mm

Machining Specifications:

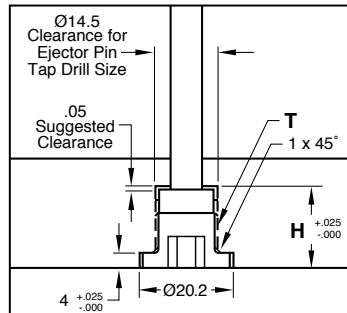
CPR-50



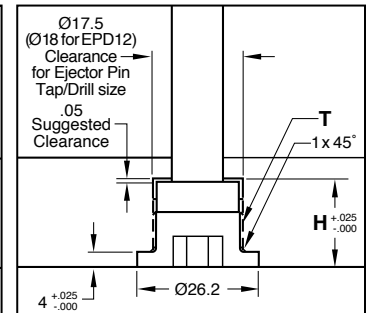
CPR-87



CPRM-16

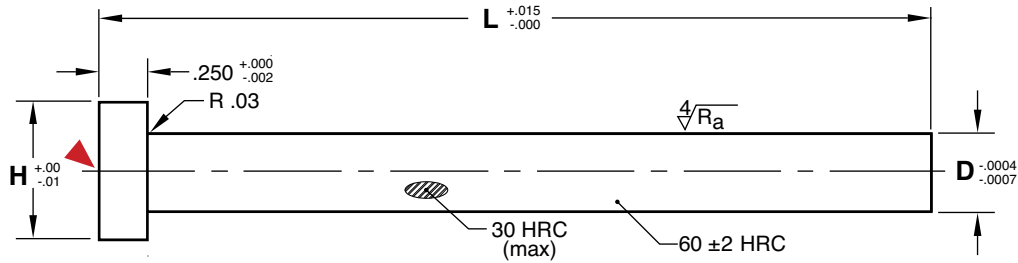


CPRM-20





RETURN PINS



M AISI 52100 **H** Core: 30 HRC Max, Surface: 58-62 HRC

▶ CAD insertion point

D=1/2 H=3/4		D=5/8 H=7/8		D=3/4 H=1		D=1 H=1-1/4	
L	CATALOG NUMBER	L	CATALOG NUMBER	L	CATALOG NUMBER	L	CATALOG NUMBER
3-9/16	RP50L3.56	4-1/16	RP62L4.06	4-15/16	RP75L4.93	—	—
4-1/16	RP50L4.06	4-9/16	RP62L4.56	5-7/16	RP75L5.43	—	—
4-9/16	RP50L4.56	5-1/16	RP62L5.06	5-15/16	RP75L5.93	—	—
5-1/16	RP50L5.06	5-9/16	RP62L5.56	6-7/16	RP75L6.43	6	RP100L6
5-9/16	RP50L5.56	6-1/16	RP62L6.06	6-15/16	RP75L6.93	—	—
6-1/16	RP50L6.06	6-9/16	RP62L6.56	7-7/16	RP75L7.43	—	—
6-9/16	RP50L6.56	7-1/16	RP62L7.06	7-15/16	RP75L7.93	—	—
—	—	7-9/16	RP62L7.56	8-7/16	RP75L8.43	—	—
—	—	8-1/16	RP62L8.06	8-15/16	RP75L8.93	—	—
—	—	—	—	9-7/16	RP75L9.43	10	RP100L10
—	—	—	—	—	—	18	RP100L18

ALTERNATIVE CONFIGURATIONS AVAILABLE

- Made-to-order Return Pins can be quoted using the templates at procomps.com.

APPLICATION GUIDELINES

- Return Pins are designed to be drilled and tapped on either end.

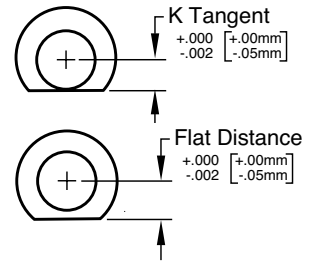
MOLD-READY™ KEYED PINS, SLEEVES, & BLADES

To order Pins, Sleeves, or Blades with the flat machined on the head tangent to the diameter, designate "-K" on the end of the catalog number.

To order Pins, Sleeves, or Blades with the flat machined on the head at a specific distance from the center of the pin, specify the catalog number and the specific distance after the "-K" designation for the flat.

Examples:

- EP437L10-K for a standard Ejector Pin with a key ground tangent.
- EPM437L10-K.250 for an M-2 Ejector Pin with a flat 1/4" from center.
- CPH125L6-K.094 for a standard Core Pin with a flat ground 3/32" from center.
- ES562L5-K for a standard Sleeve with a key ground tangent.
- BE125-O46L6.5-K.094 for an Ejector Blade with the flat 3/32" from center.

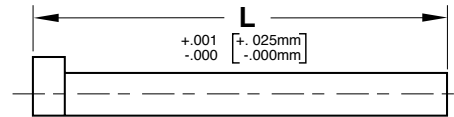
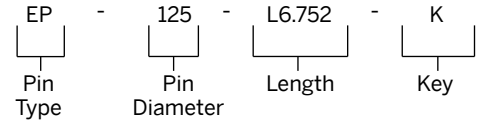


MOLD-READY™ CUT-TO-LENGTH PINS, SLEEVES, & BLADES

To order Pins, Sleeves, or Blades cut to your specified length, +.001/-.000 (+.025/-.000mm), with or without keyed heads, specify the length required after the standard catalog numbers.

Examples:

- EP125L6.752-K for a finished length Ejector Pin with a key ground tangent.
- EPM437L6.25-K.250 for a finished length M-2 Ejector Pin with a flat 1/4" from center.
- ES562L5.75 is a for a finished length Ejector Sleeve.
- BE125-O46L4.250-K for a finished length Ejector Blade with a key ground tangent.



ADDITIONAL SERVICES PROVIDED

- Detail or model numbers up to 4 digits can be laser engraved on the heads of Pins, Sleeves, and Blades.
- Black Nitride can be applied on Ejector Pins larger than 1/16" (1.6mm) diameter and Sleeves. To order, specify "-BN" at the end of the catalog number. Note: Black Nitride can add up to .0001" on diameters.
- For a quote, send your request to customerservice@procomps.com.

MADE-TO-ORDER CUSTOM PINS & SLEEVES

Progressive can provide custom, finished pins per print, template, or CAD model. For a quote, send your request to tech@procomps.com.

Templates are also available online at procomps.com.





MOLD BASE COMPONENTS

SECTION B



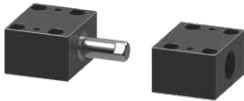
Sprue Bushings	Locating Rings	Extended Sprues	Puller Pins & Bushings	PKO Extensions
Prefix: SPR	Prefix: LR	Prefix: ESB, RX	Prefix: PP, PPB	Prefix: PH, PKP
Page: B-1	Page: B-2 & B-3	Page: B-4 & B-5	Page: B-6	Page: B-7



Leader Pins: Inch	Leader Pins: DIN	Guided Ejector Pins	Leader Pins: Shoulder	Leader Pins: Nitride
Prefix: LP	Prefix: LPD	Prefix: GEP, LP	Prefix: SLP	Prefix: LP Suffix: -BN
Page: B-8	Page: B-9	Page: B-10	Page: B-11	Page: B-12



Bushings: Black Nitride	Bushings: Shoulder	Bushings: Straight	Guided Ej. Bushings	Front Load Pins & Bush.
Prefix: STL, GEB (-BN)	Prefix: SAB, SHB, SGP	Prefix: STB, STGP	Prefix: GEB, GGP, GQC	Prefix: FLPB
Page: B-13	Page: B-14 & B-15	Page: B-15	Page: B-16 & B-17	Page: B-18



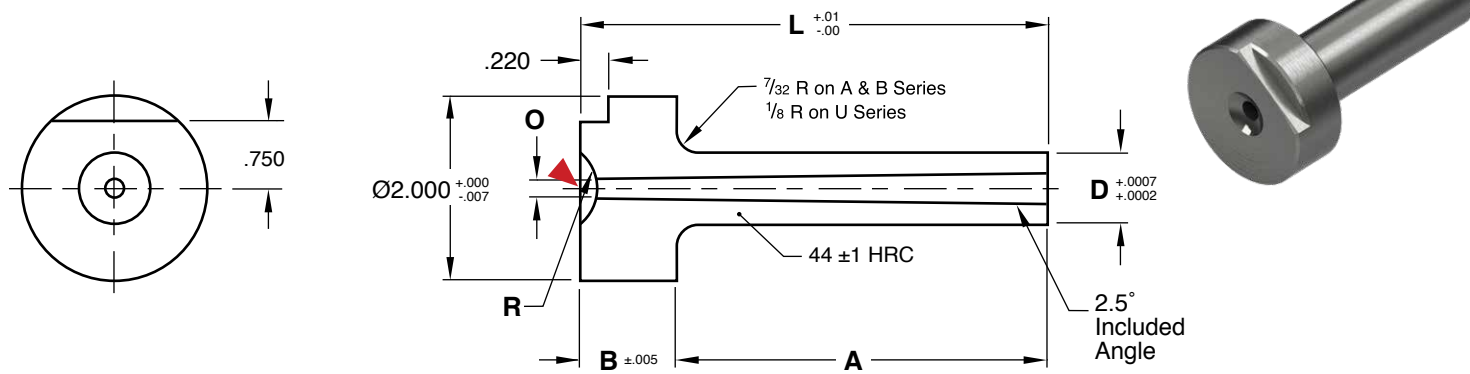
Guide Blocks	Support Pillars	Guided Support Pillars	Urethane Springs	Springs
Prefix: GBK	Prefix: SP, SPH	Prefix: GESP	Prefix: US	Prefix: MS, HS
Page: B-19	Page: B-20 - B-22	Page: B-23	Page: B-24	Page: B-25 - B-27



Stripper Bolts/Bushings	Tubular Dowels	Stop Discs & Pins	Spacers	Safety Straps
Prefix: SBLT, SBB	Prefix: TD	Prefix: SD, STP	Prefix: SPC	Prefix: SAFT
Page: B-28 & B-29	Page: B-30	Page: B-31	Page: B-31	Page: B-32



SPRUE BUSHINGS



B Series **D=Ø1.000** **B=.875**

M AISI 6150 **H** 43-45 HRC

A	L	O=5/32		O=7/32		O=9/32		O=11/32		NO HOLE	
		R=1/2	R=3/4	R=1/2	R=3/4	R=1/2	R=3/4	R=1/2	R=3/4	R=1/2	R=3/4
29/32	1-25/32	SPRB1-512	SPRB1-534	SPRB1-712	SPRB1-734	SPRB1-912	SPRB1-934	SPRB1-112	SPRB1-134	—	—
1-13/32	2-9/32	SPRB2-512	SPRB2-534	SPRB2-712	SPRB2-734	SPRB2-912	SPRB2-934	SPRB2-112	SPRB2-134	—	—
1-29/32	2-25/32	SPRB3-512	SPRB3-534	SPRB3-712	SPRB3-734	SPRB3-912	SPRB3-934	SPRB3-112	SPRB3-134	—	—
2-13/32	3-9/32	SPRB4-512	SPRB4-534	SPRB4-712	SPRB4-734	SPRB4-912	SPRB4-934	SPRB4-112	SPRB4-134	—	—
2-29/32	3-25/32	SPRB5-512	SPRB5-534	SPRB5-712	SPRB5-734	SPRB5-912	SPRB5-934	SPRB5-112	SPRB5-134	SPRB5-N12	SPRB5-N34
3-13/32	4-9/32	SPRB6-512	SPRB6-534	SPRB6-712	SPRB6-734	SPRB6-912	SPRB6-934	SPRB6-112	SPRB6-134	—	—
3-29/32	4-25/32	SPRB7-512	SPRB7-534	SPRB7-712	SPRB7-734	SPRB7-912	SPRB7-934	SPRB7-112	SPRB7-134	—	—
4-13/32	5-9/32	SPRB8-512	SPRB8-534	SPRB8-712	SPRB8-734	SPRB8-912	SPRB8-934	SPRB8-112	SPRB8-134	—	—
4-29/32	5-25/32	SPRB9-512	SPRB9-534	SPRB9-712	SPRB9-734	SPRB9-912	SPRB9-934	SPRB9-112	SPRB9-134	SPRB9-N12	SPRB9-N34
5-29/32	6-25/32	—	—	SPRB10-712	SPRB10-734	SPRB10-912	SPRB10-934	—	—	—	—
6-29/32	7-25/32	—	—	SPRB11-712	SPRB11-734	SPRB11-912	SPRB11-934	SPRB11-112	SPRB11-134	SPRB11-N12	SPRB11-N34

▶ CAD insertion point

A Series **D=Ø1.000** **B=.625**

A	L	O=5/32		O=7/32		O=9/32		O=11/32		NO HOLE	
		R=1/2	R=3/4	R=1/2	R=3/4	R=1/2	R=3/4	R=1/2	R=3/4	R=1/2	R=3/4
1-3/16	1-13/16	SPRA1-512	SPRA1-534	SPRA1-712	SPRA1-734	SPRA1-912	SPRA1-934	SPRA1-112	SPRA1-134	—	—
1-11/16	2-5/16	SPRA2-512	SPRA2-534	SPRA2-712	SPRA2-734	SPRA2-912	SPRA2-934	SPRA2-112	SPRA2-134	—	—
2-3/16	2-13/16	SPRA3-512	SPRA3-534	SPRA3-712	SPRA3-734	SPRA3-912	SPRA3-934	SPRA3-112	SPRA3-134	SPRA3-N12	SPRA3-N34
2-11/16	3-5/16	SPRA4-512	SPRA4-534	SPRA4-712	SPRA4-734	SPRA4-912	SPRA4-934	SPRA4-112	SPRA4-134	—	—
3-3/16	3-13/16	SPRA5-512	SPRA5-534	SPRA5-712	SPRA5-734	SPRA5-912	SPRA5-934	SPRA5-112	SPRA5-134	—	—
3-11/16	4-5/16	SPRA6-512	SPRA6-534	SPRA6-712	SPRA6-734	SPRA6-912	SPRA6-934	SPRA6-112	SPRA6-134	—	—
4-3/16	4-13/16	SPRA7-512	SPRA7-534	SPRA7-712	SPRA7-734	SPRA7-912	SPRA7-934	SPRA7-112	SPRA7-134	SPRA7-N12	SPRA7-N34

U Series **D=Ø.750** **B=.875**

A	L	O=5/32		O=7/32		O=9/32		NO HOLE	
		R=1/2	R=3/4	R=1/2	R=3/4	R=1/2	R=3/4	R=1/2	R=3/4
29/32	1-25/32	SPRU1-512	SPRU1-534	SPRU1-712	SPRU1-734	SPRU1-912	SPRU1-934	—	—
1-13/32	2-9/32	SPRU2-512	SPRU2-534	SPRU2-712	SPRU2-734	SPRU2-912	SPRU2-934	—	—
1-29/32	2-25/32	SPRU3-512	SPRU3-534	SPRU3-712	SPRU3-734	SPRU3-912	SPRU3-934	SPRU3-N12	SPRU3-N34
2-13/32	3-9/32	SPRU4-512	SPRU4-534	SPRU4-712	SPRU4-734	SPRU4-912	SPRU4-934	—	—
2-29/32	3-25/32	SPRU5-512	SPRU5-534	SPRU5-712	SPRU5-734	SPRU5-912	SPRU5-934	SPRU5-N12	SPRU5-N34

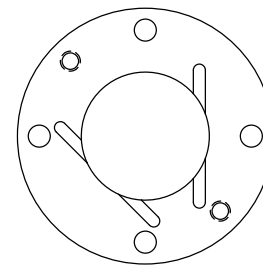
For Hot Sprue Bushings, refer to page K-8.

LOCATING RINGS



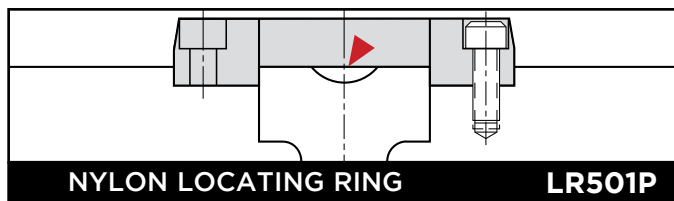
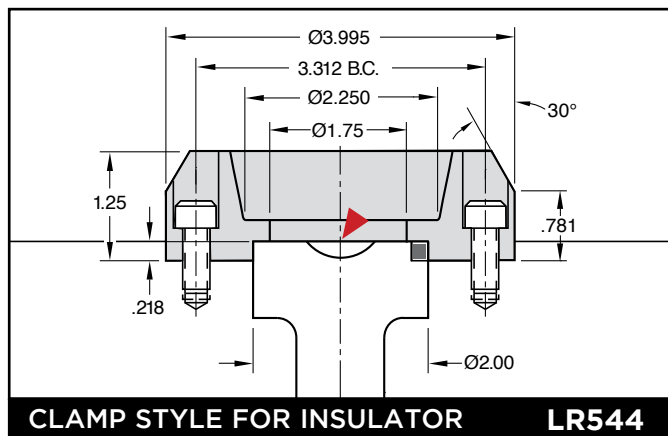
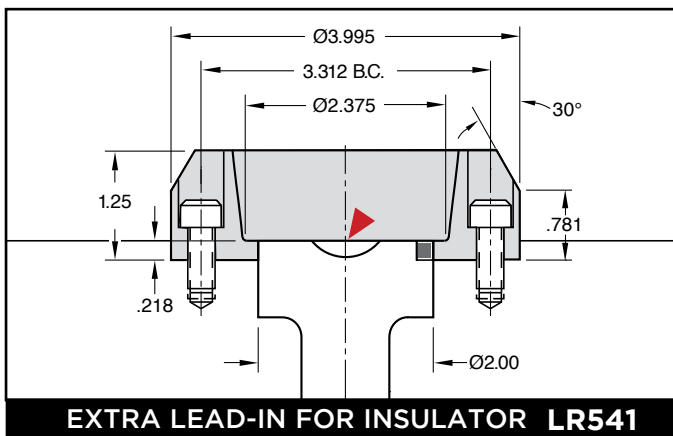
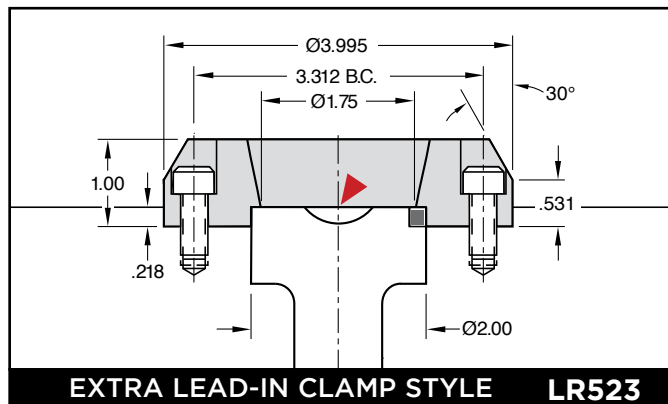
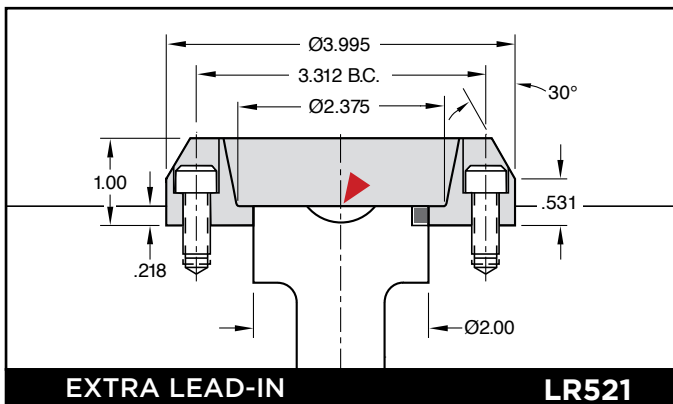
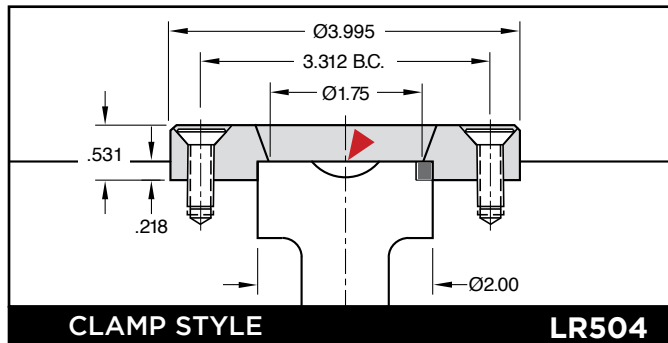
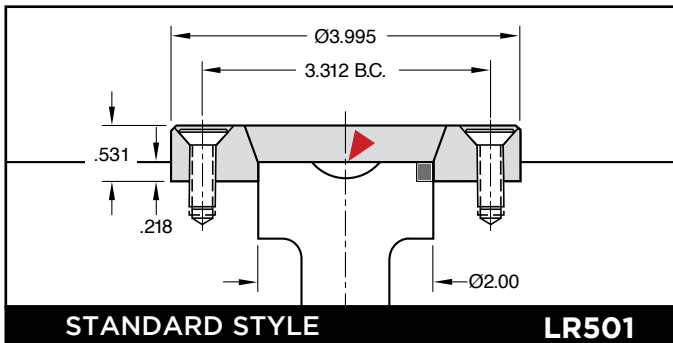
APPLICATION GUIDELINES

- Enlarged and tapered inner diameters allow for easier material removal.
- The four screw holes on each, plus the angled key slots, allow for installation every 45° as shown in the graphic at right.
- Jack out threads help with removal.
- 5/16-18 screws (2) and 3/16 diameter x 2" long dowel pin included.



M AISI 1018 **H** 126 Brinell **S** Black Oxide

▶ CAD insertion point



- Material: 100% recycled reinforced Nylon
- Maximum temperature: 380°F (190°C)
- Compatible with LR501.
- 5/16-18 screws (2) included.



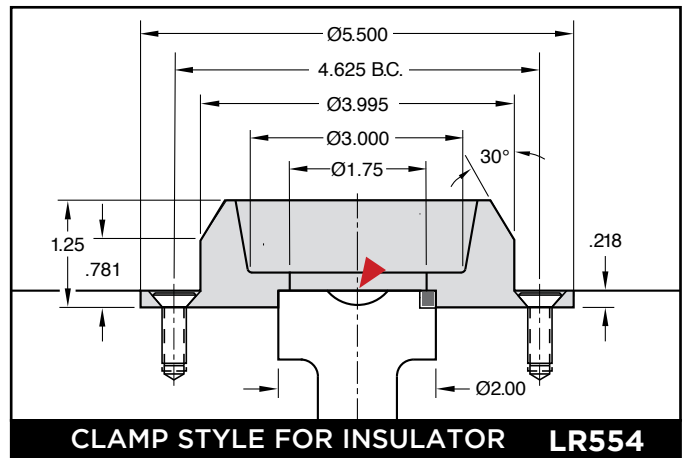
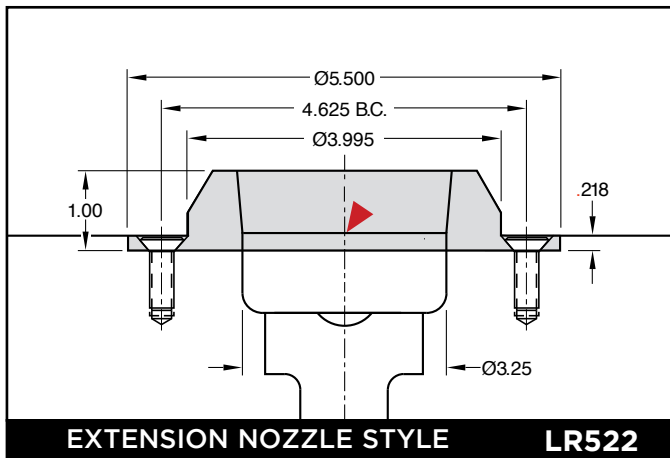
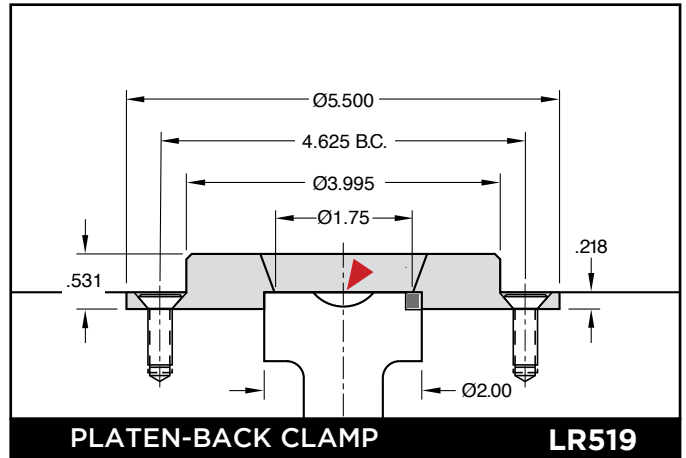
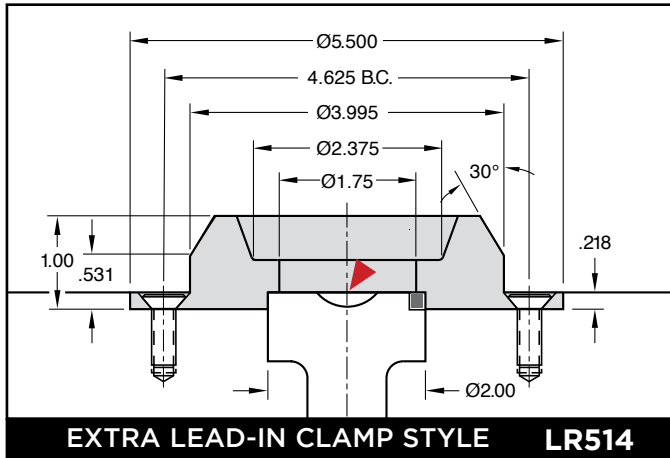
LOCATING RINGS FLANGE SERIES



APPLICATION GUIDELINES

- Enlarged and tapered inner diameters allow for easier material removal.
- The four screw holes on each, plus the angled key slots, allow for installation every 45° as shown in the graphic on the opposite page.
- Jack out threads help with removal.
- 5/16-18 screws (2) and 3/16 diameter x 2" long dowel pin included.

M AISI 1018 **H** 170 Brinell **S** Black Oxide



SHIMS



APPLICATION GUIDELINES

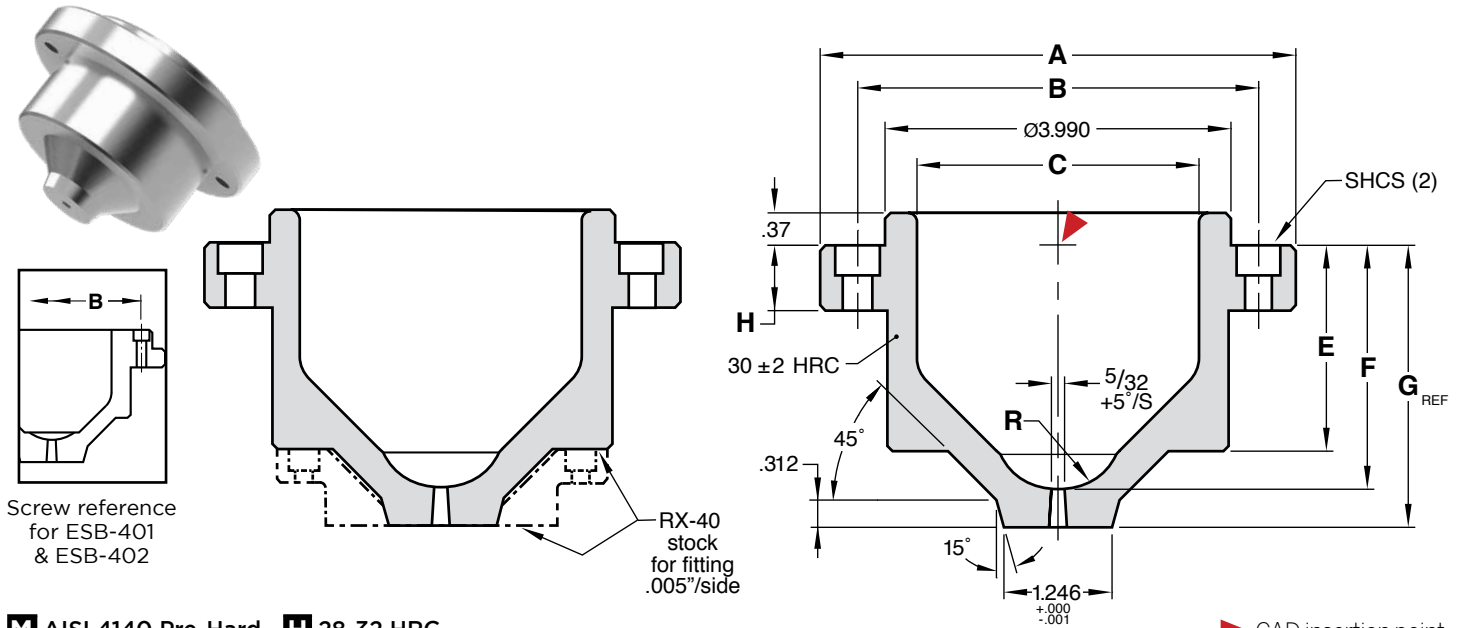
- Shims allow for pre-loading the flanged Locating Rings to compensate for a worn or dished platen as well as compensate for high injection pressures in the center of the mold.
- Three thicknesses are available to enable preload for the center of the mold.
- Sold individually to accommodate stacking requirements.
- Sized with screw clearances to match flanged Locating Rings.

M 316 Stainless Steel

CATALOG NUMBER	THICKNESS
LRS-02	.002"
LRS-03	.003"
LRS-05	.005"

EXTENDED SPRUE BUSHINGS

RX FLUSH STYLE



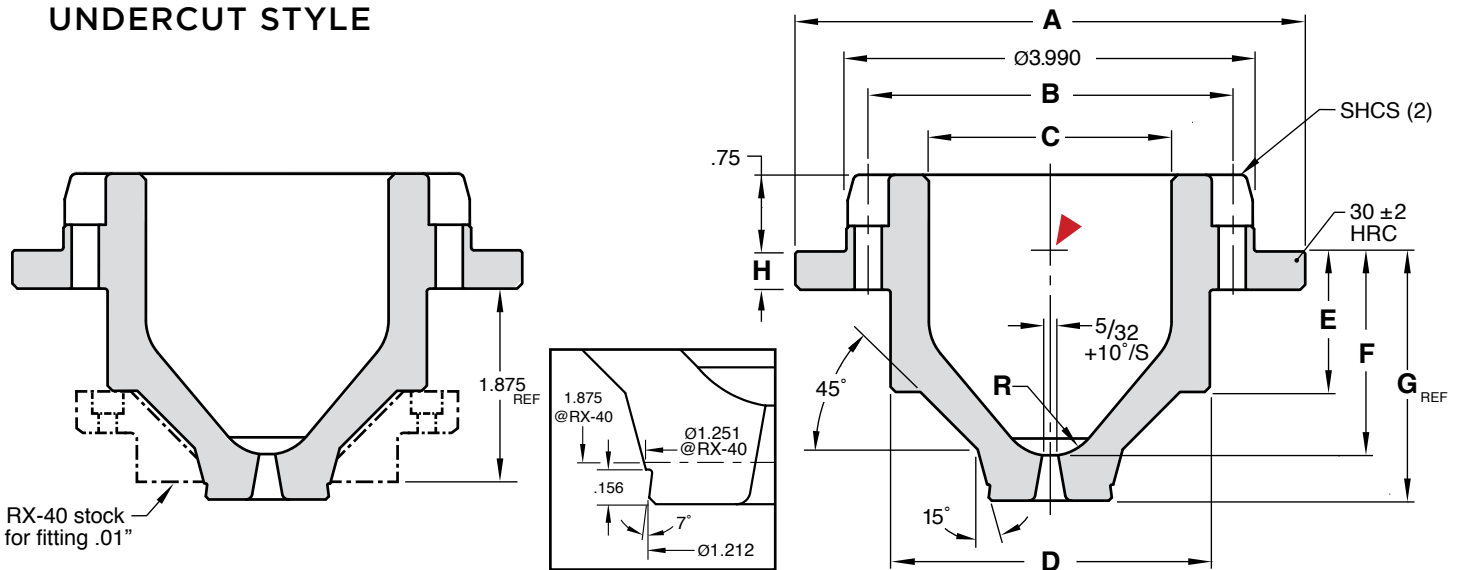
M AISI 4140 Pre-Hard **H** 28-32 HRC

▶ CAD insertion point

CATALOG NUMBER	A	B	C	D	E	F	G	H	R	SHCS
ESB-401	4.490	3.562	2.37	3.12	1.37	1.87	2.256	.375	1/2	#10-32 x 7/8
ESB-402	4.490	3.562	2.37	3.12	1.37	1.81	2.256	.375	3/4	#10-32 x 7/8
ESB-551	5.490	4.625	3.25	3.93	1.87	2.37	2.756	.750	1/2	5/16-18 x 1
ESB-552	5.490	4.625	3.25	3.93	1.87	2.31	2.756	.750	3/4	5/16-18 x 1
ESB-551L	5.490	4.625	3.25	3.93	2.37	2.87	3.256	.750	1/2	5/16-18 x 1
ESB-552L	5.490	4.625	3.25	3.93	2.37	2.81	3.256	.750	3/4	5/16-18 x 1

Screws included.

UNDERCUT STYLE



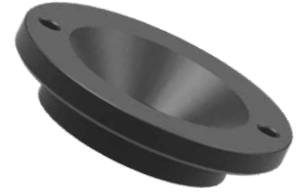
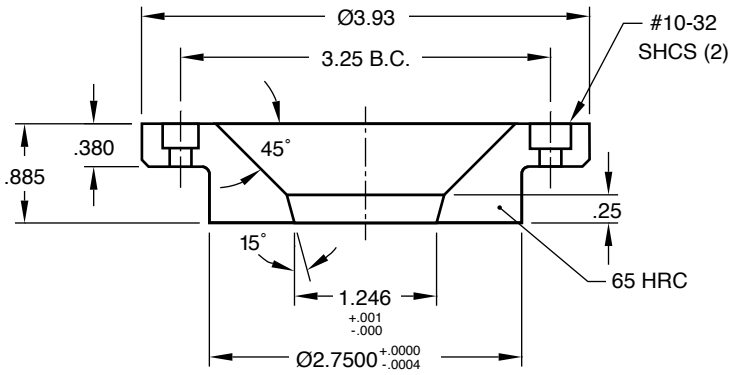
M AISI 4140 Pre-Hard **H** 28-32 HRC

CATALOG NUMBER	A	B	C	D	E	F	G	H	R	SHCS
ESB-501	4.990	3.563	2.37	3.12	1.37	2.00	2.438	.375	1/2	1/4-20 x 1

Screws included.



RUNNER STRIPPER PLATE BUSHING

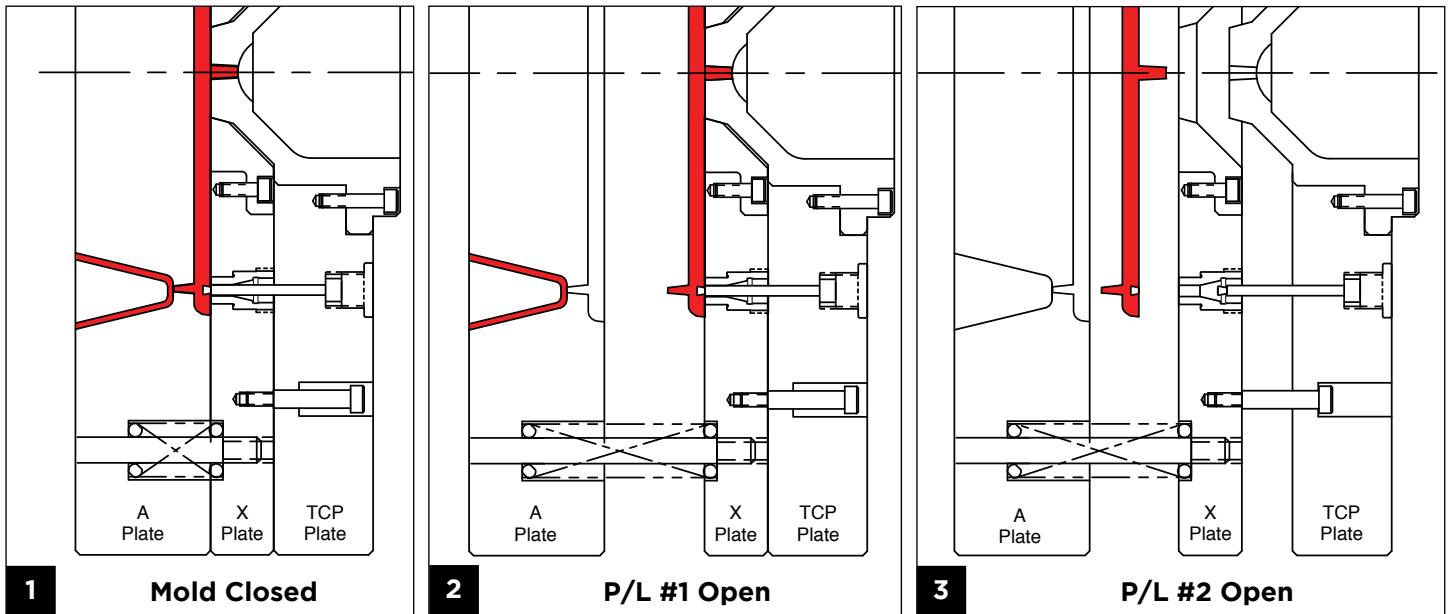


M AISI 4140 Pre-Hard **S** Black Nitride
H Core: 28-32 HRC, Surface: 65 HRC

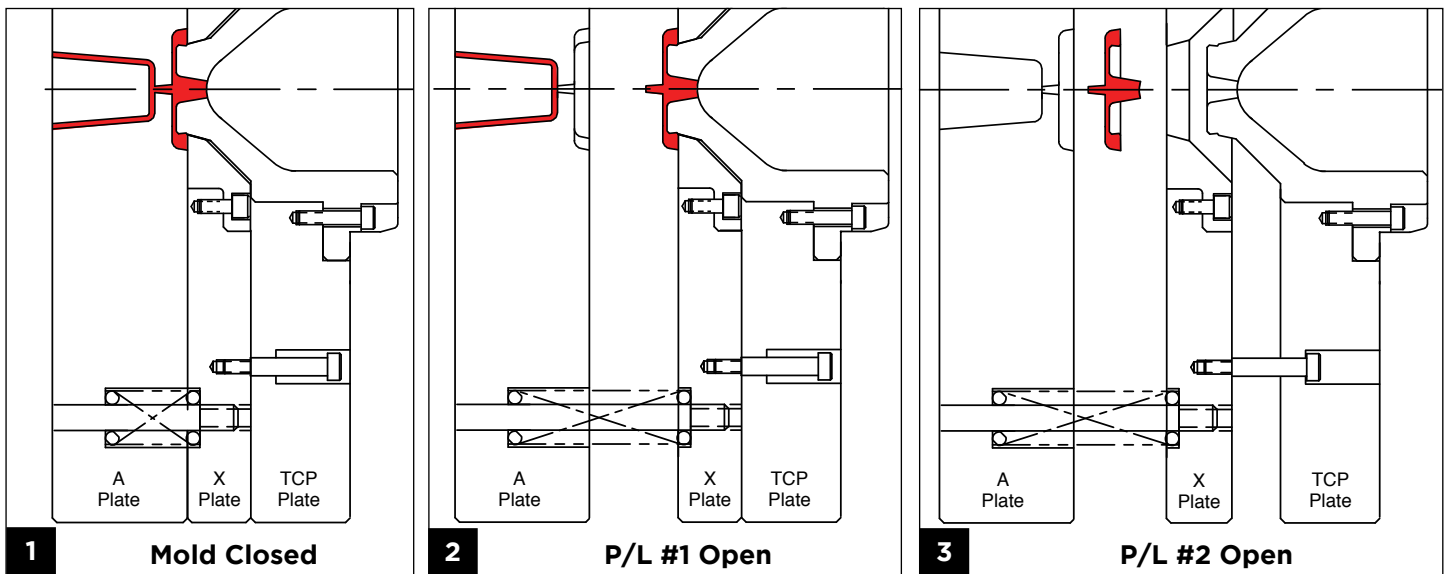
CATALOG NUMBER	DESCRIPTION
RX-40	Runner Stripper Plate Bushing

Screws included.

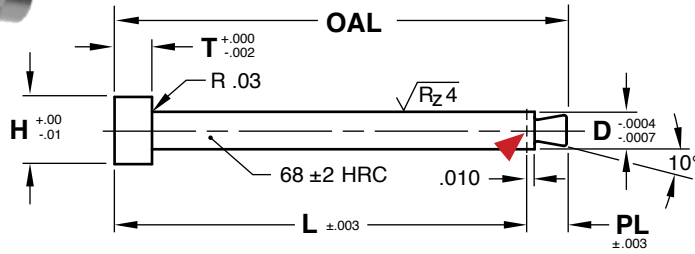
RX Flush Style Extended Sprue & Stripper Plate Bushing Application



Undercut Style Extended Sprue & Stripper Plate Bushing Application



PULLER PINS™
FOR 3-PLATE RUNNERS



Pin Length Selection Chart

G PLATE THICKNESS	L FOR 7/8" PLATE	L FOR 1-3/8" PLATE
1-3/8	1.813	2.313
1-7/8	2.313	2.813
2-3/8	2.813	3.313

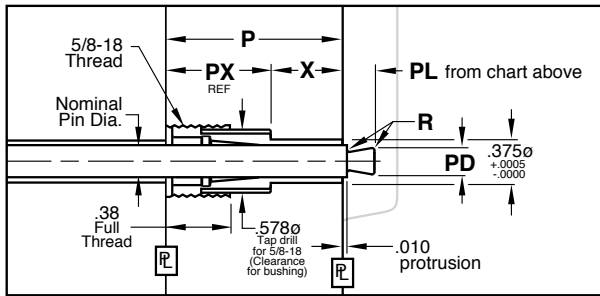
M H-13 **H** Core: 40-44 HRC **S** Ion Nitride 65-70 HRC

▶ CAD insertion point

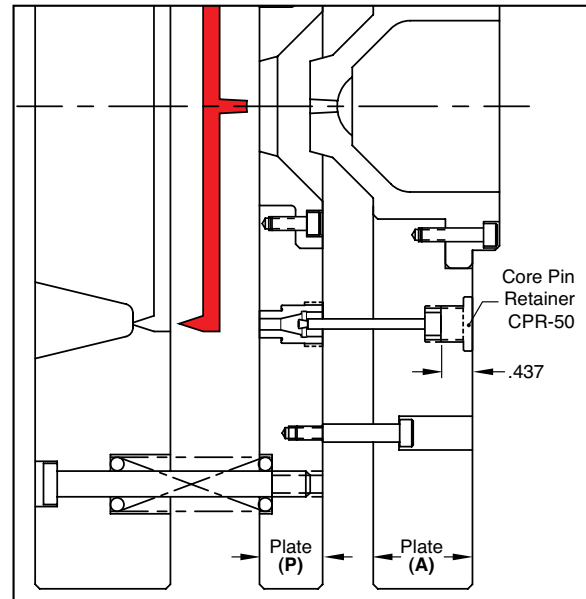
NOMINAL DIAMETER	D	H	T	PL	L=1.813"		L=2.313"		L=2.813"		L=3.313"	
					OAL	CAT. #	OAL	CAT. #	OAL	CAT. #	OAL	CAT. #
5/32	.1562	.28	.156	.125	1.938	PP156L1.9	2.438	PP156L2.4	2.938	PP156L2.9	3.438	PP156L3.4
7/32	.2188	.40	.187	.187	2.000	PP219L2.0	2.500	PP219L2.5	3.000	PP219L3.0	3.500	PP219L3.5
9/32	.2812	.43	.250	.250	2.063	PP281L2.0	2.563	PP281L2.5	3.063	PP281L3.0	3.563	PP281L3.5

Note: Standard "L" provides .010 protrusion per graphic below.

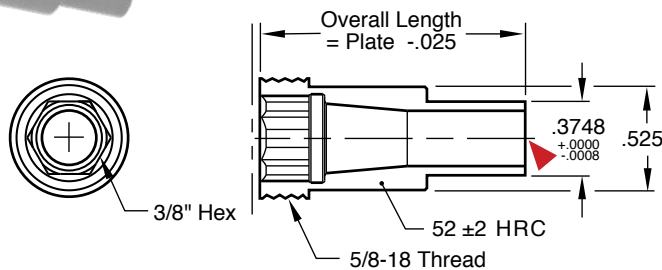
Application



P PLATE THICKNESS	PX REF	X	NOMINAL PIN DIAMETER	PD T.S.C.	R
7/8	1/2	.375	5/32	.145	.020
			7/32	.200	.025
			9/32	.265	.030
1-3/8	7/8	.500	5/32	.145	.020
			7/32	.200	.025
			9/32	.265	.030



PULLER PIN™ BUSHINGS



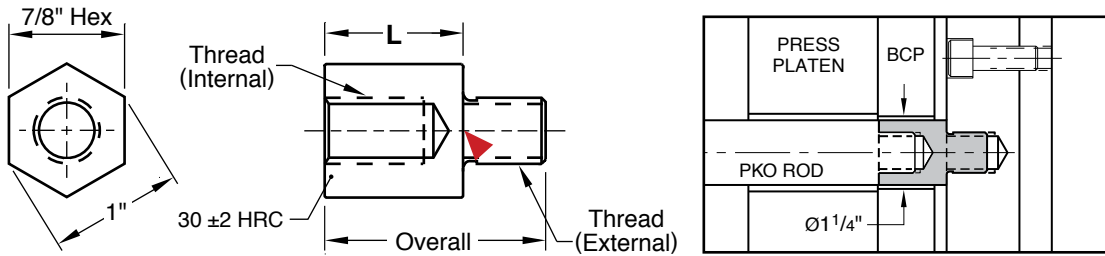
M 440C **H** 50-54 HRC

PULLER PIN DIAMETER	P 7/8" PLATE	P 1-3/8" PLATE
5/32	PPB156L.87	PPB156L1.37
7/32	PPB219L.87	PPB219L1.37
9/32	PPB281L.87	PPB281L1.37

▶ CAD insertion point



PKO™ EXTENSIONS HEX SERIES



M AISI 4140 Pre-Hard **H** 28-32 HRC **S** Black Oxide

▶ CAD insertion point

CATALOG NUMBER	INTERNAL THREAD	EXTERNAL THREAD	OVERALL	L
PH37L10	3/8-16	3/8-16	1.672	1.052
PH50L10	1/2-13	1/2-13		
PH62L10	5/8-11	5/8-11		
PH62L10-50	1/2-13	5/8-11	1.922	1.052
PH75L10	3/4-10	3/4-10		
PH75L10-NT	N/A	3/4-10	1.922	1.302
PH37L13	3/8-16	3/8-16		
PH50L13	1/2-13	1/2-13		
PH62L13	5/8-11	5/8-11	2.172	1.302
PH62L13-50	1/2-13	5/8-11		
PH75L13	3/4-10	3/4-10		
PH75L13-NT	N/A	3/4-10		

CATALOG NUMBER	INTERNAL THREAD	EXTERNAL THREAD	OVERALL	L
PH37L15	3/8-16	3/8-16	2.172	1.552
PH50L15	1/2-13	1/2-13		
PH50L15-NT	N/A	1/2-13		
PH62L15	5/8-11	5/8-11	2.422	1.552
PH75L15	3/4-10	3/4-10		
PH75L15-NT	N/A	3/4-10	2.422	1.802
PH37L18	3/8-16	3/8-16		
PH50L18	1/2-13	1/2-13		
PH50L18-NT	N/A	1/2-13	2.672	1.802
PH62L18	5/8-11	5/8-11		
PH75L18	3/4-10	3/4-10		
PH75L18-NT	N/A	3/4-10		

“L” Dimensions:

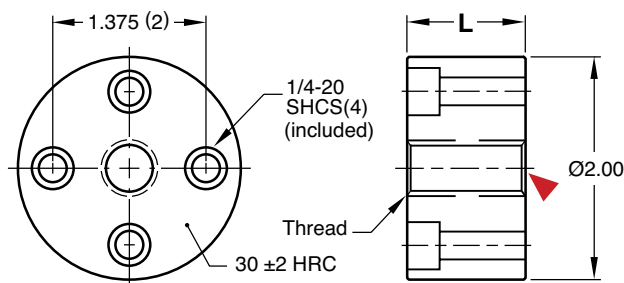
1.052 = .875 (BCP) + .187 (Stop Pins) - .010
 1.302 = .875 (BCP) + .187 (Stop Pins) + .250 (Insulator Plate) - .010

“L” Dimensions:

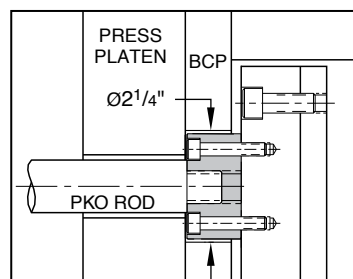
1.552 = 1.375 (BCP) + .187 (Stop Pins) - .010
 1.802 = 1.375 (BCP) + .187 (Stop Pins) + .250 (Insulator Plate) - .010

M AISI 1018 **S** Black Oxide

CATALOG NUMBER	THREAD	L
PKP37L10	3/8-16	1.052
PKP50L10	1/2-13	
PKP62L10	5/8-11	
PKP75L10	3/4-10	1.302
PKPL10-NT	No Thread*	
PKP37L13	3/8-16	
PKP50L13	1/2-13	1.302
PKP62L13	5/8-11	
PKP75L13	3/4-10	
PKPL13-NT	No Thread*	1.552
PKP37L15	3/8-16	
PKP50L15	1/2-13	
PKP62L15	5/8-11	1.552
PKP75L15	3/4-10	
PKPL15-NT	No Thread*	1.802
PKP37L18	3/8-16	
PKP50L18	1/2-13	
PKP62L18	5/8-11	1.802
PKP75L18	3/4-10	
PKPL18-NT	No Thread*	1.802

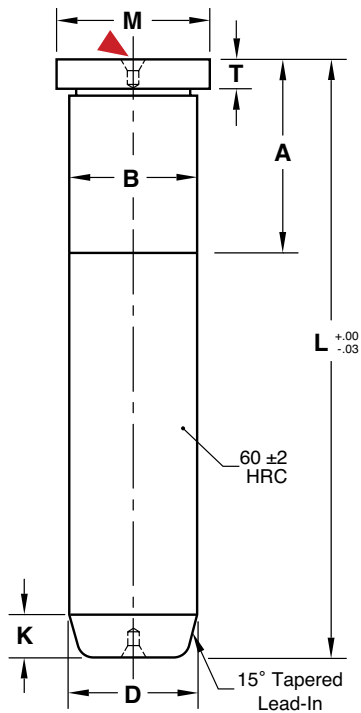


PUCK SERIES



*Mold maker machines thread on “NT” style to suit non-standard applications.

LEADER PINS INCH STANDARD



M AISI 1117 **H** Surface: 58-62 HRC

▶ CAD insertion point

L	D=3/4"		D=7/8"		D=1"		D=1-1/4"	
	A	CATALOG NUMBER	A	CATALOG NUMBER	A	CATALOG NUMBER	A	CATALOG NUMBER
1-3/4	7/8	LP75L1.75	7/8	LP87L1.75	7/8	LP100L1.75	—	—
2-1/4	7/8	LP75L2.25	7/8	LP87L2.25	7/8	LP100L2.25	—	—
2-3/4	7/8	LP75L2.75	7/8	LP87L2.75	7/8	LP100L2.75	7/8	LP125L2.75
3-1/4	7/8	LP75L3.25	7/8	LP87L3.25	7/8	LP100L3.25	7/8	LP125L3.25
3-3/4	7/8	LP75L3.75	7/8	LP87L3.75	7/8	LP100L3.75	7/8	LP125L3.75
4-1/4	1-3/8	LP75L4.25	1-3/8	LP87L4.25	1-3/8	LP100L4.25	7/8	LP125L4.25
4-3/4	1-3/8	LP75L4.75	1-3/8	LP87L4.75	1-3/8	LP100L4.75	1-3/8	LP125L4.75
5-1/4	1-3/8	LP75L5.25	1-3/8	LP87L5.25	1-3/8	LP100L5.25	1-3/8	LP125L5.25
5-3/4	1-7/8	LP75L5.75	1-3/8	LP87L5.75	1-3/8	LP100L5.75	1-3/8	LP125L5.75
6-1/4	1-7/8	LP75L6.25	1-3/8	LP87L6.25	1-3/8	LP100L6.25	1-3/8	LP125L6.25
6-3/4	1-7/8	LP75L6.75	1-7/8	LP87L6.75	1-7/8	LP100L6.75	1-7/8	LP125L6.75
7-1/4	1-7/8	LP75L7.25	1-7/8	LP87L7.25	1-7/8	LP100L7.25	1-7/8	LP125L7.25
7-3/4	1-7/8	LP75L7.75	1-7/8	LP87L7.75	1-7/8	LP100L7.75	1-7/8	LP125L7.75
8-1/4	—	—	1-7/8	LP87L8.25	1-7/8	LP100L8.25	1-7/8	LP125L8.25
8-3/4	—	—	1-7/8	LP87L8.75	1-7/8	LP100L8.75	1-7/8	LP125L8.75
9-1/4	1-7/8	LP75L9.25	—	—	1-7/8	LP100L9.25	1-7/8	LP125L9.25
9-3/4	—	—	—	—	1-7/8	LP100L9.75	1-7/8	LP125L9.75
10-1/4	—	—	—	—	1-7/8	LP100L10.25	1-7/8	LP125L10.25
10-3/4	—	—	1-7/8	LP87L10.75	1-7/8	LP100L10.75	1-7/8	LP125L10.75
11-1/4	—	—	—	—	1-7/8	LP100L11.25	1-7/8	LP125L11.25
11-3/4	—	—	—	—	1-7/8	LP100L11.75	1-7/8	LP125L11.75
12-1/4	—	—	1-7/8	LP87L12.25	1-7/8	LP100L12.25	1-7/8	LP125L12.25
12-3/4	—	—	—	—	—	—	1-7/8	LP125L12.75
13-3/4	—	—	—	—	—	—	1-7/8	LP125L13.75
14-3/4	—	—	—	—	—	—	1-7/8	LP125L14.75
15-3/4	—	—	—	—	—	—	1-7/8	LP125L15.75

General Dimensions

NOMINAL DIAMETER	D +.0000 -.0005	M +.00 -.01	T +.000 -.002	B +.0005 -.0000	K
3/4	.749	.990	.187	.751	3/16
7/8	.874	1.115	.250	.876	3/16
1	.999	1.240	.250	1.001	3/16
1-1/4	1.249	1.490	.312	1.251	1/4
1-1/2	1.499	1.740	.312	1.501	1/4
2	1.999	2.240	.312	2.001	1/2
2-1/2	2.499	2.740	.312	2.501	1/2
3	2.999	3.365	.500	3.001	1/2

L	D=1-1/2"		D=2"		D=2-1/2"		D=3"	
	A	CATALOG NUMBER	A	CATALOG NUMBER	A	CATALOG NUMBER	A	CATALOG NUMBER
3-3/4	1-3/8	LP150L3.75	—	—	—	—	—	—
4-1/4	1-3/8	LP150L4.25	—	—	—	—	—	—
4-3/4	1-3/8	LP150L4.75	—	—	—	—	—	—
5-1/4	1-3/8	LP150L5.25	—	—	—	—	—	—
5-3/4	1-3/8	LP150L5.75	1-7/8	LP200L5.75	2-3/8	LP250L5.75	—	—
6-1/4	1-3/8	LP150L6.25	—	—	—	—	—	—
6-3/4	1-3/8	LP150L6.75	1-7/8	LP200L6.75	2-3/8	LP250L6.75	—	—
7-3/4	1-7/8	LP150L7.75	1-7/8	LP200L7.75	2-3/8	LP250L7.75	—	—
8-3/4	1-7/8	LP150L8.75	1-7/8	LP200L8.75	2-3/8	LP250L8.75	2-7/8	LP300L8.75
9-3/4	1-7/8	LP150L9.75	1-7/8	LP200L9.75	2-3/8	LP250L9.75	—	—
10-3/4	1-7/8	LP150L10.75	1-7/8	LP200L10.75	2-3/8	LP250L10.75	2-7/8	LP300L10.75
11-3/4	1-7/8	LP150L11.75	1-7/8	LP200L11.75	2-3/8	LP250L11.75	—	—
12-3/4	1-7/8	LP150L12.75	1-7/8	LP200L12.75	2-3/8	LP250L12.75	2-7/8	LP300L12.75
13-3/4	1-7/8	LP150L13.75	1-7/8	LP200L13.75	2-3/8	LP250L13.75	—	—
14-3/4	1-7/8	LP150L14.75	1-7/8	LP200L14.75	2-3/8	LP250L14.75	2-7/8	LP300L14.75
15-3/4	1-7/8	LP150L15.75	1-7/8	LP200L15.75	2-3/8	LP250L15.75	—	—
16-3/4	—	—	2-3/8	LP200L16.75	2-3/8	LP250L16.75	2-7/8	LP300L16.75
18-3/4	—	—	2-3/8	LP200L18.75	2-3/8	LP250L18.75	2-7/8	LP300L18.75

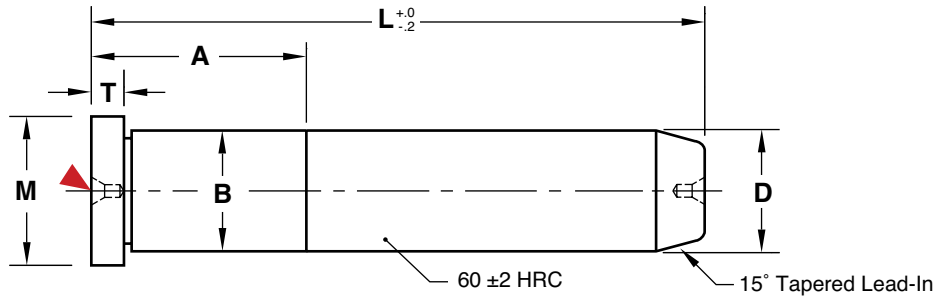
ALTERNATIVE CONFIGURATIONS AVAILABLE

- For Leader Pins with a 7/8" press fit for guided ejection applications, please refer to page B-10.
- For Metric DIN standard Leader Pins, refer to page B-9.
- For Black Nitride inch standard Leader Pins, refer to page B-12.



LEADER PINS

METRIC DIN STANDARD



General Dimensions

D -.007 -.026	B +.011 +.002	M +.0 -.2	T
20	20	24	8
25	25	28	15
30	30	36	15

▶ CAD insertion point

M AISI 1117 (1.7131) **H** Core: Approx. 25 HRC, Surface: 58-62 HRC

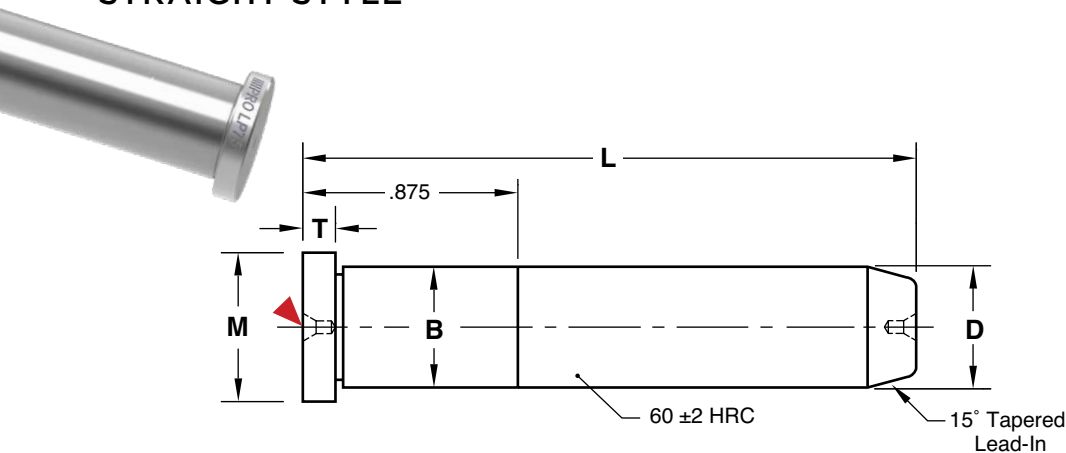
L	D=20MM		D=25MM		D=30MM	
	A	CATALOG NUMBER	A	CATALOG NUMBER	A	CATALOG NUMBER
100	28	LPD20L100	35	LPD25L100	45	LPD30L100
120	28	LPD20L120	35	LPD25L120	45	LPD30L120
140	28	LPD20L140	35	LPD25L140	45	LPD30L140
160	—	—	—	—	45	LPD30L160

ALTERNATIVE CONFIGURATIONS AVAILABLE

- Metric DIN Guided Ejector Bushings are available on page B-16.
- DIN Leader Pins are available with Black Nitride treatment. To order, specify “-BN” at the end of the catalog number. Ex: LPD25L140-BN.
- For inch standard Leader Pins, refer to page B-8 and B-12.

GUIDED EJECTOR PINS

STRAIGHT STYLE



General Dimensions

NOMINAL DIAMETER	D +.0000 -.0005	B +.0005 -.0000	M +.00 -.01	T +.000 -.002
1/2	.499	.501	.740	.187
3/4	.749	.751	.990	.187
7/8	.874	.876	1.115	.250
1	.999	1.001	1.240	.250
1-1/4	1.249	1.251	1.490	.312
1-1/2	1.499	1.501	1.740	.312
2	1.999	2.001	2.240	.312

M AISI 1117 **H** Core: Approx. 25 HRC, Surface: 58-62 HRC

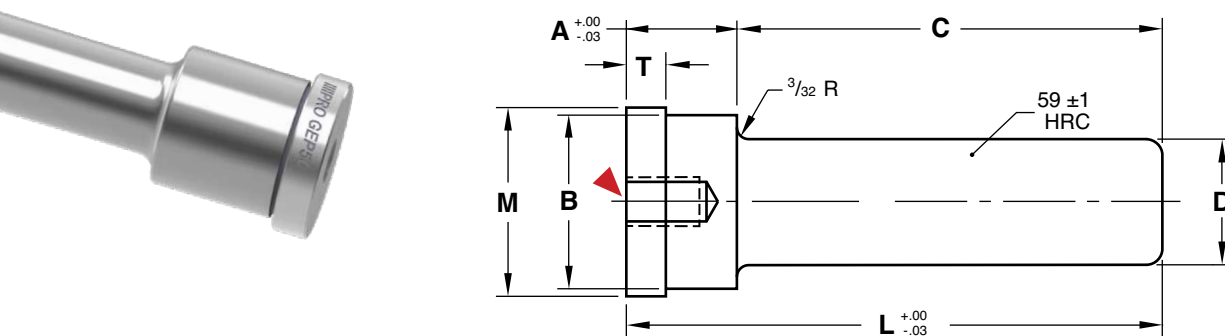
CAD insertion point

L +.00 -.03	D=1/2"	D=3/4"	D=7/8"	D=1"	D=1-1/4"	D=1-1/2"	D=2"
4-1/4	LP50L4.25-P	LP75L4.25-P	LP87L4.25-P	LP100L4.25-P	LP125L4.25	LP150L4.25-P	—
4-3/4	LP50L4.75-P	LP75L4.75-P	LP87L4.75-P	LP100L4.75-P	LP125L4.75-P	LP150L4.75-P	—
5-1/4	—	LP75L5.25-P	LP87L5.25-P	LP100L5.25-P	LP125L5.25-P	LP150L5.25-P	—
5-3/4	—	LP75L5.75-P	LP87L5.75-P	LP100L5.75-P	LP125L5.75-P	LP150L5.75-P	LP200L5.75-P
6-1/4	—	LP75L6.25-P	LP87L6.25-P	LP100L6.25-P	LP125L6.25-P	LP150L6.25-P	LP200L6.25-P

ALTERNATIVE CONFIGURATIONS AVAILABLE

- Leader Pins with 1-3/8" and other press fit lengths are available on page B-8.
- Guided Ejector Pins are available with Black Nitride treatment. To order, specify "-BN" at the end of the catalog number. Ex: LP100L6.25-P-BN (above) or GEP50X87L425-BN from the chart below.
- For Black Nitride inch Standard Leader Pins, refer to page B-12.

SHOULDER STYLE



General Dimensions

NOMINAL DIAMETER	D +.0000 -.0005	B +.0005 -.0000	M +.00 -.01	T +.000 -.015
1/2	.499	.751	.853	.187
3/4	.749	1.126	1.250	.312
1	.999	1.376	1.500	.312

M AISI 8620 **H** Core: Approx. 25 HRC, Surface: 58-60 HRC

CAD insertion point

A	C	L	D=1/2"	D=3/4"	D=1"
7/8	2-7/8	3-3/4	GEP50X87L375	—	—
	3-3/8	4-1/4	GEP50X87L425	GEP75X87L425	GEP100X87L425
	3-7/8	4-3/4	GEP50X87L475	GEP75X87L475	GEP100X87L475
	4-3/8	5-1/4	GEP50X87L525	GEP75X87L525	GEP100X87L525
1-3/8	4-7/8	5-3/4	—	GEP75X87L575	GEP100X87L575
	3-7/8	5-1/4	—	—	GEP100X137L525
	4-3/8	5-3/4	—	—	GEP100X137L575
	4-7/8	6-1/4	—	—	GEP100X137L625



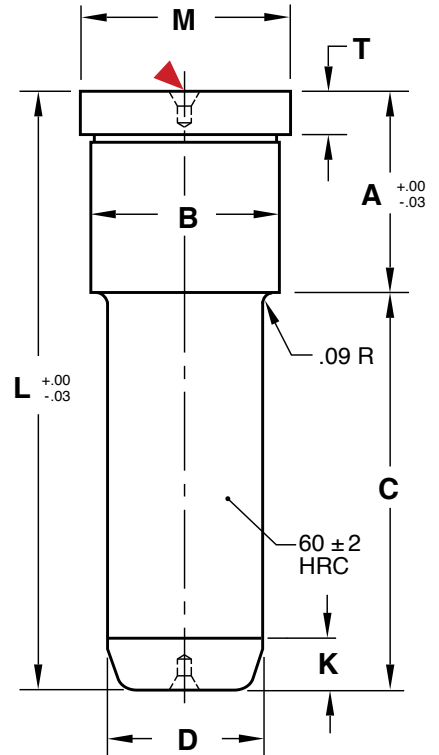
LEADER PINS SHOULDER STYLE



M AISI 1117 **H** Surface: 58-62 HRC

CAD insertion point

A	C	L	D=1/2"	D=3/4"	D=1"	D=1-1/4"
7/8	7/8	1-3/4	SLP50X87L175	SLP75X87L175	—	—
	1-3/8	2-1/4	SLP50X87L225	SLP75X87L225	—	—
	1-7/8	2-3/4	SLP50X87L275	—	—	—
	2-3/8	3-1/4	SLP50X87L325	SLP75X87L325	—	—
	2-7/8	3-3/4	—	SLP75X87L375	SLP100X87L375	—
1-3/8	7/8	2-1/4	SLP50X137L225	SLP75X137L225	—	—
	1-3/8	2-3/4	SLP50X137L275	SLP75X137L275	SLP100X137L275	—
	1-7/8	3-1/4	SLP50X137L325	SLP75X137L325	SLP100X137L325	—
	2-3/8	3-3/4	—	SLP75X137L375	—	—
	2-7/8	4-1/4	—	SLP75X137L425	SLP100X137L425	—
	3-3/8	4-3/4	—	SLP75X137L475	—	SLP125X137L475
1-7/8	7/8	2-3/4	SLP50X187L275	—	—	—
	1-3/8	3-1/4	SLP50X187L325	SLP75X187L325	—	—
	1-7/8	3-3/4	SLP50X187L375	SLP75X187L375	SLP100X187L375	—
	2-3/8	4-1/4	—	SLP75X187L425	SLP100X187L425	SLP125X187L425
	2-7/8	4-3/4	—	SLP75X187L475	SLP100X187L475	—
	3-3/8	5-1/4	—	SLP75X187L525	—	—
	3-7/8	5-3/4	—	SLP75X187L575	—	SLP125X187L575
2-3/8	7/8	3-1/4	SLP50X237L325	—	—	—
	1-3/8	3-3/4	—	SLP75X237L375	—	—
	1-7/8	4-1/4	—	SLP75X237L425	SLP100X237L425	—
	2-3/8	4-3/4	—	SLP75X237L475	SLP100X237L475	—
	2-7/8	5-1/4	—	SLP75X237L525	—	SLP125X237L525
	3-3/8	5-3/4	—	—	SLP100X237L575	—
	3-7/8	6-1/4	—	—	—	SLP125X237L625
2-7/8	1-3/8	4-1/4	—	SLP75X287L425	—	—
	1-7/8	4-3/4	—	SLP75X287L475	SLP100X287L475	—
	2-3/8	5-1/4	—	SLP75X287L525	SLP100X287L525	—
	2-7/8	5-3/4	—	SLP75X287L575	SLP100X287L575	SLP125X287L575
	3-3/8	6-1/4	—	—	SLP100X287L625	—
	3-7/8	6-3/4	—	SLP75X287L675	—	—
	4-3/8	7-1/4	—	—	—	SLP125X287L725
3-3/8	2-3/8	5-3/4	—	SLP75X337L575	—	—
	3-3/8	6-3/4	—	SLP75X337L675	—	—
	4-3/8	7-3/4	—	—	SLP100X337L775	—
3-7/8	2-3/8	6-1/4	—	SLP75X387L625	SLP100X387L625	—
	2-7/8	6-3/4	—	SLP75X387L675	SLP100X387L675	—
4-3/8	2-7/8	7-1/4	—	—	SLP100X437L725	—
	3-3/8	7-3/4	—	—	—	SLP125X437L775
4-7/8	3-7/8	8-3/4	—	—	SLP100X487L875	SLP125X487L875
5-7/8	3-7/8	9-3/4	—	—	SLP100X587L975	—
	5-7/8	11-3/4	—	—	—	SLP125X587L1175



General Dimensions

NOM. DIA.	D +.0000 -.0005	B +.0005 -.0000	M +.00 -.01	T +.000 -.002	K
1/2	.499	.751	.853	.187	3/16
3/4	.749	1.126	1.250	.312	3/16
1	.999	1.376	1.500	.312	3/16
1-1/4	1.249	1.626	1.750	.312	1/4

ALTERNATIVE CONFIGURATIONS AVAILABLE

- Shoulder Leader Pins are available with Black Nitride treatment. To order, specify "-BN" at the end of the catalog number. Ex: SLP75X387L625-BN

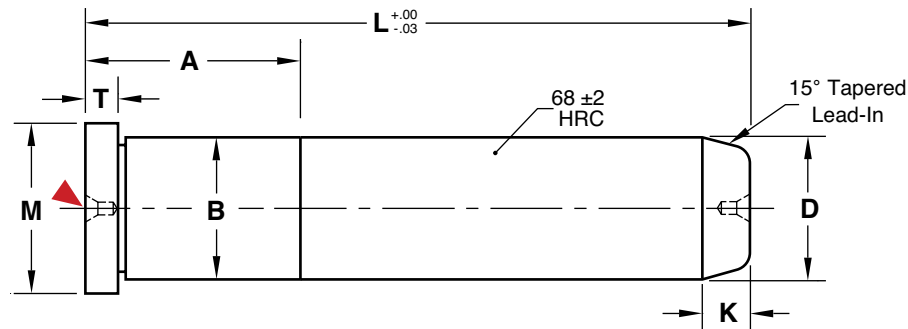
LEADER PINS

INCH STANDARD-BLACK NITRIDE



General Dimensions

NOMINAL DIAMETER	D ±.0005	M +.00 -.01	T +.000 -.002	B +.0005 -.0000	K
1	.999	1.240	.250	1.001	3/16
1-1/4	1.249	1.490	.312	1.251	1/4
1-1/2	1.499	1.740	.312	1.501	1/4
2	1.999	2.240	.312	2.001	1/2
2-1/2	2.499	2.740	.312	2.501	1/2
3	2.999	3.365	.500	3.001	1/2



M AISI 1117 **H** Surface: 66-70 HRC **S** Black Nitride

CAD insertion point

L	D=1"		D=1-1/4"		D=1-1/2"		D=2"		D=2-1/2"		D=3"	
	A	CATALOG NUMBER	A	CATALOG NUMBER	A	CATALOG NUMBER	A	CATALOG NUMBER	A	CATALOG NUMBER	A	CATALOG NUMBER
7-1/4	1-7/8	LP100L7.25-BN	-	-	-	-	-	-	-	-	-	-
7-3/4	1-7/8	LP100L7.75-BN	1-7/8	LP125L7.75-BN	1-7/8	LP150L7.75-BN	1-7/8	LP200L7.75-BN	-	-	-	-
8-1/4	-	-	1-7/8	LP125L8.25-BN	-	-	-	-	-	-	-	-
8-3/4	-	-	-	-	1-7/8	LP150L8.75-BN	1-7/8	LP200L8.75-BN	2-3/8	LP250L8.75-BN	2-7/8	LP300L8.75-BN
9-3/4	-	-	-	-	-	-	1-7/8	LP200L9.75-BN	2-3/8	LP250L9.75-BN	-	-
10-3/4	-	-	1-7/8	LP125L10.75-BN	1-7/8	LP150L10.75-BN	1-7/8	LP200L10.75-BN	2-3/8	LP250L10.75-BN	2-7/8	LP300L10.75-BN
12-3/4	-	-	-	-	-	-	-	-	-	-	2-7/8	LP300L12.75-BN
15-3/4	-	-	-	-	-	-	1-7/8	LP200L15.75-BN	2-3/8	LP250L15.75-BN	-	-
18-3/4	-	-	-	-	-	-	2-3/8	LP200L18.75-BN	2-3/8	LP250L18.75-BN	2-7/8	LP300L18.75-BN

ALTERNATIVE CONFIGURATIONS AVAILABLE

- Any standard Leader Pin can be treated with Black Nitride. Add "-BN" to the catalog number and contact Customer Service for a quotation.
- For Leader Pins with a 7/8" press fit for guided ejection applications, please refer to page B-10.



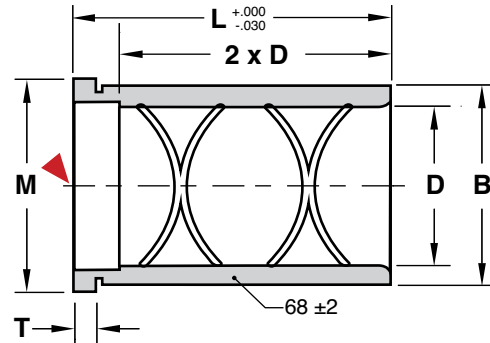
BUSHINGS

INCH STANDARD SHOULDER STYLE-BLACK NITRIDE



General Dimensions

NOMINAL DIAMETER	D +.0005 -.0000	B +.0005 -.0000	M +.00 -.01	T +.00 -.01
1	1.0005	1.3755	1.552	.187
1-1/4	1.2505	1.6255	1.802	.187
1-1/2	1.5005	2.0005	2.177	.187
2	2.0005	2.5005	2.677	.187
2-1/2	2.5005	3.2505	3.427	.187
3	3.0005	3.7505	3.990	.500

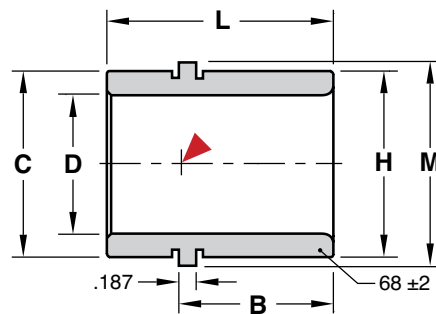


M AISI 1117 **H** Surface: 66-70 HRC **S** Black Nitride

▶ CAD insertion point

L	D=1"	D=1-1/4"	D=1-1/2"	D=2"	D=2-1/2"	D=3"
4-7/8	STL100L4.87-BN	STL125L4.87-BN	STL150L4.87-BN	STL200L4.87-BN	STL250L4.87-BN	STL300L4.87-BN
5-7/8	STL100L5.87-BN	STL125L5.87-BN	STL150L5.87-BN	STL200L5.87-BN	STL250L5.87-BN	STL300L5.87-BN
7-7/8	—	—	—	—	—	STL300L7.87-BN

INCH STANDARD GUIDED EJECTOR-BLACK NITRIDE



M AISI 1117 **H** Surface: 66-70 HRC **S** Black Nitride

CATALOG NUMBER	NOMINAL DIAMETER	D +.0005 -.0000	H +.0005 -.0000	C +.000 -.001	M +.00 -.01	B	L +.00 -.03
GEB50-BN	1/2	.5005	.7505	.7490	.853	1.00	1.50
GEB75-BN	3/4	.7505	1.1255	1.1240	1.302	1.00	1.50
GEB87-BN	7/8	.8755	1.2505	1.2490	1.427	1.00	1.50
GEB100-BN	1	1.0005	1.3755	1.3740	1.552	1.12	1.75
GEB125-BN	1-1/4	1.2505	1.6255	1.6240	1.802	1.12	1.75
GEB150-BN	1-1/2	1.5005	2.0005	1.9990	2.177	1.12	1.75
GEB200-BN	2	2.0005	2.5005	2.4990	2.687	1.62	2.25

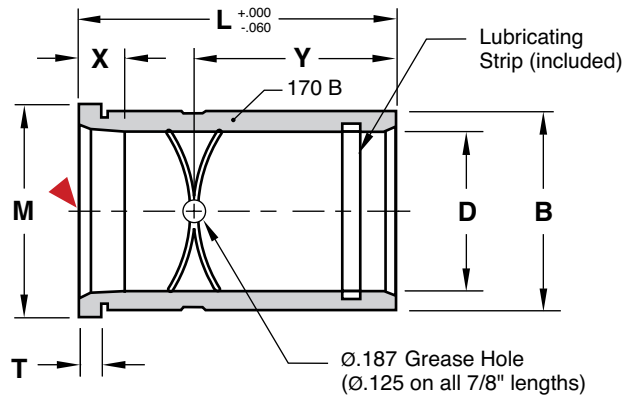
BUSHINGS

SHOULDER STYLE-SOLID BRONZE



General Dimensions

NOMINAL DIAMETER	D +.0005 -.0000	B +.0005 -.0000	M +.00 -.01	T +.00 -.01
1/2	.5005	.7505	.853	.187
3/4	.7505	1.1255	1.302	.187
7/8	.8755	1.2505	1.427	.187
1	1.0005	1.3755	1.552	.187
1-1/4	1.2505	1.6255	1.802	.187
1-1/2	1.5005	2.0005	2.177	.187
2	2.0005	2.5005	2.677	.187
2-1/2	2.5005	3.2505	3.427	.187
3	3.0005	3.7505	3.990	.500



M CA954 Solid Bronze **H** 170 Brinell

CAD insertion point

L	D=1/2"	D=3/4"	D=7/8"	D=1"	D=1-1/4"	D=1-1/2"	D=2"	D=2-1/2"	D=3"
7/8	SAB50L.87	SAB75L.87	SAB87L.87	SAB100L.87	SAB125L.87	SAB150L.87	—	—	—
1-3/8	SAB50L1.37	SAB75L1.37	SAB87L1.37	SAB100L1.37	SAB125L1.37	SAB150L1.37	SAB200L1.37	SAB250L1.37	—
1-7/8	SAB50L1.87	SAB75L1.87	SAB87L1.87	SAB100L1.87	SAB125L1.87	SAB150L1.87	SAB200L1.87	SAB250L1.87	—
2-3/8	SAB50L2.37	SAB75L2.37	SAB87L2.37	SAB100L2.37	SAB125L2.37	SAB150L2.37	SAB200L2.37	SAB250L2.37	—
2-7/8	—	SAB75L2.87	SAB87L2.87	SAB100L2.87	SAB125L2.87	SAB150L2.87	SAB200L2.87	SAB250L2.87	—
3-3/8	—	SAB75L3.37	SAB87L3.37	SAB100L3.37	SAB125L3.37	SAB150L3.37	SAB200L3.37	SAB250L3.37	—
3-7/8	—	SAB75L3.87	SAB87L3.87	SAB100L3.87	SAB125L3.87	SAB150L3.87	SAB200L3.87	SAB250L3.87	SAB300L3.87
4-3/8	—	SAB75L4.37	SAB87L4.37	SAB100L4.37	SAB125L4.37	SAB150L4.37	SAB200L4.37	SAB250L4.37	—
4-7/8	—	SAB75L4.87	SAB87L4.87	SAB100L4.87	SAB125L4.87	SAB150L4.87	SAB200L4.87	SAB250L4.87	SAB300L4.87
5-7/8	—	SAB75L5.87	SAB87L5.87	SAB100L5.87	SAB125L5.87	SAB150L5.87	SAB200L5.87	SAB250L5.87	SAB300L5.87
7-7/8	—	—	—	—	—	—	—	—	SAB300L7.87

Grease Hole and Clearance Dimensions

L	D=1/2- 7/8"		D=1"		D=1-1/4"		D=1-1/2"		D=2"		D=2-1/2- 3"	
	X	Y	X	Y	X	Y	X	Y	X	Y	X	Y
7/8	—	.43	—	.43	—	.43	—	.43	—	—	—	—
1-3/8	—	.62	—	.62	—	.62	—	.62	—	.62	—	.62
1-7/8	—	.62	—	.62	—	.62	—	.62	—	.62	—	.62
2-3/8	.50	.81	—	.81	—	.81	—	.81	—	.81	—	.81
2-7/8	.50	.81	.50	.81	—	.81	—	.81	—	.81	—	.81
3-3/8	1.00	.81	.50	.81	.50	.81	—	.81	—	.81	—	.81
3-7/8	1.00	.81	.50	.81	.50	.81	.50	.81	—	.81	—	.81
4-3/8	1.50	.81	1.00	.81	1.00	.81	.50	.81	—	.81	—	.81
4-7/8	1.50	.81	1.00	.81	1.00	.81	1.00	.81	.50	1.31	—	1.31
5-7/8	2.00	.81	1.50	.81	1.50	.81	1.50	.81	1.00	1.31	.50	1.31
7-7/8	—	—	—	—	—	—	—	—	—	—	.50	1.31

Note: To order replacement lubricating strips, specify the prefix "BSHSTRP" with the inner diameter. Ex: BSHSTRP-125.



BUSHINGS SHOULDER STYLE

BRONZE PLATED SHOULDER BUSHINGS

M AISI 1026 **H** 22-28 HRC **S** Bronze Plated: .004" Deep

- Bronze plated shoulder bushings have internal grease grooves. Grease entry hole to be machined by mold maker.
- The bearing of the inner diameter is through, where the clearance "X" on page B-14 does not apply.
- Not available in 1/2" diameter.



To Order: Specify "SHB" in the prefix to replace "SAB" in the chart on the previous page.
Example: SHB200L2.37 for 2" ID x 2.37 long bushings.

GRAPHITE PLUGGED SHOULDER BUSHINGS

M CA954 with oil impregnated graphite plugs **H** 170 Brinell

- Graphite plugs are not compatible with grease. Use a light 20 weight oil at startup to begin lubrication.
- The bearing of the inner diameter is through, where the clearance "X" on page B-14 does not apply.
- Not available in 1/2" diameter.

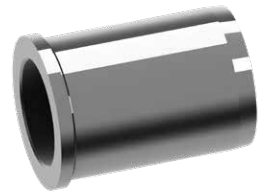


To Order: Specify "SGP" in the prefix to replace "SAB" in the chart on the previous page.
Example: SGP200L2.37 for 2" ID x 2.37 long bushings.

STEEL SHOULDER BUSHINGS

M AISI 1117 **H** 58-62 HRC

- Steel (hardened) shoulder bushings have internal grease grooves. Grease entry hole to be machined by mold maker.
- The bearing of the inner diameter is 2 x the ID, where the clearance "X" on page B-14 does not apply.
- Steel Bushings are available with Black Nitride treatment. Refer to page B-13.



To Order: Specify "STL" in the prefix to replace "SAB" in the chart on the previous page.
Example: STL200L2.37 for 2" ID x 2.37 long bushings.

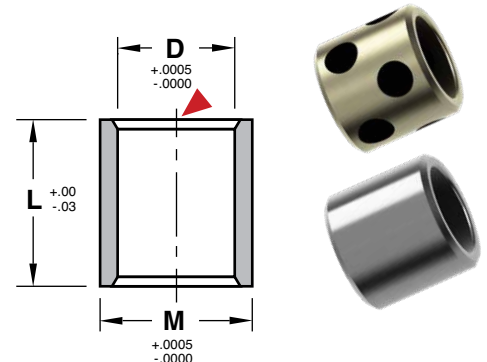
M Non-Plated Steel: AISI 1117 **H** 58-62 HRC

M Graphite Plugged: CA954 **H** 170 Brinell

CAD insertion point

NOMINAL DIAMETER	D +.0005 -.0000	M +.0005 -.0000	L +.00 -.03	CATALOG NUMBER STANDARD STEEL	CATALOG NUMBER GRAPHITE PLUGGED
1/2	.5005	.7505	7/8 1-3/8	STB50L.87 STB50L1.37	— —
3/4	.7505	1.1255	7/8 1-3/8	STB75L.87 STB75L1.37	STGP75L.87 STGP75L1.37
7/8	.8755	1.2505	1-3/8 1-1/2	STB87L1.37 —	— STGP87L1.50
1	1.0005	1.3755	1-3/8	STB100L1.37	STGP100L1.37
1-1/4	1.2505	1.6255	1-3/8 1-7/8	STB125L1.37 STB125L1.87	STGP125L1.37 STGP125L1.87
1-1/2	1.5005	2.0005	1-3/8 1-7/8	STB150L1.37 STB150L1.87	STGP150L1.37 STGP150L1.87
2	2.0005	2.5005	3-7/8	STB200L3.87	STGP200L3.87
2-1/2	2.5005	3.2505	4-7/8	STB250L4.87	STGP250L4.87

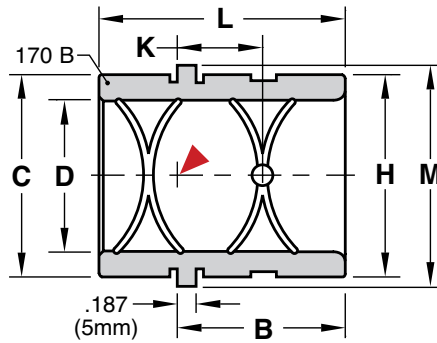
STRAIGHT STYLE



Using grease will inhibit the function of the graphite plugs. Instead, use a light 20 weight oil at startup to begin lubrication.

GUIDED EJECTOR BUSHINGS

SOLID BRONZE



M CA954 Solid Bronze **H** 170 Brinell

Inch Standard

▶ CAD insertion point

CATALOG NUMBER	NOMINAL DIAMETER	D +.0005 -.0000	H +.0005 -.0000	C +.000 -.001	M +.00 -.01	B	K	L +.00 -.03
GEB50	1/2	.5005	.7505	.7490	.853	1.00	.56	1.50
GEB75	3/4	.7505	1.1255	1.1240	1.302	1.00	.56	1.50
GEB87	7/8	.8755	1.2505	1.2490	1.427	1.00	.56	1.50
GEB100	1	1.0005	1.3755	1.3740	1.552	1.12	.62	1.75
GEB125	1-1/4	1.2505	1.6255	1.6240	1.802	1.12	.62	1.75
GEB150	1-1/2	1.5005	2.0005	1.9990	2.177	1.12	.62	1.75
GEB200	2	2.0005	2.5005	2.4990	2.687	1.62	.80	2.25

Metric Standard

CATALOG NUMBER	D +.013 +.026	H +.01 -.00	C -.01 -.03	M +.00 -.13	B	K	L +.0 -.8
GEBD20	20	26	26	28	25	15	37
GEBD25	25	32	32	35	29	16	45
GEBD30	30	38	38	41	29	16	45

Metric DIN Leader Pins are sold on page B-9.

GRAPHITE PLUGGED



Using grease will inhibit the function of the graphite plugs. Instead, use a light 20 weight oil at startup to begin lubrication.

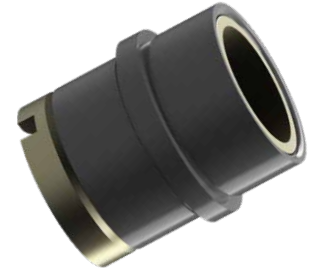
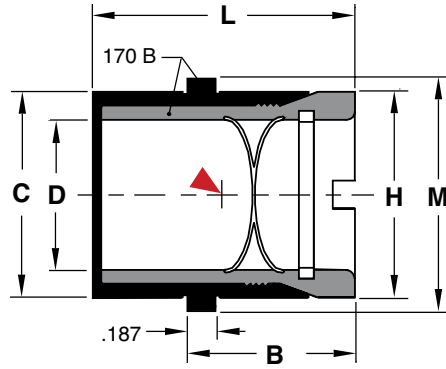
M CA954 with oil impregnated graphite plugs **H** 170 Brinell

CATALOG NUMBER	NOMINAL DIAMETER	D +.0005 -.0000	H +.0005 -.0000	C +.000 -.001	M +.00 -.01	B	L +.00 -.03
GGP75	3/4	.751	1.1255	1.1240	1.302	1.00	1.50
GGP87	7/8	.876	1.2505	1.2490	1.427	1.00	1.50
GGP100	1	1.001	1.3755	1.3740	1.552	1.12	1.75
GGP125	1-1/4	1.251	1.6255	1.6240	1.802	1.12	1.75
GGP150	1-1/2	1.501	2.0005	1.9990	2.177	1.12	1.75
GGP200	2	2.001	2.5005	2.4990	2.687	1.62	2.25



GUIDED EJECTOR BUSHINGS

QC™ BUSHINGS



Liner: **M** CA954 Solid Bronze **H** 170 Brinell

Body: **M** AISI 12L14

H 170 Brinell **S** Black Oxide

CAD insertion point

APPLICATION GUIDELINES

- QC Bushings are sold in assembly.
- Replacement liners are sold below. For additional sizes, contact Customer Service.
- To order replacement lubricating strips, specify the prefix "BSHSTRP" with the inner diameter. Ex: BSHSTRP-125.

CATALOG NUMBER	NOMINAL DIAMETER	D +.0005 -.0000	H +.0005 -.0000	C +.000 -.001	M +.00 -.01	B	L +.000 -.015
GQC50	1/2	.5005	.7505	.7490	.853	1.00	1.50
GQC75	3/4	.7505	1.1255	1.1240	1.302	1.00	1.50
GQC87	7/8	.8755	1.2505	1.2490	1.427	1.00	1.50
GQC100	1	1.0005	1.3755	1.3740	1.552	1.12	1.75
GQC125	1-1/4	1.2505	1.6255	1.6240	1.802	1.12	1.75
GQC150	1-1/2	1.5005	2.0005	1.9990	2.177	1.12	1.75

REPLACEMENT LINERS

M CA954 Solid Bronze **H** 170 Brinell



INNER DIAMETER	LINER CATALOG NUMBER	FITS BUSHINGS
1/2	BL50L1.50	GQC50
3/4	BL75L.87	SQC75L.87
		GQC75
		SQC75L1.37
	BL75L1.37	SQC75L1.87
		SQC75L2.37
		SQC75L2.87
7/8	BL87L.87	SQC87L.87
		GQC87
	BL87L1.37	SQC87L1.37
		SQC87L1.87
		SQC87L2.37
		SQC87L2.87
		SQC87L2.87
INNER DIAMETER	LINER CATALOG NUMBER	FITS BUSHINGS
1	BL100L1.37	SQC100L1.37
		GQC100
	BL100L1.75	SQC100L1.87
		SQC100L2.37
		SQC100L3.37
1-1/4	BL125L1.37	SQC125L1.37
		GQC125
	BL125L1.75	SQC125L1.87
		SQC125L2.37
1-1/2	BL125L2.37	SQC125L2.87
		SQC125L3.37
	BL150L1.75	GQC150
		SQC150L1.87

APPLICATION GUIDELINES

- To order replacement lubricating strips, specify the prefix "BSHSTRP" with the inner diameter. Ex: BSHSTRP-125.
- Note: References to "SQC" Shoulder Bushings are for legacy tools. For tools requiring Shoulder Bushings, please refer to pages B-14 through B-15.

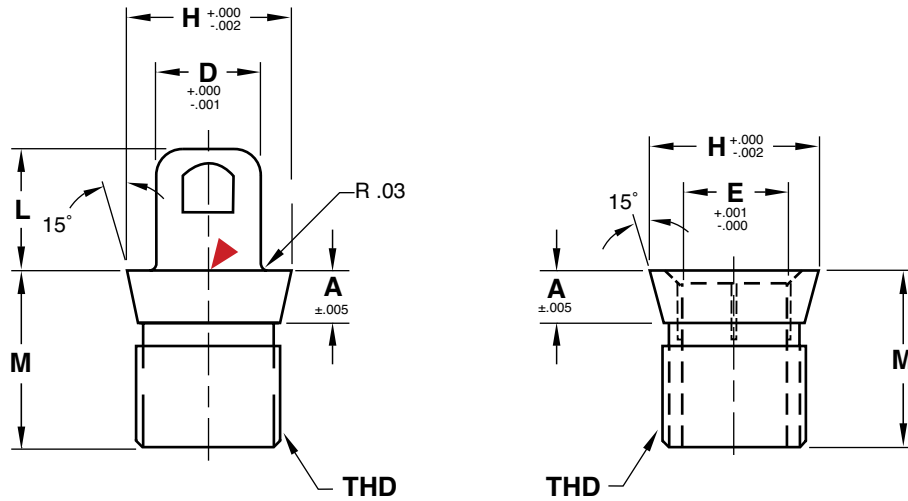
SPANNER WRENCH

M Hardened Steel

CATALOG NUMBER	DESCRIPTION
SW-100	Adjustable Spanner Wrench



FRONT LOADING PINS AND BUSHINGS



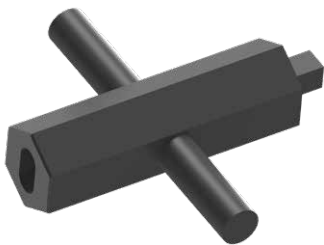
M H-13 **H** Core: 40-45 HRC, Surface: 65-70 HRC **S** Nitride

CAD insertion point

CATALOG NUMBER	NOMINAL DIAMETER	D	E	THD UNF	H	L	M	A
FLPB31L.62	5/16	.3125	.3130	1/2-20	.609	.62	.670	.20
FLPB43L.57	7/16	.4375	.4380	5/8-18	.747	.57	.850	.25
FLPB43L.75	7/16	.4375	.4380	5/8-18	.747	.75	.850	.25
FLPB50L.58	1/2	.5000	.5005	11/16-16	.807	.58	.845	.25
FLPB75L.70	3/4	.7500	.7505	1-12	1.115	.70	1.255	.25
FLPB75L1.10	3/4	.7500	.7505	1-12	1.115	1.10	1.255	.25
FLPB75L1.75	3/4	.7500	.7505	1-12	1.115	1.75	1.255	.25
FLPB100L1.10	1	1.0000	1.0005	1 1/4-16	1.370	1.10	1.224	.25

Sold in sets of (1) Pin and (1) Bushing.

INSTALLATION WRENCH



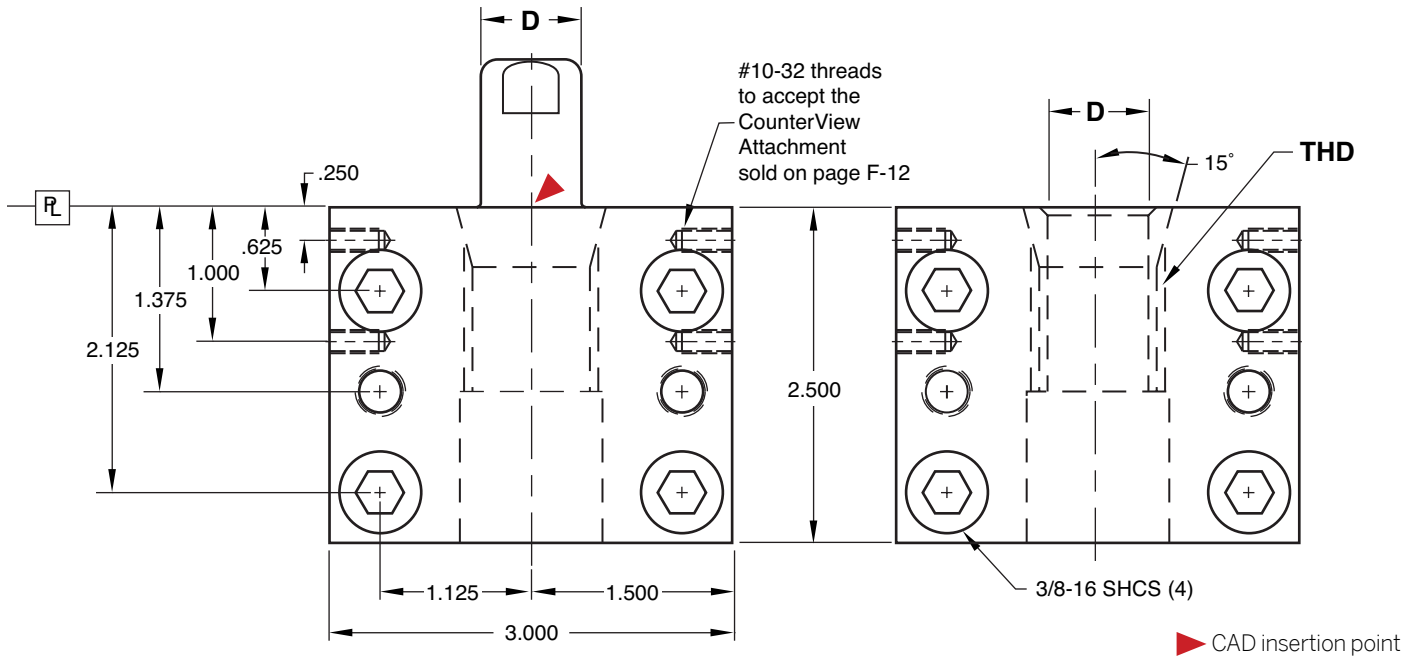
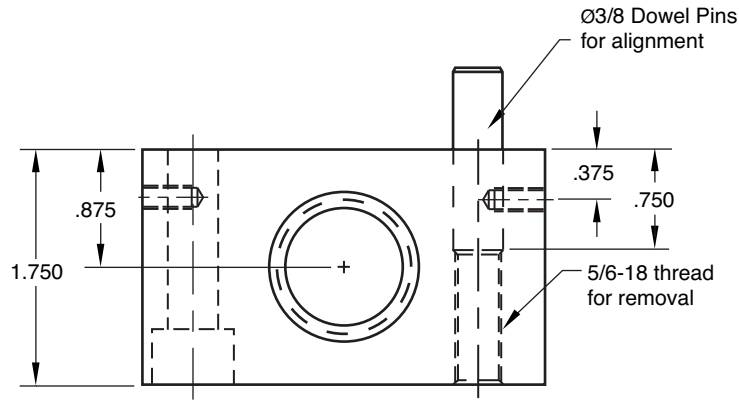
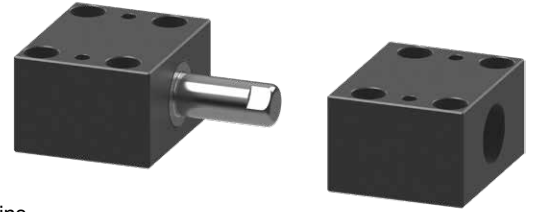
M CRS **H** Case Hardened **S** Black Oxide

CATALOG NUMBER	DESCRIPTION
WR-312	For 5/16" ID Bushing
WR-437	For 7/16" ID Bushing
WR-500	For 1/2" ID Bushing
WR-750	For 3/4" ID Bushing
WR-100	For 1" ID Bushing



GUIDE BLOCKS

FRONT LOADING PINS & BUSHINGS SERIES



M A-36 **H** Pre-Hard **S** Black Oxide

CATALOG NUMBER	D PIN/BUSHING DIAMETER	THD UNF
GBK-75	3/4	1-12
GBK-100	1	1 1/4-16

Sold in sets of (2) identical Blocks.
Pins and Bushings sold separately on page B-18.

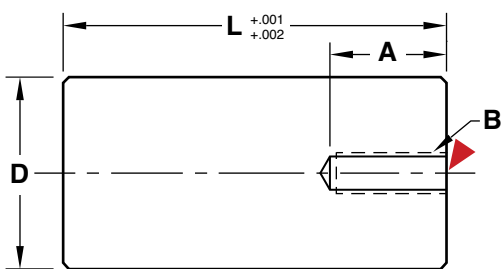
SUPPORT PILLARS



M AISI 1018 **H** 126 Brinell

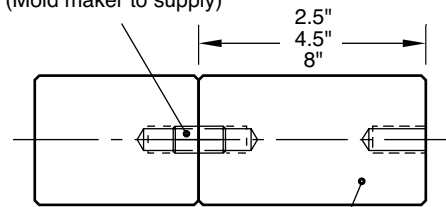
CAD insertion point

Threaded Support Pillars



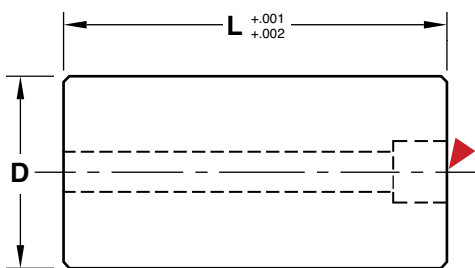
Socket Head Cap Screws are included with all Support Pillars. 1" long screws are used with the Threaded Pillars. Refer to the chart for the Counterbored Pillar screw size.

Optional Set Screw
(Mold maker to supply)



All 2.5", 4.5" and 8" long Threaded Support Pillars are tapped for a set screw enabling a second pillar to be attached as an extension.

Counterbored Support Pillars



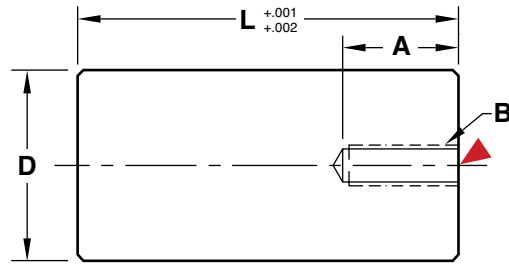
Smaller diameter Support Pillars available on page L-9.

		THREADED SUPPORT PILLARS			COUNTERBORED SUPPORT PILLARS	
D	L	CATALOG NUMBER	A	B	CATALOG NUMBER	SHCS
1	2.5	SP100L2.5	.62	3/8-16	SP100L2.5-CB	3/8-16 x 2-1/2
	3	SP100L3			SP100L3-CB	3/8-16 x 3
	3.5	SP100L3.5			SP100L3.5-CB	3/8-16 x 3-1/2
	4	SP100L4			SP100L4-CB	3/8-16 x 4
	4.5	SP100L4.5			SP100L4.5-CB	3/8-16 x 4-1/2
1-1/4	2.5	SP125L2.5	.62	3/8-16	SP125L2.5-CB	3/8-16 x 2-1/2
	3	SP125L3			SP125L3-CB	3/8-16 x 3
	3.5	SP125L3.5			SP125L3.5-CB	3/8-16 x 3-1/2
	4	SP125L4			SP125L4-CB	3/8-16 x 4
	4.5	SP125L4.5			SP125L4.5-CB	3/8-16 x 4-1/2
	5	SP125L5			SP125L5-CB	3/8-16 x 5
1-1/2	2.5	SP150L2.5	.62	3/8-16	SP150L2.5-CB	3/8-16 x 2-1/2
	3	SP150L3			SP150L3-CB	3/8-16 x 3
	3.5	SP150L3.5			SP150L3.5-CB	3/8-16 x 3-1/2
	4	SP150L4			SP150L4-CB	3/8-16 x 4
	4.5	SP150L4.5			SP150L4.5-CB	3/8-16 x 4-1/2
	5	SP150L5			SP150L5-CB	3/8-16 x 5
	6	SP150L6			SP150L6-CB	3/8-16 x 6
2	2.5	SP200L2.5	.62	3/8-16	SP200L2.5-CB	3/8-16 x 2-1/2
	3	SP200L3			SP200L3-CB	3/8-16 x 3
	3.5	SP200L3.5			SP200L3.5-CB	3/8-16 x 3-1/2
	4	SP200L4			SP200L4-CB	3/8-16 x 4
	4.5	SP200L4.5			SP200L4.5-CB	3/8-16 x 4-1/2
	5	SP200L5			SP200L5-CB	3/8-16 x 5
	6	SP200L6			SP200L6-CB	3/8-16 x 6
	7	SP200L7			SP200L7-CB	3/8-16 x 7
	8	SP200L8			SP200L8-CB	3/8-16 x 8
	9	SP200L9			SP200L9-CB	3/8-16 x 9
2-1/2	3	SP250L3	.62	3/8-16	SP250L3-CB	3/8-16 x 3
	3.5	SP250L3.5			SP250L3.5-CB	3/8-16 x 3-1/2
	4	SP250L4			SP250L4-CB	3/8-16 x 4
	4.5	SP250L4.5			SP250L4.5-CB	3/8-16 x 4-1/2
	5	SP250L5			SP250L5-CB	3/8-16 x 5
	6	SP250L6			SP250L6-CB	3/8-16 x 6
	7	SP250L7			SP250L7-CB	3/8-16 x 7
	8	SP250L8			SP250L8-CB	3/8-16 x 8
3	3.5	SP300L3.5	1.25	5/8-11	SP300L3.5-CB	5/8-11 x 4
	4	SP300L4			SP300L4-CB	5/8-11 x 4-1/2
	4.5	SP300L4.5			SP300L4.5-CB	5/8-11 x 5
	5	SP300L5			SP300L5-CB	5/8-11 x 5-1/2
	6	SP300L6			SP300L6-CB	5/8-11 x 6-1/2
	7	SP300L7			SP300L7-CB	5/8-11 x 7-1/2
	8	SP300L8			SP300L8-CB	5/8-11 x 8-1/2
	9	SP300L9			SP300L9-CB	5/8-11 x 9-1/2
	10	SP300L10			SP300L10-CB	5/8-11 x 10-1/2
	4	5			SP400L5	1.25
6		SP400L6	SP400L6-CB	5/8-11 x 6-1/2		
8		SP400L8	SP400L8-CB	5/8-11 x 8-1/2		



SUPPORT PILLARS

STAINLESS STEEL

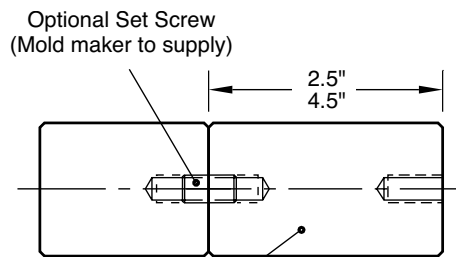


M 410 Stainless Steel **H** 30-34 HRC

CAD insertion point

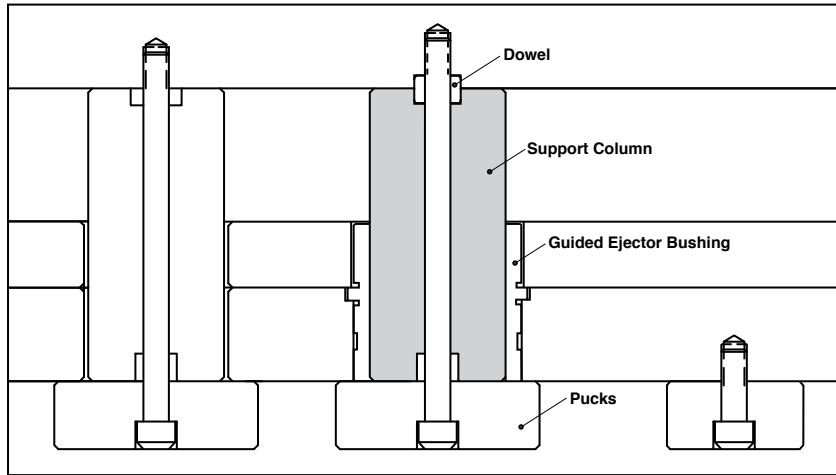
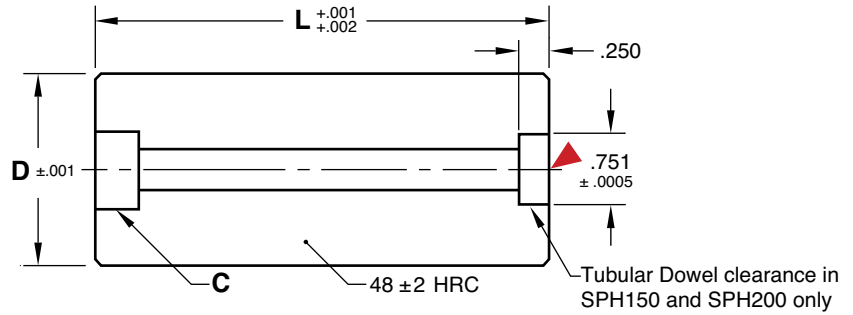
D	CATALOG NUMBER	L	A	B
1	SP100L2.5-SS	2.5	.62	3/8-16
	SP100L3-SS	3		
	SP100L3.5-SS	3.5		
	SP100L4.5-SS	4.5		
1-1/4	SP125L3-SS	3	.62	3/8-16
	SP125L3.5-SS	3.5		
	SP125L4-SS	4		
	SP125L4.5-SS	4.5		
1.5	SP150L3-SS	3	.62	3/8-16
	SP150L3.5-SS	3.5		
	SP150L4-SS	4		
	SP150L4.5-SS	4.5		
2	SP200L3-SS	3	.62	3/8-16
	SP200L3.5-SS	3.5		
	SP200L4-SS	4		
	SP200L4.5-SS	4.5		
	SP200L5-SS	5		
	SP200L6-SS	6		
3	SP300L5-SS	5	1.25	5/8-11
	SP300L6-SS	6		

1" Long Stainless Socket Head Cap Screw included.



All 2.5" and 4.5" long Threaded Support Pillars are tapped for a set screw enabling a second pillar to be attached as an extension.

SUPPORT COLUMNS FOR DIE CAST DIES

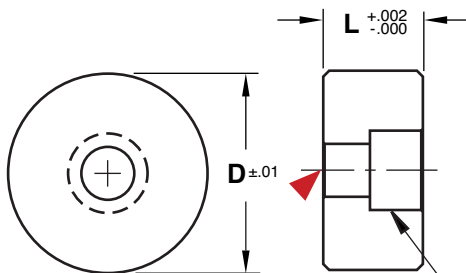


M AISI 4140 **H** 46-50 HRC ▶ CAD insertion point

NOMINAL DIAMETER	D ± .001	CATALOG NUMBER	L +.001 +.002	C
1-1/2	1.496	SPH150L3	3	3/8-16
		SPH150L3.5	3.5	
		SPH150L4	4	
		SPH150L4.5	4.5	
		SPH150L5	5	
2	1.996	SPH200L3	3	3/8-16
		SPH200L3.5	3.5	
		SPH200L4	4	
		SPH200L4.5	4.5	
		SPH200L5	5	

Guided Ejector Bushings sold separately on page B-16.

SUPPORT COLUMN PUCKS



M AISI 1018 ▶ CAD insertion point

D ± .01	L=.75	L=1.00	L=1.50	L=2.00
.750	—	SDB75L1*	—	—
1.000	SDB100L.75	SDB100L1	SDB100L1.5	—
1.500	SDB150L.75	SDB150L1	SDB150L1.5	—
2.000	—	SDB200L1	SDB200L1.5	—
2.500	—	SDB250L1	SDB250L1.5	SDB250L2
3.000	—	SDB300L1	SDB300L1.5	SDB300L2

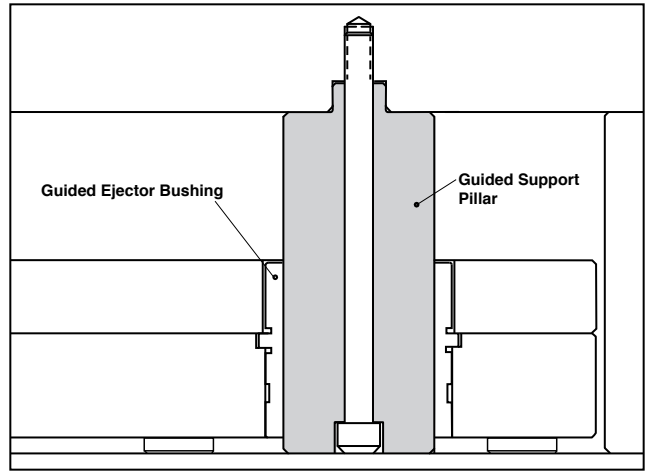
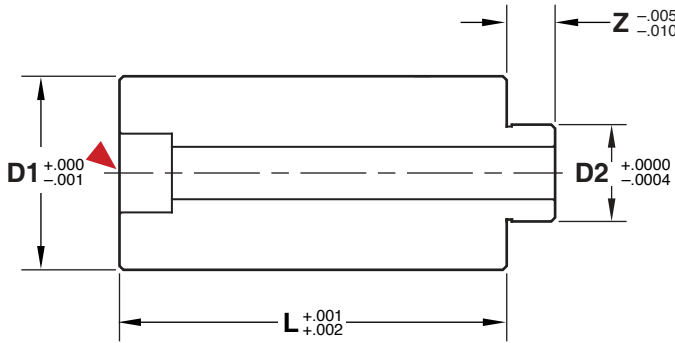
Sized for retaining pin plates in die cast dies.

* L = 1.125 for SDB75L1 Screw included.

Counterbored for 3/8-16 SHCS except for SDB75L1 (1/4-20 SHCS)



GUIDED SUPPORT PILLARS



M AISI 4140 **H** 58-62 HRC **S** Black Oxide ▶ CAD insertion point

NOMINAL DIAMETER	D1 +.000 -.001	D2 +.0000 -.0004	Z -.005 -.010	CATALOG NUMBER	L +.001 +.002	SHCS
3/4	.7495	.4685	.278	GESP75L2.5	2.5	1/4-20 x 2-3/4
				GESP75L3	3	1/4-20 x 3-1/4
				GESP75L3.5	3.5	1/4-20 x 3-3/4
				GESP75L4	4	1/4-20 x 4-1/4
1	.9995	.4998	.309	GESP100L2.5	2.5	5/16-18 x 3
				GESP100L3	3	5/16-18 x 3-1/2
				GESP100L3.5	3.5	5/16-18 x 4
				GESP100L4	4	5/16-18 x 4-1/2
				GESP100L4.5	4.5	5/16-18 x 5
1-1/4	1.2495	.6873	.309	GESP125L3	3	5/16-18 x 3-1/2
				GESP125L3.5	3.5	5/16-18 x 4
				GESP125L4	4	5/16-18 x 4-1/2
				GESP125L4.5	4.5	5/16-18 x 5
				GESP125L5	5	5/16-18 x 5-1/2
1-1/2	1.4995	.7498	.372	GESP150L3.5	3.5	3/8-16 x 4
				GESP150L4	4	3/8-16 x 4-1/2
				GESP150L4.5	4.5	3/8-16 x 5
				GESP150L5	5	3/8-16 x 5-1/2

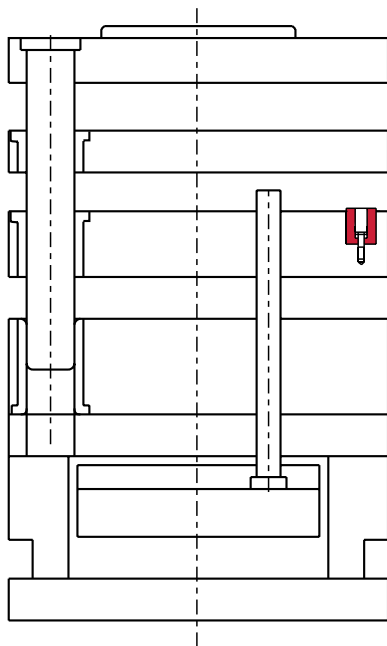
Notes: Includes (1) Socket Head Cap Screw as shown in the chart.
 Guided Ejector Bushings are sold separately on page B-16.

SPRINGS

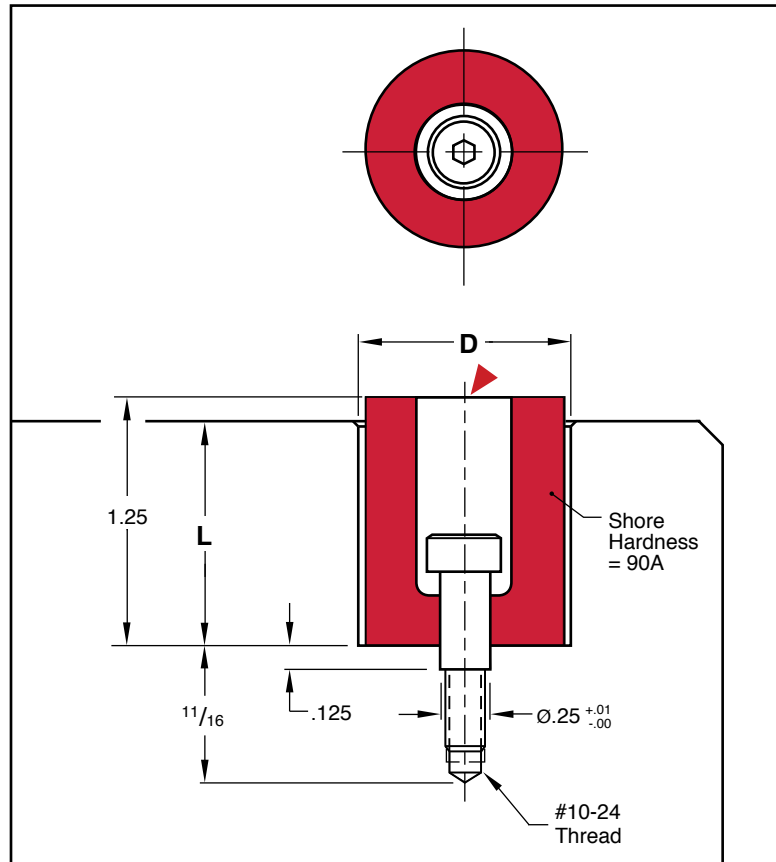
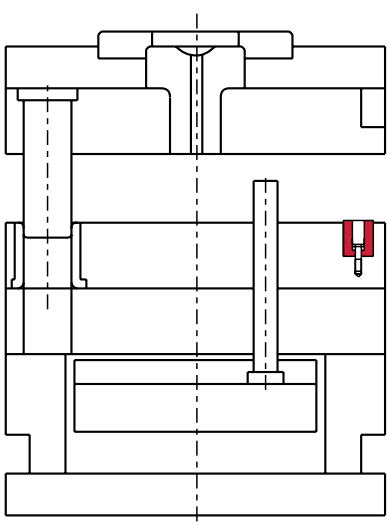
URETHANE SPRINGS



Separate parting lines in sequence



Cushion parting lines



APPLICATION GUIDELINES

- Maximum Mold Temperature: 150°F (65°C)
- Stripper bolt included.

M Solid Urethane

CAD insertion point

DEFLECTION	D	L	APPROXIMATE SPRING PRESSURE
1/8"	1.06	1.12	520 lbs.
1/4"	1.12	1.00	790 lbs.

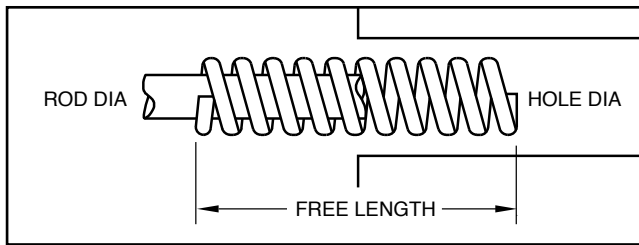
CATALOG NUMBER	DESCRIPTION
US-100	1" Urethane Spring with 1/4ø x 1/2" SBLT



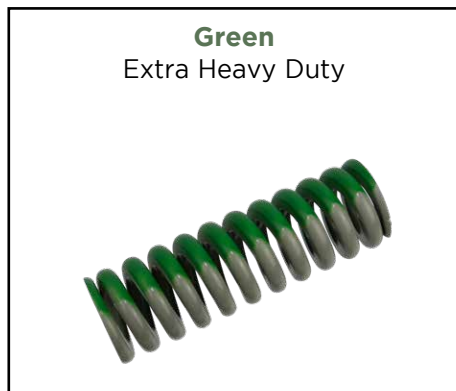
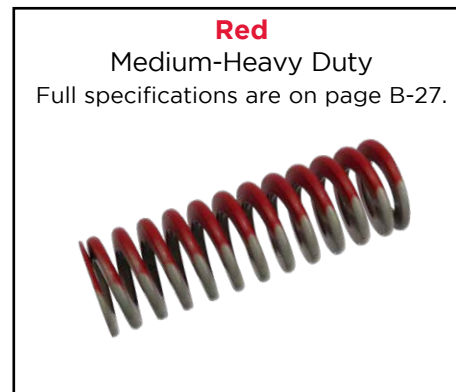
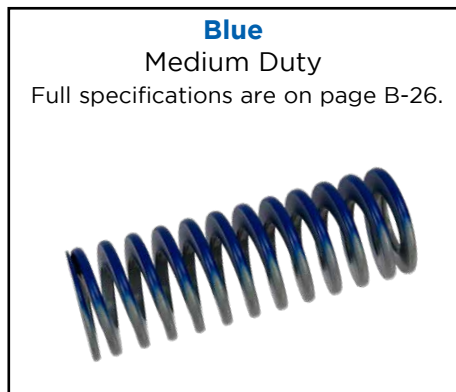
SPRINGS

INCH STANDARD

M Chrome Vanadium Alloy Steel



Progressive's Springs are manufactured from hardened alloy steel and are electrophoretic coated ("E-Coat") to provide full coverage, uniform thickness, and corrosion resistance. The springs are color coded and striped for easy identification.

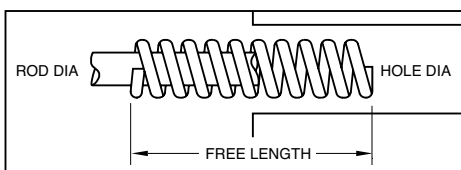


To Order:

1. Choose the color above. Note that Red & Blue Springs have full details and item numbers on the pages noted and are typically in stock.
2. For green and gold springs, determine the Rod Diameter (ID) and Hole Diameter (OD) of the springs.
3. Determine the length and email Customer Service the specifications for pricing and delivery.
4. Other springs are available; contact Customer Service for more information.

SPRINGS

MEDIUM DUTY: INCH STANDARD



Recommended Deflection:
 25% = Optimum Life
 35% = Long Life
 40% = Maximum Operating Deflection

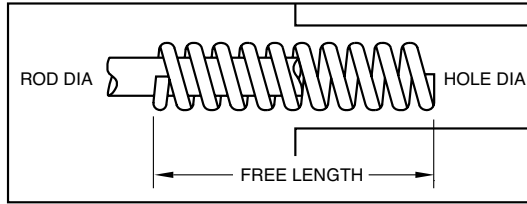
HOLE DIAMETER	ROD DIAMETER	FREE LENGTH	CATALOG NUMBER	APPROX. LOAD AT 1/10" DELFEC. (LBS)	LOAD AT 25% DELFEC. (LBS)	LOAD AT 40% DELFEC. (LBS)	HOLE DIAMETER	ROD DIAMETER	FREE LENGTH	CATALOG NUMBER	APPROX. LOAD AT 1/10" DELFEC. (LBS)	LOAD AT 25% DELFEC. (LBS)	LOAD AT 40% DELFEC. (LBS)		
3/8	3/16	1.00	MS37L1	6.0	15.0	24.0	1	1/2	3.00	MS100L3	17.1	128.3	205.2		
		1.25	MS37L1.25	5.0	15.6	25.0			3.50	MS100L3.5	14.5	126.9	203.0		
		1.50	MS37L1.5	4.2	15.8	25.2			4.00	MS100L4	12.5	125.0	200.0		
		1.75	MS37L1.75	3.7	16.2	25.9			4.50	MS100L4.5	11.0	123.8	198.0		
		2.00	MS37L2	3.1	15.5	24.8			5.00	MS100L5	9.6	120.0	192.0		
		2.50	MS37L2.5	2.6	16.3	26.0			5.50	MS100L5.5	8.8	121.0	193.6		
		3.00	MS37L3	2.1	15.8	25.2			6.00	MS100L6	8.0	120.0	192.0		
WIRE .039 X .070		12.00	MS37L12	0.6	18.0	28.8			7.00	MS100L7	7.2	126.0	201.6		
		1.00	MS50L1	11.0	27.5	44.0			8.00	MS100L8	6.0	120.0	192.0		
		1.25	MS50L1.25	8.2	25.6	41.0			12.00	MS100L12	4.0	120.0	192.0		
		1.50	MS50L1.5	6.8	25.5	40.8			1-1/4	5/8	1.50	MS125L1.5	49.6	186.0	297.6
		1.75	MS50L1.75	6.0	26.3	42.0					1.75	MS125L1.75	40.6	177.6	284.2
		2.00	MS50L2	5.5	27.5	44.0					2.00	MS125L2	37.6	188.0	300.8
		2.50	MS50L2.5	4.5	28.1	45.0					2.50	MS125L2.5	28.8	180.0	288.0
		3.00	MS50L3	3.5	26.3	42.0	3.00	MS125L3			24.0	180.0	288.0		
		3.50	MS50L3.5	3.0	26.3	42.0	3.50	MS125L3.5			20.0	175.0	280.0		
		4.50	MS50L4.5	2.3	25.9	41.4	4.00	MS125L4			17.6	176.0	281.6		
5.50	MS50L5.5	2.0	27.5	44.0	4.50	MS125L4.5	16.0	180.0			288.0				
6.50	MS50L6.5	1.4	22.8	36.4	5.00	MS125L5	14.3	178.8			286.0				
7.50	MS50L7.5	1.2	22.5	36.0	5.50	MS125L5.5	12.8	176.0			281.6				
12.00	MS50L12	0.7	21.0	33.6	6.00	MS125L6	12.0	180.0	288.0						
WIRE .052 X .093	9/32	1.00	MS62L1	16.4	41.0	65.6	7.00	MS125L7	10.4	182.0	291.2				
		1.25	MS62L1.25	12.4	38.8	62.0	8.00	MS125L8	8.8	176.0	281.6				
		1.50	MS62L1.5	10.8	40.5	64.8	10.00	MS125L10	7.2	180.0	288.0				
		1.75	MS62L1.75	9.6	42.0	67.2	12.00	MS125L12	6.0	180.0	288.0				
		2.00	MS62L2	8.6	43.0	68.8	WIRE .115 X .285	3/4	2.00	MS150L2	53.0	265.0	424.0		
		2.50	MS62L2.5	6.5	40.6	65.0			2.50	MS150L2.5	42.7	266.9	427.0		
		3.00	MS62L3	5.8	43.5	69.6			3.00	MS150L3	36.0	270.0	432.0		
		3.50	MS62L3.5	5.0	43.8	70.0			3.50	MS150L3.5	30.0	262.5	420.0		
		4.00	MS62L4	4.4	44.0	70.4			4.00	MS150L4	24.9	249.0	398.4		
		4.00	MS62L4	4.4	44.0	70.4			4.50	MS150L4.5	23.0	258.8	414.0		
12.00	MS62L12	1.5	45.0	72.0	5.00	MS150L5			21.0	262.5	420.0				
WIRE .069 X .109	11/32	1.00	MS75L1	32.0	80.0	128.0			5.50	MS150L5.5	18.5	254.4	407.0		
		1.25	MS75L1.25	25.6	80.0	128.0			6.00	MS150L6	17.0	255.0	408.0		
		1.50	MS75L1.5	20.0	75.0	120.0			7.00	MS150L7	15.3	267.8	428.4		
		1.75	MS75L1.75	17.6	77.0	123.2	8.00	MS150L8	13.2	264.0	422.4				
		2.00	MS75L2	15.0	75.0	120.0	10.00	MS150L10	10.6	265.0	424.0				
		2.50	MS75L2.5	12.0	75.0	120.0	12.00	MS150L12	8.5	255.0	408.0				
		3.00	MS75L3	10.1	75.8	121.2	WIRE .135 X .345	1	2.50	MS200L2.5	100.0	625.0	1000.0		
		3.50	MS75L3.5	8.3	72.6	116.2			3.00	MS200L3	83.0	622.5	996.0		
		4.00	MS75L4	7.5	75.0	120.0			3.50	MS200L3.5	67.7	592.4	947.8		
		4.50	MS75L4.5	6.4	72.0	115.2			4.00	MS200L4	60.0	600.0	960.0		
5.00	MS75L5	6.0	75.0	120.0	4.50	MS200L4.5			53.0	596.3	954.0				
5.50	MS75L5.5	5.5	75.6	121.0	5.00	MS200L5			47.0	587.5	940.0				
6.00	MS75L6	5.0	75.0	120.0	5.50	MS200L5.5			40.5	556.9	891.0				
6.50	MS75L6.5	4.7	76.4	122.2	6.00	MS200L6			39.0	585.0	936.0				
7.50	MS75L7.5	3.8	71.3	114.0	7.00	MS200L7			31.2	546.0	873.6				
12.00	MS75L12	2.4	72.0	115.2	8.00	MS200L8			28.5	570.0	912.0				
WIRE .075 X .165	3/8	1.00	MS75L1	32.0	80.0	128.0	10.00	MS200L10	21.6	540.0	864.0				
		1.25	MS75L1.25	25.6	80.0	128.0	12.00	MS200L12	18.5	555.0	888.0				
		1.50	MS75L1.5	20.0	75.0	120.0	WIRE .195 X .468	2	1						
		1.75	MS75L1.75	17.6	77.0	123.2									
		2.00	MS75L2	15.0	75.0	120.0									
		2.50	MS75L2.5	12.0	75.0	120.0									
		3.00	MS75L3	10.1	75.8	121.2									
3.50	MS75L3.5	8.3	72.6	116.2											
4.00	MS75L4	7.5	75.0	120.0											
WIRE .039 X .070	3/8	1.00	MS62L1	16.4	41.0	65.6	1	1/2	3.00	MS100L3	17.1	128.3	205.2		
		1.25	MS62L1.25	12.4	38.8	62.0			3.50	MS100L3.5	14.5	126.9	203.0		
		1.50	MS62L1.5	10.8	40.5	64.8			4.00	MS100L4	12.5	125.0	200.0		
		1.75	MS62L1.75	9.6	42.0	67.2			4.50	MS100L4.5	11.0	123.8	198.0		
		2.00	MS62L2	8.6	43.0	68.8			5.00	MS100L5	9.6	120.0	192.0		
		2.50	MS62L2.5	6.5	40.6	65.0			5.50	MS100L5.5	8.8	121.0	193.6		
		3.00	MS62L3	5.8	43.5	69.6			6.00	MS100L6	8.0	120.0	192.0		
WIRE .069 X .109	11/32	3.50	MS62L3.5	5.0	43.8	70.0	7.00	MS100L7	7.2	126.0	201.6				
		4.00	MS62L4	4.4	44.0	70.4	8.00	MS100L8	6.0	120.0	192.0				
		4.00	MS62L4	4.4	44.0	70.4	12.00	MS100L12	4.0	120.0	192.0				
		12.00	MS62L12	1.5	45.0	72.0	1.50	MS125L1.5	49.6	186.0	297.6				
		WIRE .052 X .093	9/32	1.00	MS50L1	11.0	27.5	44.0	1.75	MS125L1.75	40.6	177.6	284.2		
				1.25	MS50L1.25	8.2	25.6	41.0	2.00	MS125L2	37.6	188.0	300.8		
				1.50	MS50L1.5	6.8	25.5	40.8	2.50	MS125L2.5	28.8	180.0	288.0		
1.75	MS50L1.75			6.0	26.3	42.0	3.00	MS125L3	24.0	180.0	288.0				
2.00	MS50L2			5.5	27.5	44.0	3.50	MS125L3.5	20.0	175.0	280.0				
2.50	MS50L2.5			4.5	28.1	45.0	4.00	MS125L4	17.6	176.0	281.6				
3.00	MS50L3			3.5	26.3	42.0	4.50	MS125L4.5	16.0	180.0	288.0				
3.50	MS50L3.5			3.0	26.3	42.0	5.00	MS125L5	14.3	178.8	286.0				
4.50	MS50L4.5			2.3	25.9	41.4	5.50	MS125L5.5	12.8	176.0	281.6				
5.50	MS50L5.5			2.0	27.5	44.0	6.00	MS125L6	12.0	180.0	288.0				
WIRE .029 X .070	3/16	1.00	MS37L1	6.0	15.0	24.0	7.00	MS125L7	10.4	182.0	291.2				
		1.25	MS37L1.25	5.0	15.6	25.0	8.00	MS125L8	8.8	176.0	281.6				
		1.50	MS37L1.5	4.2	15.8	25.2	10.00	MS125L10	7.2	180.0	288.0				
		1.75	MS37L1.75	3.7	16.2	25.9	12.00	MS125L12	6.0	180.0	288.0				
		2.00	MS37L2	3.1	15.5	24.8	WIRE .115 X .285	3/4	2.00	MS150L2	53.0	265.0	424.0		
		2.50	MS37L2.5	2.6	16.3	26.0			2.50	MS150L2.5	42.7	266.9	427.0		
		3.00	MS37L3	2.1	15.8	25.2			3.00	MS150L3	36.0	270.0	432.0		
		12.00	MS37L12	0.6	18.0	28.8			3.50	MS150L3.5	30.0	262.5	420.0		
		WIRE .052 X .093	9/32	1.00	MS50L1	11.0			27.5	44.0	4.00	MS150L4	24.9	249.0	398.4
				1.25	MS50L1.25	8.2			25.6	41.0	4.50	MS150L4.5	23.0	258.8	414.0
1.50	MS50L1.5			6.8	25.5	40.8			5.00	MS150L5	21.0	262.5	420.0		
1.75	MS50L1.75			6.0	26.3	42.0			5.50	MS150L5.5	18.5	254.4	407.0		
2.00	MS50L2			5.5	27.5	44.0			6.00	MS150L6	17.0	255.0	408.0		
2.50	MS50L2.5			4.5	28.1	45.0			7.00	MS150L7	15.3	267.8	428.4		
3.00	MS50L3			3.5	26.3	42.0	8.00	MS150L8	13.2	264.0	422.4				
3.50	MS50L3.5			3.0	26.3	42.0	10.00	MS150L10	10.6	265.0	424.0				
4.50	MS50L4.5			2.3	25.9	41.4	12.00	MS150L12	8.5	255.0	408.0				
5.50	MS50L5.5			2.0	27.5	44.0	WIRE .135 X .345	1	2.50	MS200L2.5	100.0	625.0	1000.0		
6.50	MS50L6.5	1.4	22.8	36.4	3.00	MS200L3			83.0	622.5	996.0				
7.50	MS50L7.5	1.2	22.5	36.0	3.50	MS200L3.5			67.7	592.4	947.8				
12.00	MS50L12	0.7	21.0	33.6	4.00	MS200L4			60.0	600.0	960.0				
WIRE .069 X .109	11/32	1.00	MS62L1	16.4	41.0	65.6			4.50	MS200L4.5	53.0	596.3	954.0		
		1.25	MS62L1.25	12.4	38.8	62.0			5.00	MS200L5	47.0	587.5	940.0		
		1.50	MS62L1.5	10.8	40.5	64.8			5.50	MS200L5.5	40.5	556.9	891.0		



SPRINGS

MEDIUM-HEAVY DUTY: INCH STANDARD

Recommended Deflection:
 20% = Optimum Life
 25% = Long Life
 30% = Maximum Operating Deflection



HOLE DIAMETER	ROD DIAMETER	FREE LENGTH	CATALOG NUMBER	APPROX. LOAD AT 1/10" DELFEC. (LBS)	LOAD AT 20% DELFEC. (LBS)	LOAD AT 30% DELFEC. (LBS)
3/8	3/16	1.00	HS37L1	8.4	16.8	25.2
		1.25	HS37L1.25	7.3	18.3	27.4
		1.50	HS37L1.5	6.7	20.1	30.2
		1.75	HS37L1.75	5.8	20.3	30.5
		2.00	HS37L2	5.0	20.0	30.0
		2.50	HS37L2.5	3.7	18.5	27.8
		3.00	HS37L3	3.0	18.0	27.0
		12.00	HS37L12	0.8	19.2	28.8
1/2	9/32	1.00	HS50L1	15.5	31.0	46.5
		1.25	HS50L1.25	12.2	30.5	45.8
		1.50	HS50L1.5	9.8	29.4	44.1
		1.75	HS50L1.75	8.5	29.8	44.6
		2.00	HS50L2	7.5	30.0	45.0
		2.50	HS50L2.5	6.0	30.0	45.0
		3.00	HS50L3	5.1	30.6	45.9
		12.00	HS50L12	1.1	26.4	39.6
5/8	11/32	1.00	HS62L1	30.0	60.0	90.0
		1.25	HS62L1.25	21.5	53.8	80.6
		1.50	HS62L1.5	19.0	57.0	85.5
		1.75	HS62L1.75	16.8	58.8	88.2
		2.00	HS62L2	15.5	62.0	93.0
		2.50	HS62L2.5	11.5	57.5	86.3
		3.00	HS62L3	10.0	60.0	90.0
		12.00	HS62L12	2.6	62.4	93.6
3/4	3/8	1.00	HS75L1	50.0	100.0	150.0
		1.25	HS75L1.25	38.0	95.0	142.5
		1.50	HS75L1.5	31.0	93.0	139.5
		1.75	HS75L1.75	27.0	94.5	141.8
		2.00	HS75L2	24.0	96.0	144.0
		2.50	HS75L2.5	18.8	94.0	141.0
		3.00	HS75L3	14.9	89.4	134.1
		3.50	HS75L3.5	12.8	89.6	134.4
		4.00	HS75L4	11.0	88.0	132.0
		4.50	HS75L4.5	10.0	90.0	135.0
		5.00	HS75L5	9.0	90.0	135.0
		12.00	HS75L12	3.5	84.0	126.0
1	1/2	1.00	HS100L1	82.7	165.4	248.1
		1.25	HS100L1.25	65.3	163.3	244.9
		1.50	HS100L1.5	53.8	161.4	242.1
		1.75	HS100L1.75	46.1	161.4	242.0
		2.00	HS100L2	40.0	160.0	240.0
		2.50	HS100L2.5	32.2	161.0	241.5

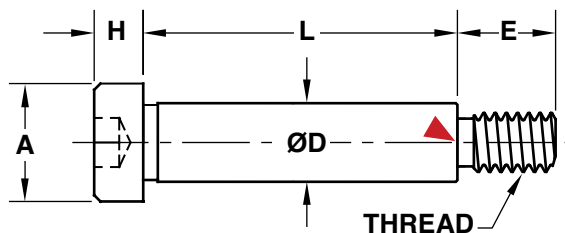
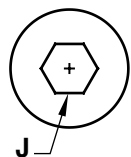
HOLE DIAMETER	ROD DIAMETER	FREE LENGTH	CATALOG NUMBER	APPROX. LOAD AT 1/10" DELFEC. (LBS)	LOAD AT 20% DELFEC. (LBS)	LOAD AT 30% DELFEC. (LBS)		
1	1/2	3.00	HS100L3	26.7	160.2	240.3		
		3.50	HS100L3.5	22.9	160.3	240.5		
		4.00	HS100L4	20.2	161.6	242.4		
		4.50	HS100L4.5	17.8	160.2	240.3		
		5.00	HS100L5	15.7	157.0	235.5		
		5.50	HS100L5.5	13.7	150.7	226.1		
		6.00	HS100L6	12.5	150.0	225.0		
		7.00	HS100L7	10.9	152.6	228.9		
		8.00	HS100L8	9.6	153.6	230.4		
		12.00	HS100L12	6.5	156.0	234.0		
		1-1/4	5/8	1.50	HS125L1.5	114.4	343.2	514.8
				1.75	HS125L1.75	100.8	352.8	529.2
2.00	HS125L2			83.8	335.2	502.8		
2.50	HS125L2.5			62.4	312.0	468.0		
3.00	HS125L3			51.2	307.2	460.8		
3.50	HS125L3.5			44.0	308.0	462.0		
4.00	HS125L4			38.1	304.8	457.2		
4.50	HS125L4.5			32.9	296.1	444.2		
5.00	HS125L5			30.0	300.0	450.0		
5.50	HS125L5.5			26.4	290.4	435.6		
6.00	HS125L6			25.0	300.0	450.0		
7.00	HS125L7			21.0	294.0	441.0		
8.00	HS125L8	18.4	294.4	441.6				
10.00	HS125L10	14.5	290.0	435.0				
12.00	HS125L12	12.4	297.6	446.4				
1-1/2	3/4	2.00	HS150L2	103.0	412.0	618.0		
		2.50	HS150L2.5	81.2	406.0	609.0		
		3.00	HS150L3	62.4	374.4	561.6		
		3.50	HS150L3.5	54.0	378.0	567.0		
		4.00	HS150L4	46.5	372.0	558.0		
		4.50	HS150L4.5	41.0	369.0	553.5		
		5.00	HS150L5	36.8	368.0	552.0		
		5.50	HS150L5.5	33.0	363.0	544.5		
		6.00	HS150L6	29.5	354.0	531.0		
		7.00	HS150L7	25.5	357.0	535.5		
		8.00	HS150L8	22.0	352.0	528.0		
		10.00	HS150L10	17.6	352.0	528.0		
12.00	HS150L12	14.4	345.6	518.4				
2	1	2.50	HS200L2.5	118.4	592.0	888.0		
		3.00	HS200L3	93.0	558.0	837.0		
		3.50	HS200L3.5	78.2	547.4	821.1		
		4.00	HS200L4	66.4	531.2	796.8		
		4.50	HS200L4.5	60.0	540.0	810.0		
		5.00	HS200L5	53.4	534.0	801.0		
		5.50	HS200L5.5	49.0	539.0	808.5		
		6.00	HS200L6	45.0	540.0	810.0		
		7.00	HS200L7	37.4	523.6	785.4		
		8.00	HS200L8	33.0	528.0	792.0		
		10.00	HS200L10	26.0	520.0	780.0		
		12.00	HS200L12	21.5	516.0	774.0		

Free Length	Tolerance
1"-2" Long	+0.093/-0
2-1/2"-4" Long	+0.126/-0
5"-7" Long	+0.189/-0

Free Length	Tolerance
8"-9" Long	+0.252/-0
10"-12" Long	+0.375/-0

Note: All pressure ratings are approximate and are subject to +10% over amounts shown for deflection.

STRIPPER BOLTS



M SCM440 **H** 42-48 HRC

CAD insertion point

D +.000 -.001	L ±.001	CATALOG NUMBER	J	A	H	E	THREAD 3A
.249	1	SBLT25L1	1/8	.37	.18	.37	#10-24
	1.25	SBLT25L1.25					
	1.5	SBLT25L1.5					
.311	1	SBLT31L1	5/32	.43	.21	.43	1/4-20
	1.25	SBLT31L1.25					
	1.5	SBLT31L1.5					
	1.75	SBLT31L1.75					
.374	2	SBLT31L2	3/16	.56	.25	.50	5/16-18
	1	SBLT37L1					
	1.25	SBLT37L1.25					
	1.5	SBLT37L1.5					
	1.75	SBLT37L1.75					
	2	SBLT37L2					
	2.25	SBLT37L2.25					
	2.5	SBLT37L2.5					
	2.75	SBLT37L2.75					
	3	SBLT37L3					
	3.25	SBLT37L3.25					
	3.5	SBLT37L3.5					
	3.75	SBLT37L3.75					
.499	4	SBLT37L4	1/4	.75	.31	.62	3/8-16
	4.25	SBLT37L4.25					
	4.5	SBLT37L4.5					
	1	SBLT50L1					
	1.25	SBLT50L1.25					
	1.5	SBLT50L1.5					
	1.75	SBLT50L1.75					
	2	SBLT50L2					
	2.25	SBLT50L2.25					
	2.5	SBLT50L2.5					
	2.75	SBLT50L2.75					
	3	SBLT50L3					
	3.25	SBLT50L3.25					
	3.5	SBLT50L3.5					
	3.75	SBLT50L3.75					
4	SBLT50L4						
4.25	SBLT50L4.25						
4.5	SBLT50L4.5						
4.75	SBLT50L4.75						
5	SBLT50L5						
5.5	SBLT50L5.5						
6	SBLT50L6						
7	SBLT50L7						

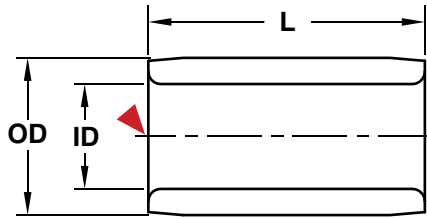
D +.000 -.001	L ±.001	CATALOG NUMBER	J	A	H	E	THREAD 3A
.624	1.25	SBLT62L1.25	5/16	.87	.37	.75	1/2-13
	1.5	SBLT62L1.5					
	1.75	SBLT62L1.75					
	2	SBLT62L2					
	2.25	SBLT62L2.25					
	2.5	SBLT62L2.5					
	2.75	SBLT62L2.75					
	3	SBLT62L3					
	3.25	SBLT62L3.25					
	3.5	SBLT62L3.5					
	3.75	SBLT62L3.75					
	4	SBLT62L4					
	4.25	SBLT62L4.25					
	4.5	SBLT62L4.5					
4.75	SBLT62L4.75						
.749	5	SBLT62L5	3/8	1.00	.50	.87	5/8-11
	5.5	SBLT62L5.5					
	6	SBLT62L6					
	7	SBLT62L7					
	1.5	SBLT75L1.5					
	1.75	SBLT75L1.75					
	2	SBLT75L2					
	2.25	SBLT75L2.25					
	2.5	SBLT75L2.5					
	2.75	SBLT75L2.75					
	3	SBLT75L3					
	3.25	SBLT75L3.25					
	3.5	SBLT75L3.5					
	3.75	SBLT75L3.75					
4	SBLT75L4						
4.25	SBLT75L4.25						
4.5	SBLT75L4.5						
4.75	SBLT75L4.75						
5	SBLT75L5						
5.5	SBLT75L5.5						
6	SBLT75L6						
7	SBLT75L7						
8	SBLT75L8						

APPLICATION GUIDELINES

- Precise diameters exceed industry standards.
- Tighter tolerances for uniform plate-stop positioning.
- Stripper Bolt Bushings sold separately on page B-29.



STRIPPER BOLT BUSHINGS

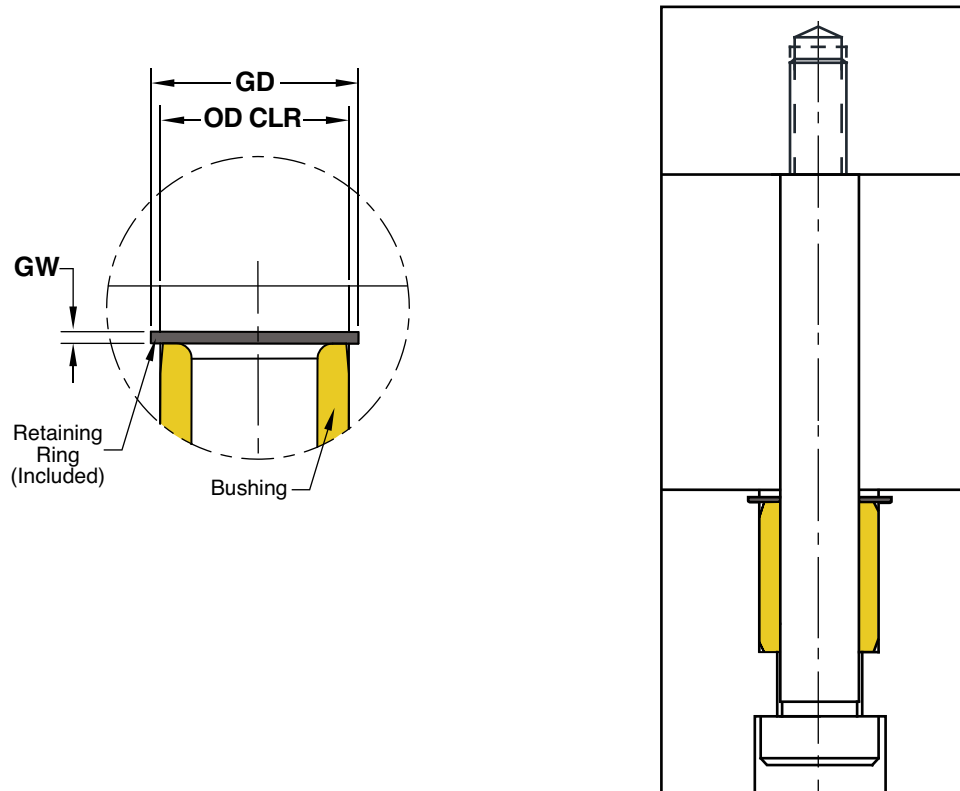


M SAE841 Bronze

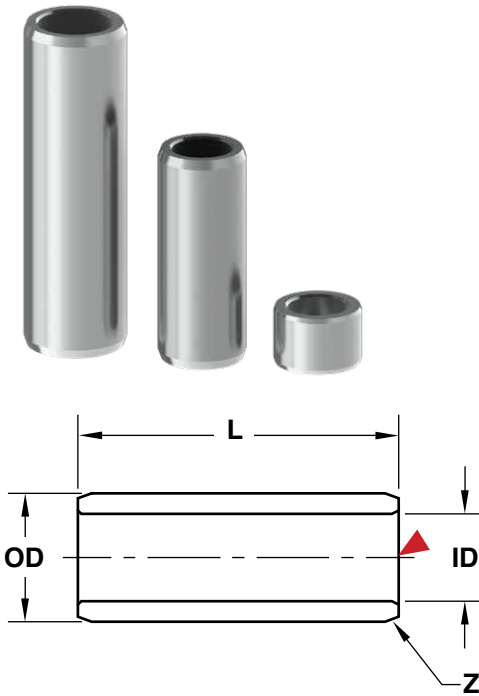
▶ CAD insertion point

CATALOG NUMBER	ID +.000 -.001	OD +.000 -.001	L ±.005	GD +.005 -.000	GW +.003 -.000	OD CLR +.005 -.000
SBB25L.50	.251	.439	.500	.530	.029	.448
SBB31L.62	.312	.627	.625	.665	.039	.635
SBB37L.75	.376	.627	.750	.665	.039	.635
SBB50L1.00	.502	.753	1.000	.825	.046	.780
SBB63L1.50	.627	.878	1.500	1.000	.046	.950
SBB75L1.50	.752	1.003	1.500	1.091	.046	1.040

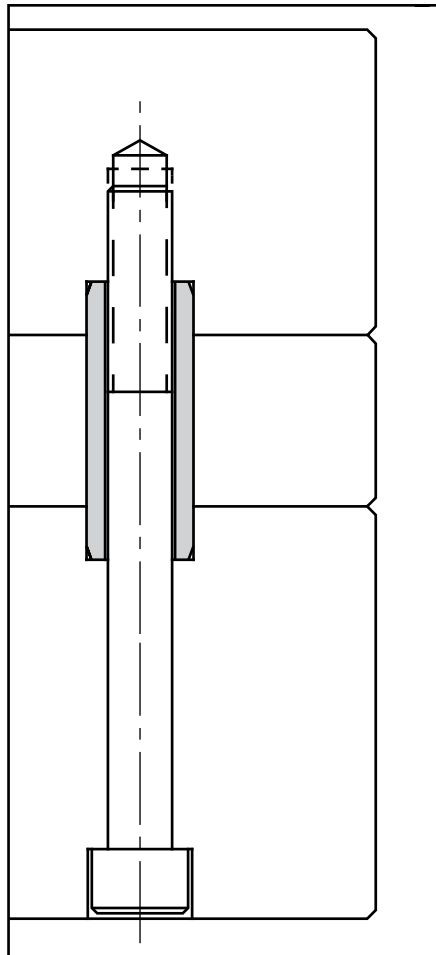
Replacement Retaining Rings are available. To order, specify the prefix of "RRB" before the ID.
Ex. RRB25 for a 1/4 ID ring. Note: SBB31L.62 utilizes an RRB37.



TUBULAR DOWELS



CAD insertion point



Inch Standard

M Carbon Steel **H** 55 HRC

CATALOG NUMBER	OD ±.0001	ID +.01 -.00	L +.00 -.02	Z CHAMFER
TD37L.37	.3752	.260	.375	.04 x 20°
TD37L.87			.875	.04 x 20°
TD62L.50	.6252	.385	.500	.04 x 20°
TD62L1.37			1.375	.08 x 20°
TD62L1.87			1.875	.08 x 20°
TD62L2.37			2.375	.08 x 20°
TD75L.37	.7502	.510	.375	.04 x 20°
TD75L.50			.500	.04 x 20°
TD75L1.37			1.375	.08 x 20°
TD75L1.87			1.875	.08 x 20°
TD75L2.37			2.375	.08 x 20°
TD75L2.87			2.875	.08 x 20°
TD75L3.37			3.375	.08 x 20°
TD75L3.87	3.875	.08 x 20°		
TD87L.50	.8752	.635	.500	.04 x 20°
TD87L2.37			2.375	.08 x 20°
TD87L2.87			2.875	.08 x 20°

Metric Standard

M Carbon Steel **H** 55 HRC

CATALOG NUMBER	OD ±.003	ID +.25 -.00	L +.00 -.50	Z CHAMFER
TDM10L20	10	6.2	20	1 x 20°
TDM10L30			30	1 x 20°
TDM14L30	14	8.5	30	1 x 20°
TDM14L40			40	2 x 20°
TDM14L50			50	2 x 20°
TDM14L60			60	2 x 20°
TDM14L70			70	2 x 20°
TDM18L40	18	10.5	40	1 x 20°
TDM18L60			60	1 x 20°
TDM18L80			80	2 x 20°
TDM18L100			100	2 x 20°
TDM24L60	24	13	60	1 x 20°
TDM24L80			80	2 x 20°
TDM24L100			100	2 x 20°

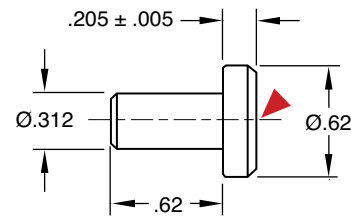


STOP PINS

Dowel Type

M Pre-Hard Steel **H** Black Oxide

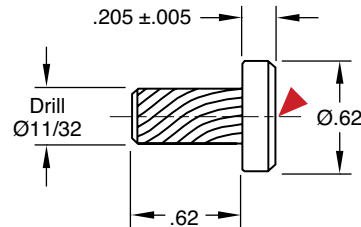
CATALOG NUMBER	DESCRIPTION
STP-1	Stop Pins



Self-Tapping

H AISI 4037 **H** 40-44 HRC **S** Black Oxide

CATALOG NUMBER	DESCRIPTION
STP-2	Self-Tapping Stop Pins



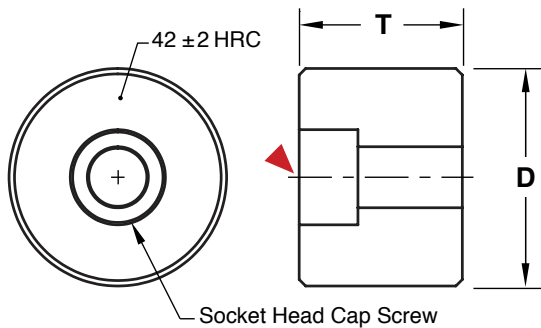
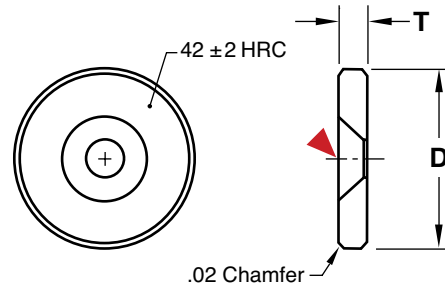
▶ CAD insertion point

STOP DISCS

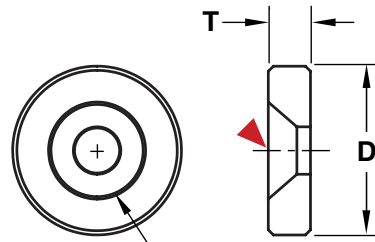
M 4140 **H** 40-44 HRC **S** Black Oxide

CATALOG NUMBER	D +.000 -.015	T +.003 +.005	FLAT HEAD COUNTERBORE
SD68	.687	.188	#10-24
SD100	1.000	.188	1/4-20
SD118	1.187	.188	1/4-20
SD168	1.687	.251	5/16-18

1/2" long Flat Head Screw included.



Socket Head Cap Screw



Flat Head Cap Screw (SPC25X100)

SPACERS



M 4140 **H** 40-44 HRC **S** Black Oxide

CATALOG NUMBER	D +.000 -.015	T +.002 +.000	SCREW SIZE (INCLUDED)
SPC25X100	1.000	.250	1/4-20 x 5/8 Flat Head
SPC37X100	1.000	.375	1/4-20 x 1/2 Socket Head
SPC50X100	1.000	.500	1/4-20 x 5/8 Socket Head
SPC50X168	1.688	.500	1/4-20 x 5/8 Socket Head
SPC62X100	1.000	.625	1/4-20 x 3/4 Socket Head
SPC75X100	1.000	.750	1/4-20 x 7/8 Socket Head
SPC100X100	1.000	1.000	1/4-20 x 1-1/8 Socket Head
SPC100X168	1.688	1.000	1/4-20 x 1-1/8 Socket Head

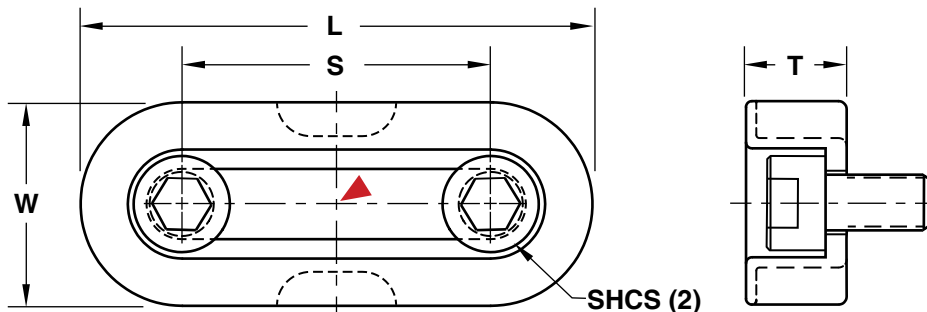
▶ CAD insertion point

SAFETY STRAPS



APPLICATION GUIDELINES

- Secures mold parting lines for transportation, mold setting, and storage.
- Breakaway feature in center of the Safety Strap is engineered to break slightly before the bolts would shear.
- If unintentionally left on the mold in the press, the Safety Strap will be obvious to the operator that it is broken and can easily be replaced. Other straps shear the bolts, which cannot be removed with the mold in the press, creating an unsafe condition when the mold is later removed from the machine.
- Progressive Safety Straps can replace others' mold straps.
- Strength Ratings have a safety factor of two.
- Powder coated OSHA yellow.

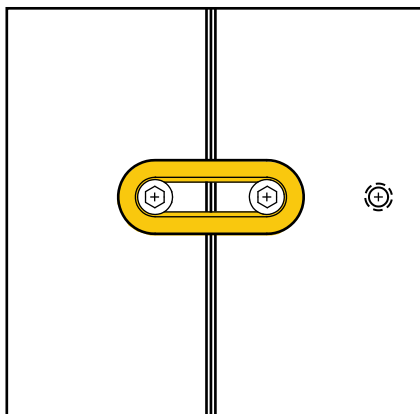


M 1010 **H** 85 Brinell

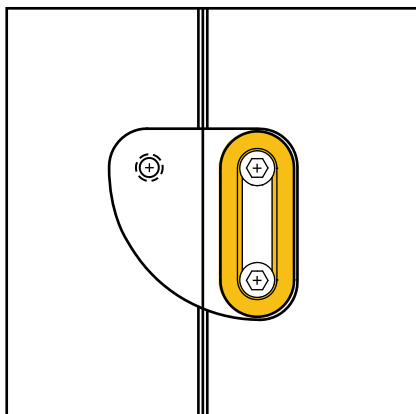
CATALOG NUMBER	L	W	T	S	SHCS	STRENGTH RATING (LBS)
SAFT-88	1.62	.75	.37	.88	1/4-20 x 1/2	1,000
SAFT-150	2.50	1.00	.50	1.50	5/16-18 x 5/8	1,500
SAFT-200	3.37	1.37	.75	2.00	1/2-13 x 1	3,000

▶ CAD insertion point

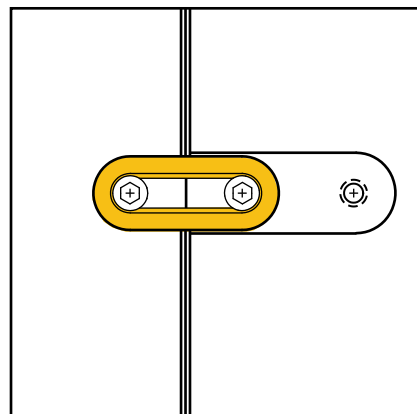
Holo-Krome® screws included.



Surface Mount



Swing Mount



Sliding Mount

EXAMPLE MOLD SIZES	STRAP PART NUMBER
UNDER 1,000 LBS (UNIT DIES AND 8X8 AND SMALLER)	SAFT-88
UNDER 1,500 LBS (EX. 15 7/8 x 26)	SAFT-150
UNDER 3,000 LBS (EX. 19 1/2 x 35 1/2)	SAFT-200

The above is for one Strap per mold, although additional straps can be used for larger molds.

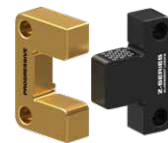
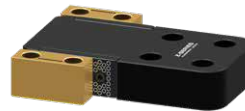
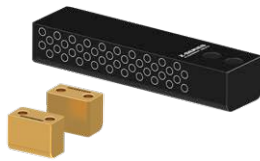
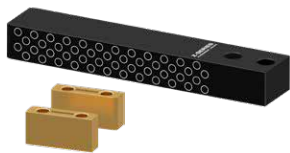
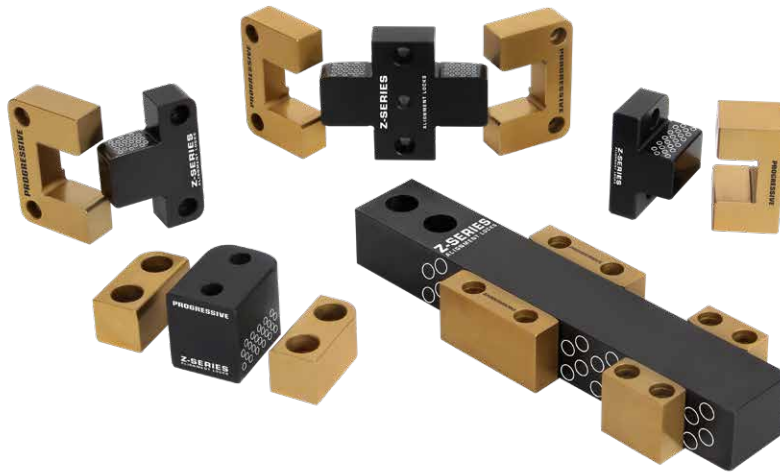


Unlike other mold straps, Progressive's Safety Straps have an engineered break point to avoid bolt shearing when left on the tool in the press.

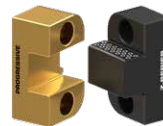


ALIGNMENT LOCKS

SECTION C



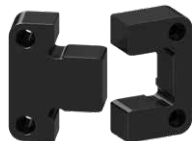
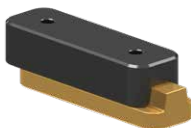
Bar Locks	Bar Locks: Top Machining/X	Bar Locks: Inserted	Side Locks
Prefix: BLB, BLG	Prefix: BLBT, BLGT, BLBX	Prefix: BLN, BLS	Prefix: SL, SLC, SLM
Page: C-4 & C-5	Page: C-6 & C-7	Page: C-9	Page: C-10



X-Style Side Locks	Top Locks: Internal	Top Locks	Guide Locks
Prefix: SLX	Prefix: TL, TLM	Prefix: TL, TLM	Prefix: GL, GLM
Page: C-11	Page: C-12	Page: C-13	Page: C-14



Radial Springs	Cavity Interlocks (Flat/Round)	Taper Locks: Counterbored	Taper Locks & Plates
Prefix: RS	Prefix: CF, CFM, CRS, CRSM	Prefix: TLC	Prefix: MTL, FTL, TLP
Page: C-15	Page: C-16 & C-17	Page: C-18	Page: C-19



Rectangular Taper Bar Locks	Side Lock: Die Cast	Needle Bearing Locks	Side Locks: Steel/Gr. Plugged
Prefix: MTBL, FTBL	Prefix: SL Suffix: -BN	Prefix: SLR, SLRM, TLR	Prefix: SLPM, SLS, SLMS
Page: C-20	Page: C-21	Page: C-22 & C-23	Page: C-24 & C-25



ALIGNMENT LOCKS PERFORMANCE TESTING

Progressive Components regularly tests products through independent testing facilities nationwide.

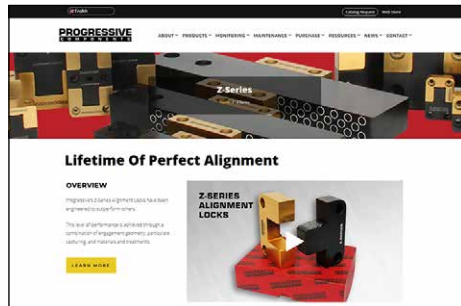
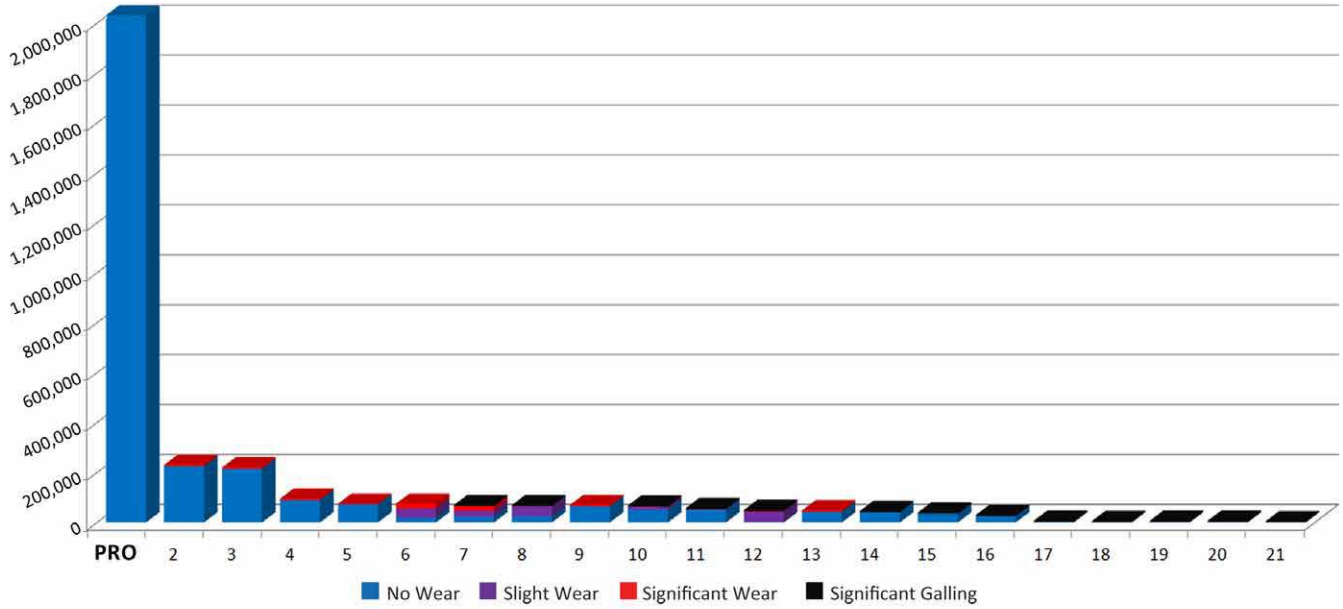
Before launching of the Z-Series® Alignment Locks, Progressive contracted Element Materials Technology to provide a thorough mold lock Performance Evaluation:

“Element Materials Technology has conducted independent life cycle testing of mold interlocks since 1999. The processes with fixtures and cycling were established to simulate use in the molding environment, but more severe loads were used to accelerate the failures at 4400 lbs of pressure. The locks tested have been from Progressive as well as other standard lock distributors in the US and Asia, plus several additional material and treatment combinations were tested for comparison.”

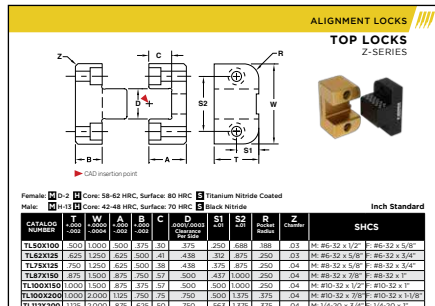
It was determined that the Progressive Components Z-Series Alignment Locks exceeded the 2-million cycle mark, and still displayed no measurable signs of wear of any type.

“During the past few years, over 21 different tests were performed with the purpose of cycling until failure occurred. At no time during our tests over the years have we seen cycle performance at the level of this new design, represented as PRO in the chart below.”

With the industry’s widest selection of sizes in stock and competitively priced, specifying alignment locks from Progressive Components means your molds will have unmatched protection from damage and downtime.



Learn more at procomps.com/z-series.



All catalog pages are online for forwarding to suppliers, customers, etc.

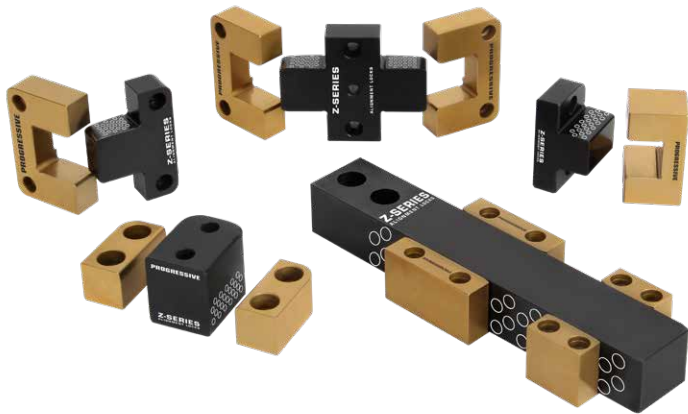
ONLINE DATA

Sample ID	Material	Coating	Core Hardness	Material	Coating	Core Hardness	Lube	Cycles	Figure
PRO Z-Series	D-2	TiN	58-62 HRC	H-13 Nitro Carburized	42-48 HRC	Serol INT/300		2000000	3
PCS Top Lock	A-2	Black Oxide	58-60 HRC	A-2 Black Oxide	58-60 HRC	PCS Nano		225000	4
DMS	S-7	TiN	58-56 HRC	O-6 Black Oxide	58-60 HRC	INT/300		215000	5
Sof	S-7	TiN	50-52 HRC	O-6 Black Oxide	50-52 HRC	Serol INT/300		150000	6
PCS Label	A-2	TiN	58-62 HRC	H-13 Malonite	40-44 HRC	Lithium		80000	7
B&G			58-62 HRC		40-44 HRC				
IME	8620	TiN	58-62 HRC	H-13 Malonite	40-44 HRC	Lithium		48000	8
B&G			54-56 HRC		40-42 HRC	PCS Nano		80000	9
PCS Clad	8620	Armorclad	58-62 HRC	O-6 Black Oxide	50-52 HRC				
China Brand	D-2	TiN	58-62 HRC	YC30 Oxide	50-52 HRC	Lithium		400	10

View the entire independent testing report online.

ALIGNMENT LOCKS

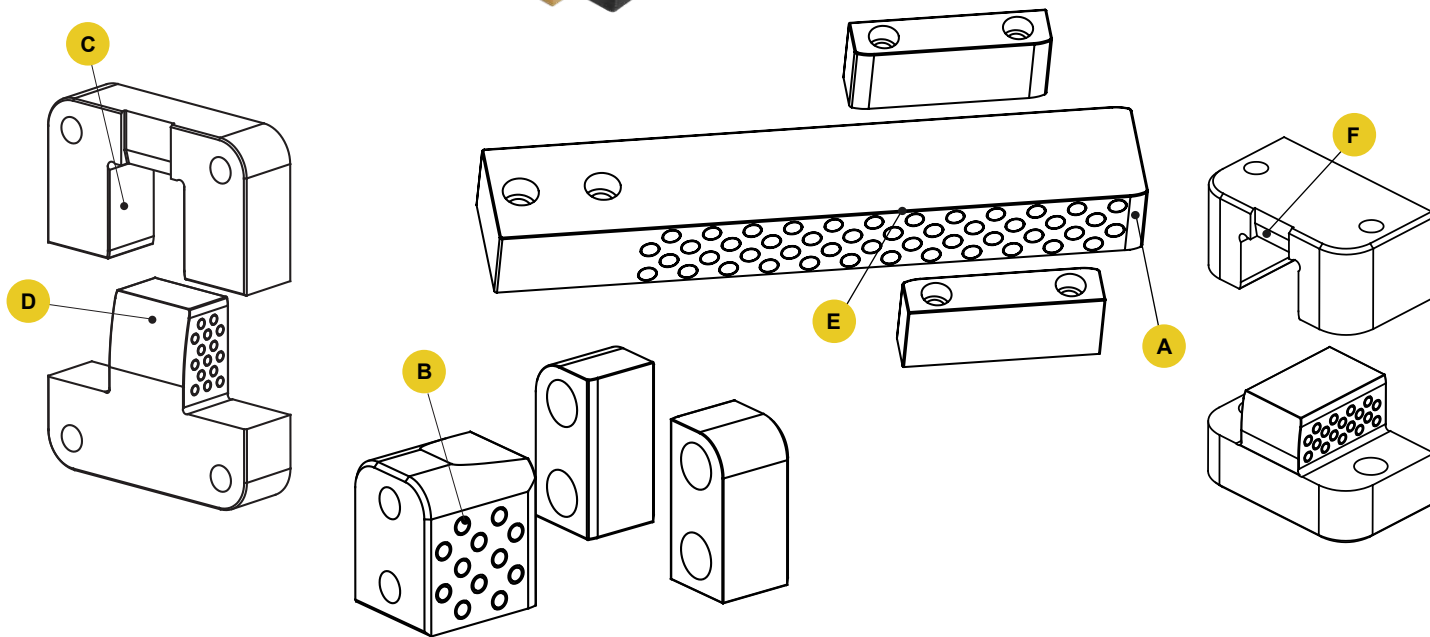
Z-SERIES®



Progressive's Alignment Locks have been advanced to outperform other styles. This is achieved through a combination of engagement geometry, particulate capturing rings, materials and treatments, and lubrication.

Benefits of the Z-Series Alignment Locks include:

- Longevity that far surpasses others, confirmed by extensive independent lab testing as well as monitoring performance in harsh, 'real world' conditions.
- Exclusive features maintain clean and consistent lubrication.
- Bar Lock, Guide Lock, Side Lock, X-Style Side Lock and Top Lock styles available with the features below, and Cavity Locks (Round and Flat), Tapered Bar Locks, and C'Bored Taper Locks are also available with the Z-Series treatments.



A Engagement Ramp: A fine finish radial lead-in for smooth lifting upon engagement of the mold halves.

B Particle Rings: Particle rings on the width of the male locks trap material and debris to avoid "picking up" or galling of the alignment surface.

C Longer Engagement: Using the maximum allowable engagement area on all locks surpasses previously-established industry standards.

D Arced Relief: Reduces the possibility of parts sticking to the lock at the bottom of the mold.

E Rounded Edges: A larger radius for all protruding surfaces to eliminate operator "reach in" injury.

F Pry Slot Lead-In: Expanded the entry of pry slots to ease removal.

Premium Materials: Males: H-13, 42-48 HRC, Surface: 70 HRC; Females: D-2, 58-62 HRC, Surface: 80 HRC.

Note: 500°F (260°C) max operating temperature.

Lubrication & Maintenance:

- Non-drying, non-hardening food grade grease is applied to all areas, including the particle rings.
- For production, install the locks and wipe down the outside of the locks only; maintain the grease on the mating surfaces and within the rings as provided.



SIDE/TOP/GUIDE LOCK SELECTION GUIDE

Refer to the chart below to match the correct alignment lock for the corresponding mold size and weight of the B-Side and press platen, using four locks per mold.

Clean and lubricate lock every 100,000 cycles, and prevent corrosion during mold storage.

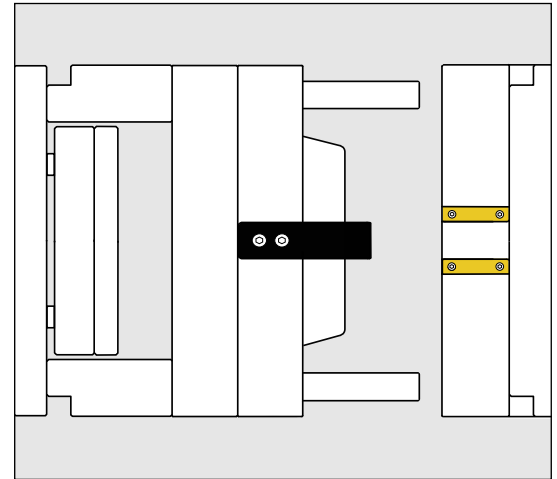
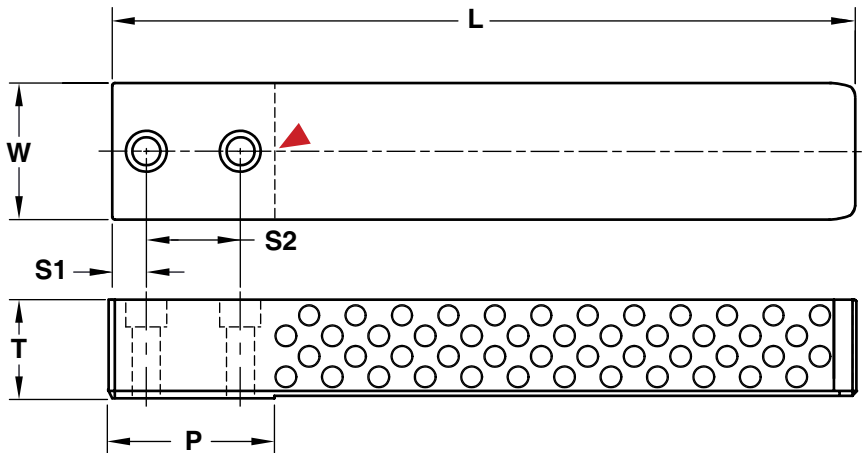
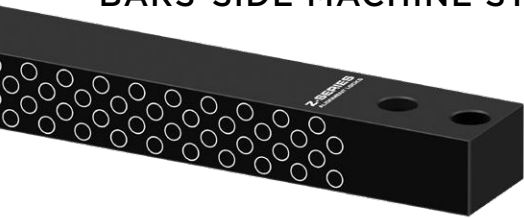
RECOMMENDED MAX MOLD SIZE (LXWXH)	SIDE LOCKS	METRIC SIDE LOCKS	GUIDE LOCKS	TOP LOCKS	TOTAL MAX WEIGHT B SIDE + PRESS PLATEN (LBS/KG)
RTI AND MOLDS 8 X 8 X 8 AND SMALLER	SL37X100, SL50X125 SL50X150, SL50X200 SLS62X150, SLS62X200 SLR50X125, SLR50X150	SLM16X50, SLPM16X20 SLPM16X40, SLPM20X25 SLPM20X50, SLSM13X38 SLSM16X50	GL100X150 GLM25X45	TL75X75, TLM20X20 TL50X100, TL62X125 TL75X125, TLM26X35 TLR87X150	2,000 / 900
11 X 16 X 10	SL50X125, SL50X150 SL50X200, SLS62X150 SLS62X200, SLS75X300 SLS75X400, SLR50X150 SLR50X200	SLM16X50, SLSM19X75 SLPM25X32, SLPM25X63 SLPM32X40, SLPM32X80 SLPM40X50, SLPM40X100 SLSM19X100	GL100X150 GL150X250 GLM25X45	TL62X125, TL75X125 TL100X100, TLM25X25 TLM26X35 TLR87X150, TLR112X200	5,000 / 2,300
16 X 24 X 16	SL50X150, SL50X200 SL75X300, SLS112X500 SLS75X300, SLS75X400 SLR75X300, SLR100X400	SLM19X75, SLSM19X100 SLSM25X125 SLPM50X56, SLPM50X112 SLRM32X63 SLRM40X100	GL150X250 GLM40X65	TL75X125, TL87X150 TL137X137, TLM32X32 TLM26X35, TLM30X45 TLR112X200 TLR150X250	7,000 / 3,200
28 X 34 X 24	SL75X300, SLS112X500	SLM19X75, SLSM19X100	GL200X350 GL150X250 GLM40X65	TL100X150, TL100X200 TL112X200, TL112X300 TLM26X35, TLM30X45	10,000 / 4,500
32 X 40 X 28	SL100X400	SLM25X125	GL200X350 GLM40X65	TL112X200, TL112X300 TLM36X55, TLM36X75	15,000 / 6,800
42 X 48 X 34	SL125X500		GL250X450 GLM50X90	TL150X250, TL175X300 TLM36X55, TLM36X75	20,000 / 9,000
48 X 52 X 38	SL150X600		GL250X450	TL175X300, TL200X350 TLM45X100	26,000 / 11,800

BAR LOCK SELECTION GUIDE

MALE BAR CATALOG NUMBER	GUIDE CATALOG NUMBER	BAR LOCK ENGAGEMENT	TOTAL MAX WEIGHT SUPPORTED (LBS/KG)
BLB100L4	BLG100L1.3, BLG100L1.8 BLG100L2.3, BLG100L2.8	2.50	10,000 / 4,500
BLBX137L5	BLGT137L1.3, BLGT137L1.8	3.00	
BLB100L6	BLG100L1.3, BLG100L1.8 BLG100L2.3, BLG100L2.8	4.50	
BLBT137L6	BLGT137L1.3, BLGT137L1.8		
BLBM25L125	BLGM25L27, BLGM25L36	89mm	15,000 / 6,800
BLB125L5	BLG125L1.3, BLG125L1.8 BLG125L2.3, BLG125L2.8	3.00	
BLBX162L6	BLGT162L1.3, BLGT162L2.3	3.50	
BLB125L9	BLG125L1.3, BLG125L1.8 BLG125L2.3, BLG125L2.8	7.00	
BLBT162L9	BLGT162L1.3, BLGT162L2.3		
BLBM32L160	BLGM32L36, BLGM32L46	114mm	
BLB137L6	BLG137L1.8, BLG137L2.3 BLG137L2.8, BLG137L3.3, BLG137L3.8	3.50	20,000 / 9,000
BLBX200L7	BLGT200L1.8 & BLGT200L2.8	4.50	
BLB137L11	BLG137L1.8, BLG137L2.3 BLG137L2.8, BLG137L3.3, BLG137L3.8	8.50	
BLBT200L11	BLGT200L1.8 & BLGT200L2.8		
BLBM38L250	BLGM38L46, BLGM38L76	194 mm	26,000 / 11,800
BLB150L8	BLG150L1.8, BLG150L2.3	4.50	
BLB150L16	BLG150L2.8, BLG150L3.3, BLG150L3.8	12.50	
BLN150L8	BLG150L1.8, BLG150L2.3 BLG150L2.8, BLG150L3.3, BLG150L3.8	3.75	
BLN250L10	BLG250L4.3	5.00	
BLN350L13	BLG350L4.8	6.00	75,000 / 34,000

BAR LOCKS

BAR-SIDE MACHINE STYLE



Inch Standard

M H-13 **H** Core: 42-48 HRC, Surface 70 HRC **S** Black Nitride

CAD insertion point

CATALOG NUMBER	L	T +.000 -.005	W +.0000 -.0005	P MINIMUM POCKET LENGTH	S1 ±.01	S2 ±.01	SHCS
BLB100L4	3.88	1.000	1.000	1.38	.38	.69	5/16-18 x 1-1/4
BLB100L6	6.00						
BLB125L5	4.88	1.250	1.500	1.88	.50	1.00	3/8 - 16 x 1-1/2
BLB125L9	8.88						
BLB137L6	5.88	1.375	2.000	2.38	.50	1.38	3/8 - 16 x 1-1/2
BLB137L11	10.88						
BLB150L8	7.88	1.500	3.000	3.38	.63	2.00	1/2 - 13 x 1-3/4
BLB150L16	15.88						

Bars are sold individually and include 2 screws.

Metric Standard

M H-13 **H** Core: 42-48 HRC, Surface 70 HRC **S** Black Nitride

CATALOG NUMBER	L	T +.0 -.1	W +.00 -.01	P MINIMUM POCKET LENGTH	S1 ±.25	S2 ±.25	SHCS
BLBM25L125	125	25	25	36	10	18	M8-1.25 x 30
BLBM32L160	160	32	38	46	12.5	25	M10-1.5 x 35
BLBM38L250	250	38	50	56	15	30	M12-1.75 x 45

Bars are sold individually and include 2 screws.

ALTERNATIVE CONFIGURATIONS AVAILABLE

- Guides are sold separately on page C-5.
- Bars can be cut to length and/or have radii machined. Refer to page C-7 for details.
- Made-to-order Bar Locks can be quoted using the templates at procomps.com.



BAR LOCKS

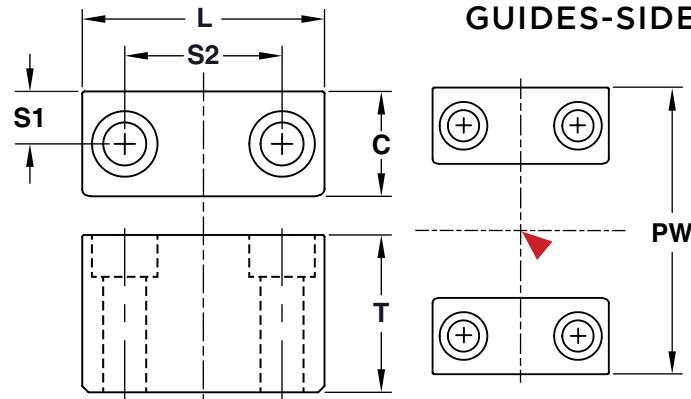
GUIDES-SIDE MACHINE STYLE

PW Tolerances:

Standard Bars:
+.0003/+.0006
(+.007/+.015mm)

Inserted Bars:
+.0010/+.0015
(+.025/+.038mm)

▶ CAD insertion point



M D-2 **H** Core: 58-62 HRC, Surface 80 HRC **S** Titanium Nitride Coated

Inch Standard

CATALOG NUMBER	T +.000 -.005	L +.000 -.005	C +.0000 -.0003	S1 ±.01	S2 ±.01	PW	SHCS	USE WITH
BLG100L1.3	1.000	1.310	.500	.25	.75	2.000	#10-32 x 1-1/4	BLB100L4 & BLB100L6
BLG100L1.8		1.810			1.12			
BLG100L2.3		2.310			1.25			
BLG100L2.8		2.810			1.625			
BLG125L1.3	1.250	1.310	.625	.31	.75	2.750	1/4-20 x 1-1/2	BLB125L5 & BLB125L9
BLG125L1.8		1.810			1.12			
BLG125L2.3		2.310			1.25			
BLG125L2.8		2.810			1.62			
BLG137L1.8	1.375	1.810	.750	.37	1.12	3.500	5/16-18 x 1-1/2	BLB137L6 & BLB137L11
BLG137L2.3		2.310			1.25			
BLG137L2.8		2.810			1.62			
BLG137L3.3		3.310			2.25			
BLG137L3.8		3.810			2.50			
BLG150L1.8	1.500	1.810	1.000	.50	1.00	5.000 (6.000 for BLN150)	3/8-16 x 1-3/4	BLN150L8, BLB150L8, & BLB150L16
BLG150L2.3		2.310			1.50			
BLG150L2.8		2.810			1.62			
BLG150L3.3		3.310			2.25			
BLG150L3.8		3.810			2.50			
BLG250L4.3	2.500	4.310	1.250	.62	3.00	7.500	1/2-13 x 2-3/4	BLN250L10
BLG350L4.8	3.500	4.810	1.750	.87	3.25	9.500	5/8-11 x 3-3/4	BLN350L13

M D-2 **H** Core: 58-62 HRC, Surface 80 HRC **S** Titanium Nitride Coated

Metric Standard

CATALOG NUMBER	T +0 -1	L +0 -1	C +.000 -.007	S1 ±.25	S2 ±.25	PW	SHCS	USE WITH
BLGM25L27	25	27	12	6	14	49	M4-0.7 x 25	BLBM25L125
BLGM25L36		36			20			
BLGM32L36	32	36	16	8	20	70	M6-1.0 x 35	BLBM32L160
BLGM32L46		46			30			
BLGM38L46	38	46	22	11	24	94	M10-1.5 x 40	BLBM38L250
BLGM38L76		76			54			

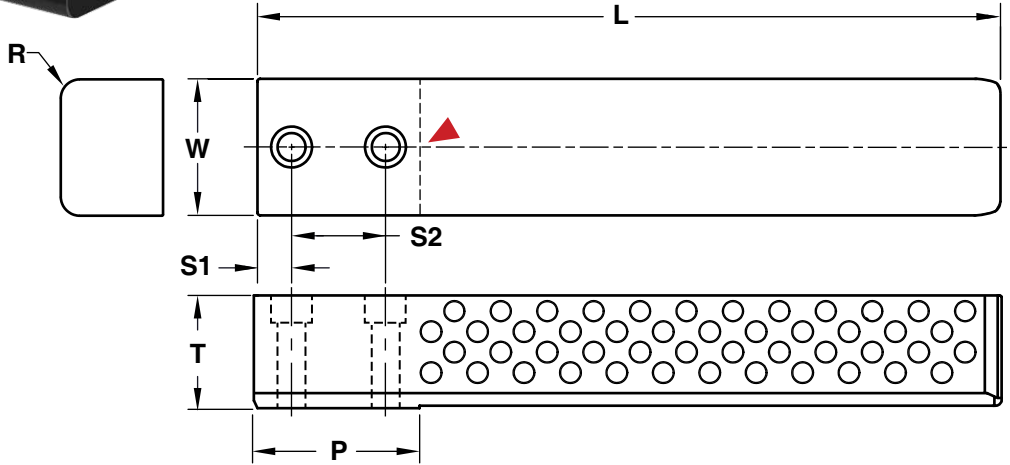
ALTERNATIVE CONFIGURATIONS AVAILABLE

- Side Machine Bars are sold separately on page C-4. Inserted Bar Locks are sold on page C-9.
- Guides can have 2 or 4 radii machined. Refer to page C-7 for details.
- Made-to-order Guides can be quoted using the templates at procomps.com.

APPLICATION GUIDELINES

- Guides are sold in pairs. Each set includes 2 Guides and 4 Screws.
- Refer to page C-8 for application guidelines.

BAR LOCKS
BARS-TOP MACHINE STYLE

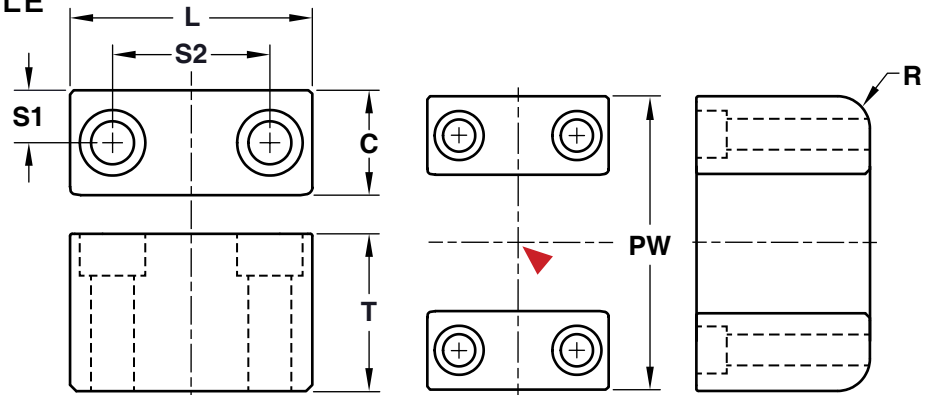


M H-13 **H** Core: 42-48 HRC, Surface 70 HRC **S** Black Nitride ▶ CAD insertion point

CATALOG NUMBER	L	T +.000 -.005	W +.0000 -.0005	P MINIMUM POCKET LENGTH	R POCKET RADIUS	S1 ±.01	S2 ±.01	SHCS
BLBT137L6	6.00	1.375	1.625	1.375	.250	.38	.69	5/16-18 x 1-1/2
BLBT162L9	8.88	1.625	2.250	1.875	.312	.50	1.00	3/8-16 x 1-3/4
BLBT200L11	10.88	2.000	3.000	2.375	.375	.63	1.25	1/2-13 x 2-1/4

Bars are sold individually and include 2 screws.

GUIDES-TOP MACHINE STYLE



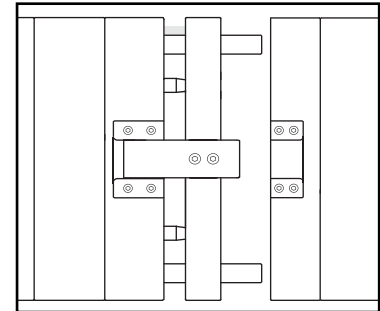
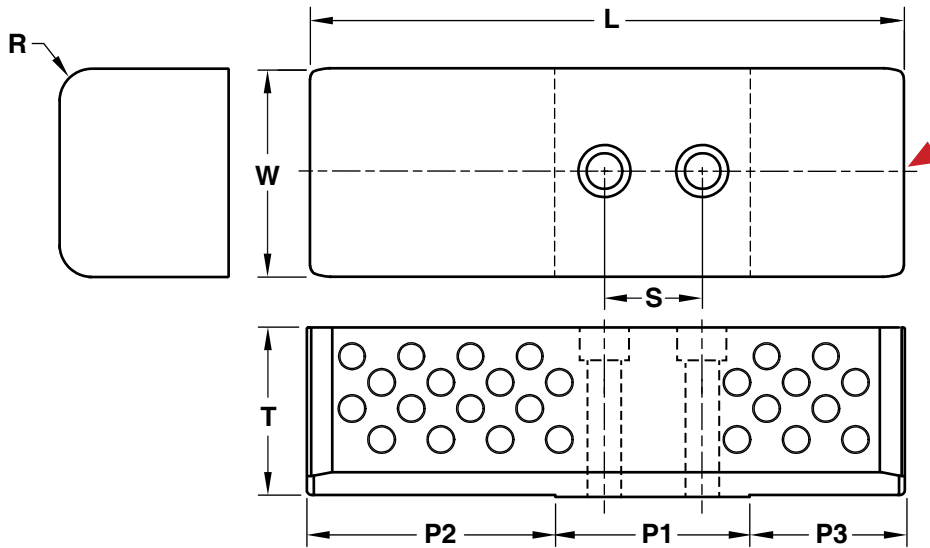
M D-2 **H** Core: 58-62 HRC, Surface 80 HRC **S** Titanium Nitride Coated ▶ CAD insertion point

CATALOG NUMBER	T +.000 -.005	L +.000 -.005	C +.0000 -.0003	R POCKET RADIUS	S1 ±.01	S2 ±.01	PW +.0003 +.0006	SHCS	USE WITH
BLGT137L1.3	1.375	1.310	1.000	.250	.50	.75	3.625	#10-32 x 1-1/2	BLBT137L6
BLGT137L1.8		1.810				1.12			
BLGT162L1.3	1.625	1.310	1.125	.312	.56	.75	4.500	1/4-20 x 1-3/4	BLBT162L9
BLGT162L2.3		2.310				1.25			
BLGT200L1.8	2.000	1.810	1.375	.375	.69	1.12	5.750	5/16-18 x 2-1/4	BLBT200L11
BLGT200L2.8		2.810				1.62			

Guides are sold in pairs. Each set includes 2 Guides and 4 Screws.



BAR LOCKS X-STYLE



M H-13 **H** Core: 42-48 HRC, Surface 70 HRC **S** Black Nitride

▶ CAD insertion point

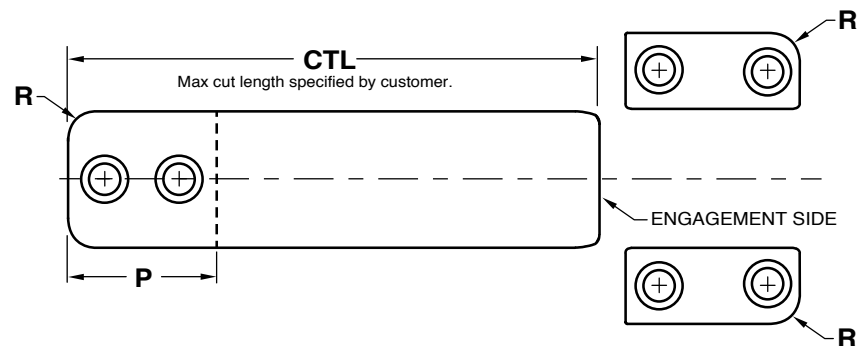
CATALOG NUMBER	L	T +.000 -.005	W +.0000 -.0005	P1 MINIMUM POCKET LENGTH	P2 MIN. PLATE THICKNESS	P3 MIN. PLATE THICKNESS	R POCKET RADIUS	S ±.01	SHCS
BLBX137L5	4.63	1.375	1.625	1.375	1.88	1.38	.250	.69	5/16-18 x 1-1/2
BLBX162L6	5.63	1.625	2.250	1.875	2.38	1.38	.312	1.00	3/8-16 x 1-3/4
BLBX200L7	7.13	2.000	3.000	2.375	2.88	1.88	.375	1.25	1/2-13 x 2-1/4

Bars are sold individually and include 2 screws. Top machine style Guides are sold on page C-6.

MOLD-READY SPECIALS

To Order:

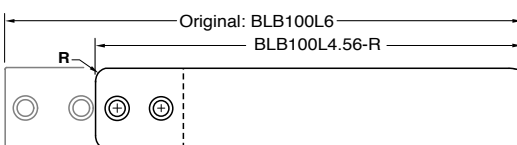
- For cut-to-length Side Machine Bars (pg C-4) or Top Machine Bars (pg C-6), specify the prefix of the Bar and the finished length. Ex. BLB100L4.56. (See max CTL length in the chart below.)
- For Side Machine Bars cut to length with pocket radii with sizes shown in the chart, specify the size, length and add "-R" suffix. Ex. BLB100L4.56-R.
- For Side Machine Bars with pocket radii in standard lengths, add "-R" to the end of the catalog number. Ex. BLB100L6-R.
- For Side Machine Guides with corner radii on both parts, add "-R" to the end of the catalog number. Ex. BLG150L2.8-R.



Note: Mold-Ready Specials must have a minimum quantity of (2) Bars or (2) sets of Guides per order.

APPLICATION GUIDELINES

- For Guides, the pocket radii are machined on opposing sides as shown above.
- Bar lengths are modified from standards and radii (for Side Machine Bars) are machined on the pocket side to maintain the integrity of the material and treatment on the engagement side.

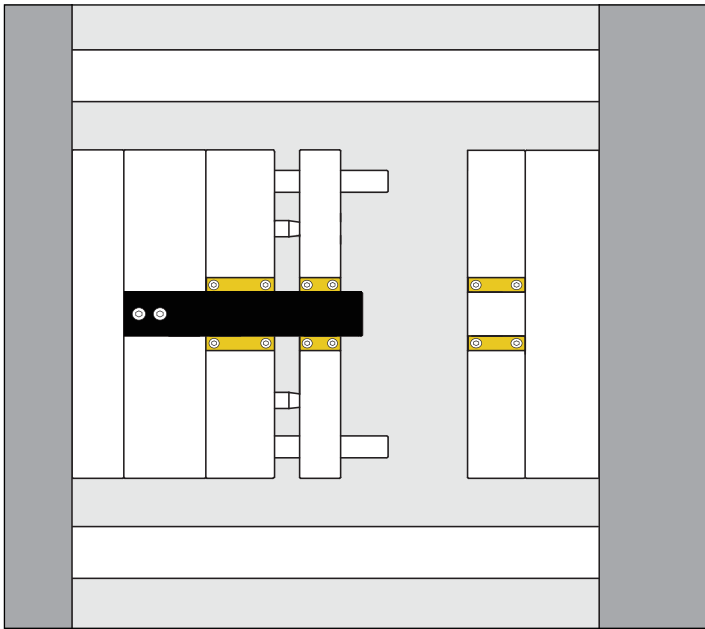


BAR CATALOG PREFIX	CTL MAX	R POCKET RADIUS
BLB100	4.62	.25
BLB125	7.00	.31
BLB137	8.50	.37
BLBT137	4.62	N/A
BLB150	12.50	.50
BLBT162	7.00	N/A
BLBT200	8.50	N/A
BLBM25	89mm	6 mm
BLBM32	114mm	8 mm
BLBM38	194mm	10 mm

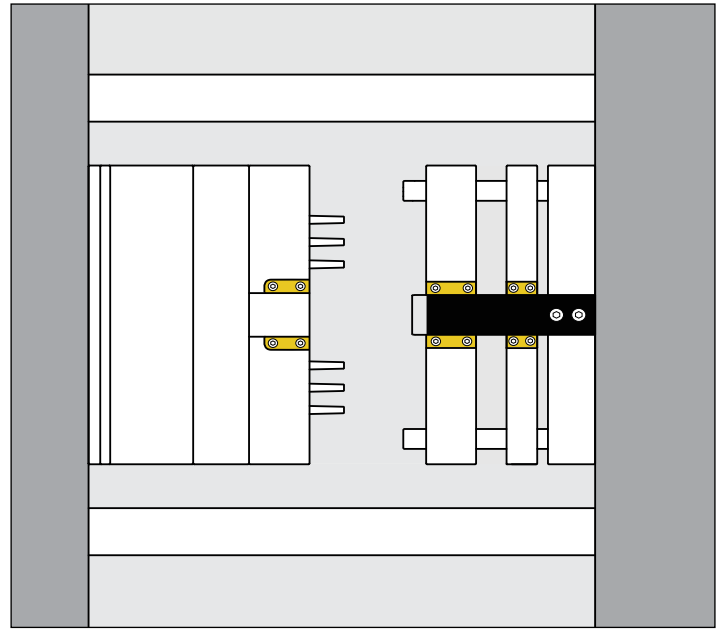
GUIDE CATALOG PREFIX	R POCKET RADIUS
BLG100	.18
BLG125	.25
BLG137	.31
BLG150	.37
BLG250	.37
BLG350	.50
BLGM25	5mm
BLGM32	6mm
BLGM38	7mm

BAR LOCKS APPLICATIONS

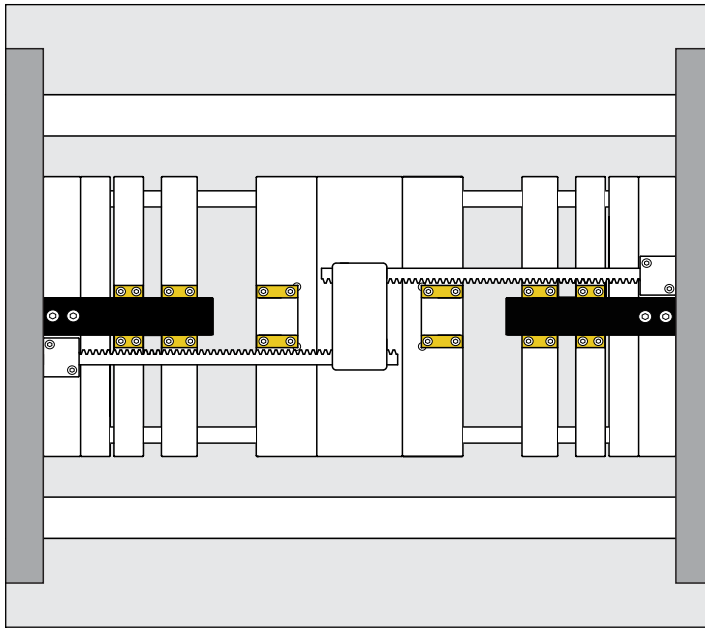
Stripper Plate Application



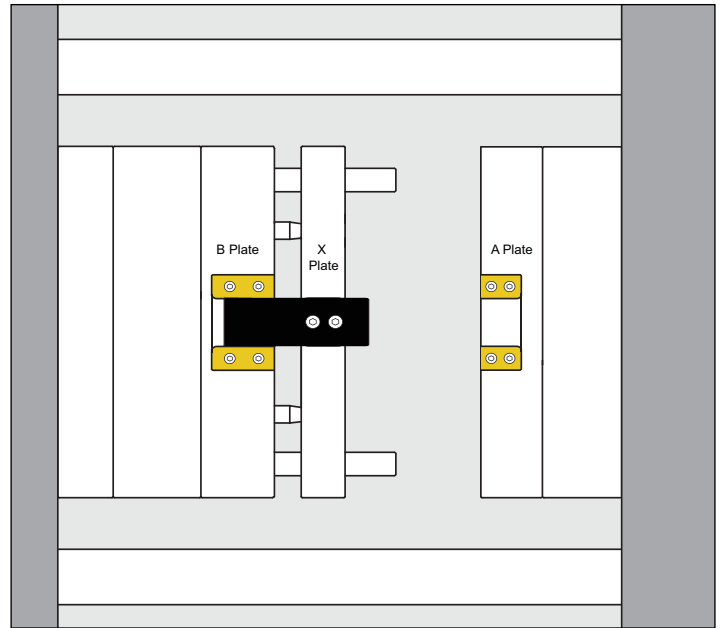
Three Plate Application



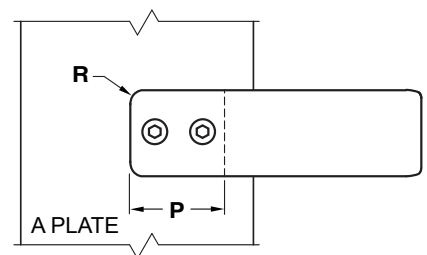
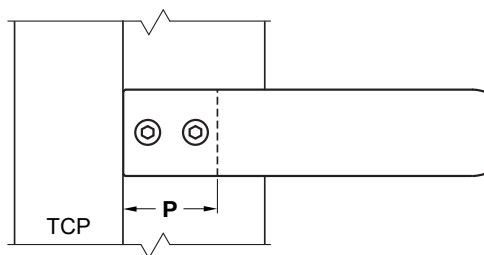
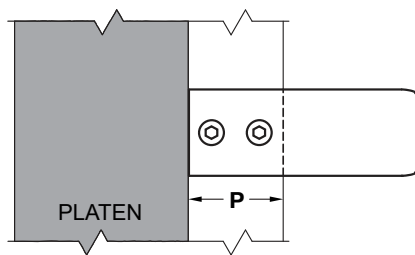
Stack Mold Application



Floating Plate Application

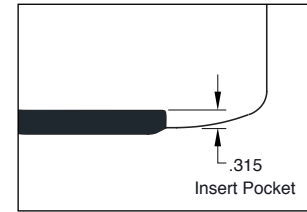
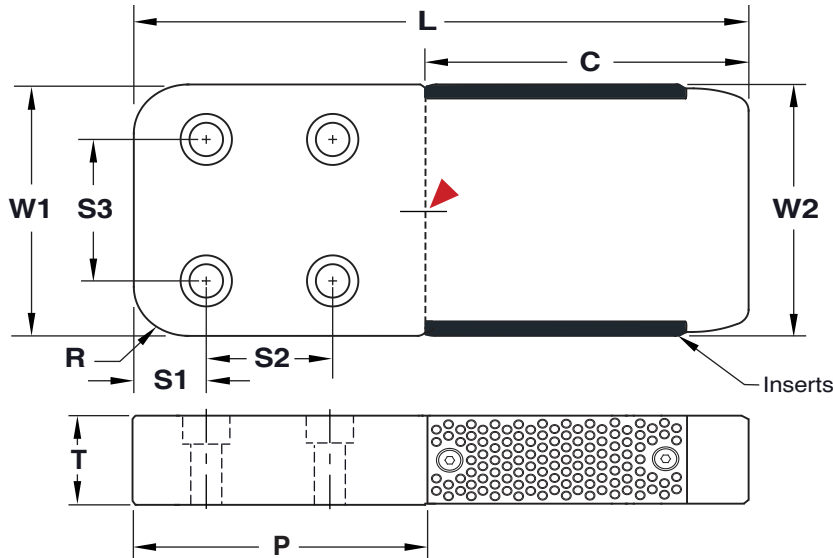
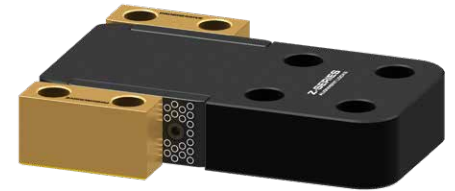


The minimum pocket length (P) is shown below in different applications.





BAR LOCKS INSERTED



MALE BAR LOCK ASSEMBLIES

Bar: **M** 4140 **H** Core: 36-40 HRC, Surface 70 HRC **S** Black Oxide
 Inserts: **M** H-13 **H** Core: 42-48 HRC, Surface 70 HRC **S** Black Nitride

CAD insertion point

CATALOG NUMBER	T +.000 -.005	W1 +.0000 -.0005	W2	L	C REF	S1 ±.01	S2 ±.01	S3 ±.01	R POCKET RADIUS	P MINIMUM POCKET LENGTH	SHCS
BLN150L8	1.500	4.000	4.000 +.000 -.002	7.75	3.75	1.00	2.00	2.25	.75	4.00	1/2-13 x 1-3/4
BLN250L10	2.500	5.000	5.000 +.000 -.002	10.38	5.00	1.25	3.25	3.25	1.00	5.38	5/8-11 x 2-3/4
BLN350L13	3.500	6.000	6.000 +.000 -.003	12.88	6.00	1.50	4.00	3.50	1.00	6.88	3/4-10 x 3-3/4

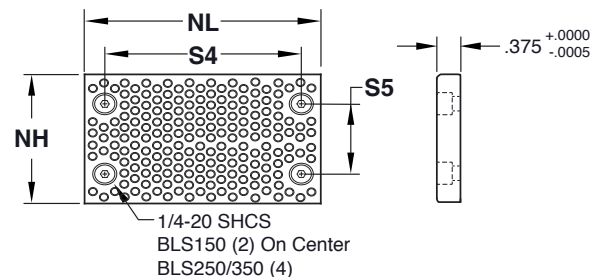
Each catalog number includes (1) Bar and (2) Inserts with screws. Guides are sold separately on page C-5.

INSERTS

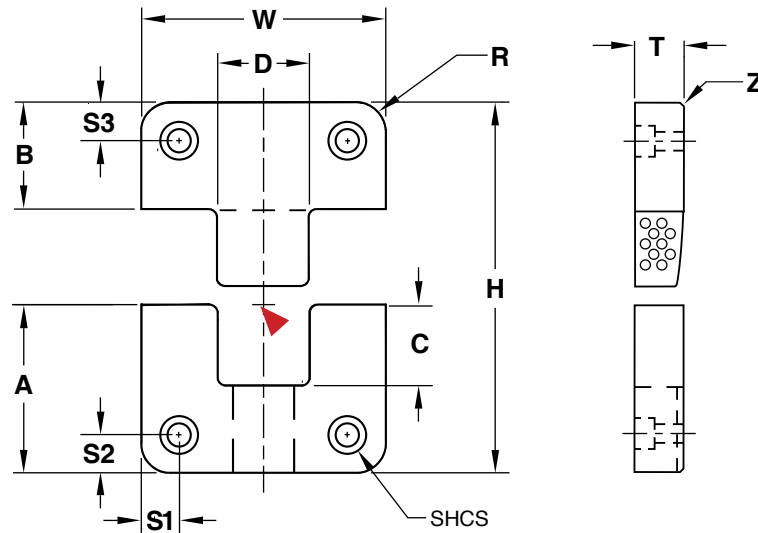
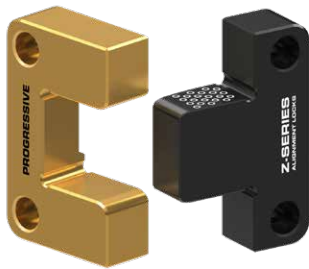
M H-13 **H** Core: 42-48 HRC, Surface 70 HRC **S** Black Nitride

CATALOG NUMBER	NH +.000 -.005	NL +.000 -.002	S4 ±.01	S5 ±.01
BLS150	1.440	2.999	1.75	---
BLS250	2.440	3.999	2.25	1.50
BLS350	3.375	4.999	3.00	2.50

Inserts sold individually and include screws.



SIDE LOCKS
Z-SERIES



Inch Standard

Female: **M** D-2 **H** Core: 58-62 HRC, Surface: 80 HRC **S** Titanium Nitride Coated
 Male: **M** H-13 **H** Core: 42-48 HRC, Surface: 70 HRC **S** Black Nitride

CAD insertion point

CATALOG NUMBER	T +.000 -.002	W +.0000 -.0004	A +.000 -.002	B +.000 -.002	C	D .0001/.0003 CLEARANCE PER SIDE	H +.000 -.004	R POCKET RADIUS	S1 ±.01	S2 ±.01	S3 ±.01	Z	SHCS
SL37X100	.375	1.000	1.125	.875	.62	.500	2.000	.187	.25	.25	.25	.015	#10-32 x 1/2
SL50X125	.490	1.250	1.125	.875	.68	.500	2.000	.187	.25	.25	.25	.03	#8-32 x 5/8
SL50X150	.500	1.500	.875	.875	.56	.563	1.750	.187	.25	.25	.25	.03	#8-32 x 5/8
SL50X200	.500	2.000	1.375	.875	.86	.750	2.250	.187	.31	.31	.31	.03	#10-32 x 5/8
SL62X150	.620	1.500	.870	.870	.41	.500	1.74	.187	.28	.28	.43	.03	1/4-20 x 3/4
SL62X200	.620	2.000	.870	.870	.41	.680	1.74	.187	.37	.37	.43	.03	1/4-20 x 3/4
SL75X300	.750	3.000	1.875	.875	1.18	1.250	2.750	.250	.37	.37	.37	.03	1/4-20 x 3/4
SLC75X300	.745	3.000	1.370	1.360	.68	1.000	2.73	.187	.37	.68	.68	.03	3/8-16 x 1
SL100X400	1.000	4.000	2.375	1.375	1.43	1.500	3.750	.500	.50	.50	.50	.03	3/8-16 x 1
SL125X500	1.250	5.000	2.875	1.375	1.75	2.000	4.250	.500	.62	.62	.62	.03	1/2-13 x 1-1/4
SL150X600	1.500	6.000	2.875	1.375	1.87	2.500	4.250	.500	.62	.62	.62	.03	1/2-13 x 1-1/2

Screws included.

Metric Standard

CATALOG NUMBER	T +.00 -.05	W +.00 -.01	A +.00 -.05	B +.00 -.05	C	D .002/.008 CLEARANCE PER SIDE	H + 0.0 - 0.1	R POCKET RADIUS	S1 ±.25	S2/S3 ±.25	Z	SHCS
SLM16X50	16	50	21.5	21.5	13	17	43	5	8	11	.8	M6-1.0 x 18
SLM19X75	19	75	36	36	22.5	25	72	5	12.5	18	.8	M10-1.5 x 20
SLM19X100	19	100	45	45	30	35	90	5	15	22	.8	M10-1.5 x 20
SLM25X125	25	125	45	45	28.7	35	90	5	20.5	22	.8	M10-1.5 x 25

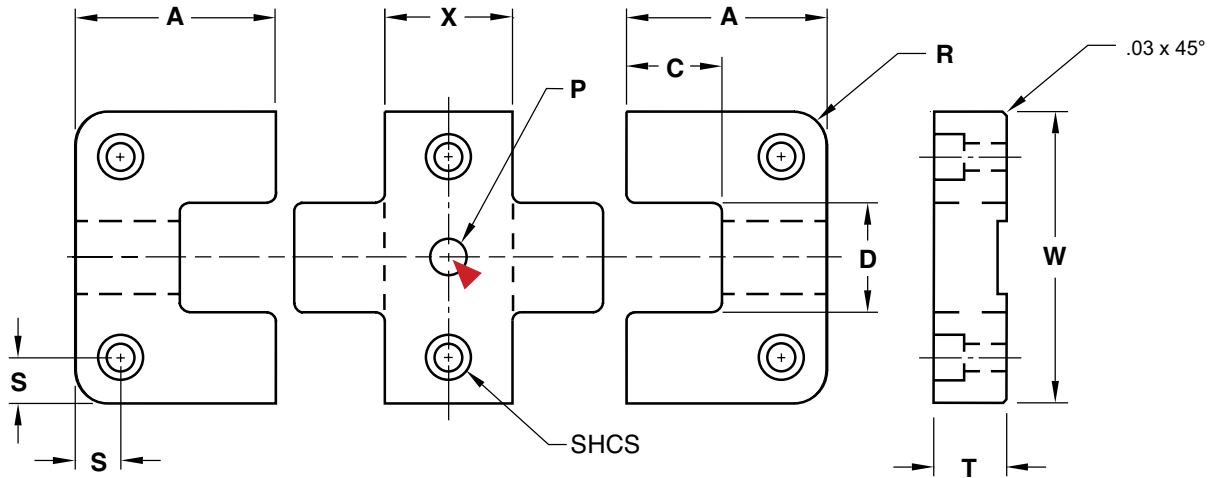
Screws included.

ALTERNATIVE CONFIGURATIONS AVAILABLE

- To order Shuttle Mold sets or special male/female configurations, refer to page C-11.
- Made-to-order Side Locks can be quoted using the templates at procomps.com.



X-STYLE SIDE LOCKS Z-SERIES



Females (2): **M** D-2 **H** Core: 58-62 HRC, Surface: 80 HRC **S** Titanium Nitride Coated

Male: **M** H-13 **H** Core: 42-48 HRC, Surface: 70 HRC **S** Black Nitride

CAD insertion point

CATALOG NUMBER	T +.000 -.002	W +.0000 -.0004	X +.000 -.002	A +.000 -.002	C ±.01	D .0001/.0003 CLEARANCE PER SIDE	R POCKET RADIUS	S ±.01	P +.001 -.000	SHCS
SLX50X87	.500	2.000	.875	1.375	.87	.750	.187	.31	.250	#10-32 x 5/8
SLX75X137	.750	3.000	1.375	1.875	1.18	1.250	.250	.37	.313	1/4-20 x 3/4
SLX75X187	.750	3.000	1.875	1.875	1.18	1.250	.250	.37	.313	1/4-20 x 3/4
SLX100X137	1.000	4.000	1.375	2.375	1.43	1.500	.500	.50	.375	3/8-16 x 1

Screws included.

ALTERNATIVE CONFIGURATIONS AVAILABLE

- Made-to-order Side Locks can be quoted using the templates at procomps.com.

Examples of Shuttle Mold configurations:

2 Female Inserts : 1 Male Insert

To order, specify "-SF" after the catalog number of the lock.

Examples: SL50X200-SF GL100X150-SF TL75X125-SF
TL50X100-R-SF CF31X62-SF CRSM08-SF

2 Male Inserts : 1 Female Insert

To order, specify "-SM" after the catalog number of the lock.

Example: SL75X300-SM GL250X450-SM TL112X200-SM
TL150X250-R-SM CF31X62-SM CRSM08-SM

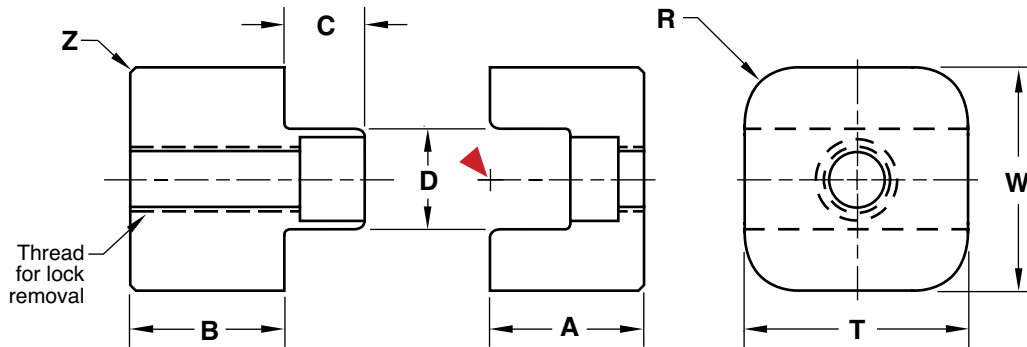
Individual males and females and special configurations (Ex. 4M:1F) are available. Contact Customer Service for pricing and availability.

SHUTTLE MOLD SETS



INTERNAL TOP LOCKS

Z-SERIES



Inch Standard

Female: **M** D-2 **H** Core: 58-62 HRC, Surface: 80 HRC **S** Titanium Nitride Coated

Male: **M** H-13 **H** Core: 42-48 HRC, Surface: 70 HRC **S** Black Nitride

CAD insertion point

CATALOG NUMBER	T +.000 -.002	W +.0000 -.0004	A +.000 -.002	B +.000 -.002	C	D .0001/.0003 CLEARANCE PER SIDE	R POCKET RADIUS	Z	SHCS	
TL75X75	.750	.750	.625	.375	.275	.350	.188	.04	M: #6-32 x 3/4	F: #6-32 x 3/8
TL100X100	1.000	1.000	.875	.500	.450	.500	.250	.04	M: #10-32 x 1	F: #10-32 x 1/2
TL137X137	1.375	1.375	1.125	.625	.550	.750	.375	.04	M: 5/16-18 x 1-3/8	F: 5/16-18 x 3/4

Screws included.

Metric Standard

CATALOG NUMBER	T +.00 -.05	W +.00 -.01	A +.00 -.05	B +.00 -.05	C	D .002/.008 CLEARANCE PER SIDE	R POCKET RADIUS	Z	SHCS	
TLM20X20	20	20	14	14	7	9	5	1	M: M4 x 25	F: M4 x 10
TLM25X25	25	25	16	16	8	12	6	1	M: M5 x 25	F: M5 x 10
TLM32X32	32	32	20	20	10	16	7	1	M: M6 x 35	F: M6 x 12

Screws included.

APPLICATION GUIDELINES

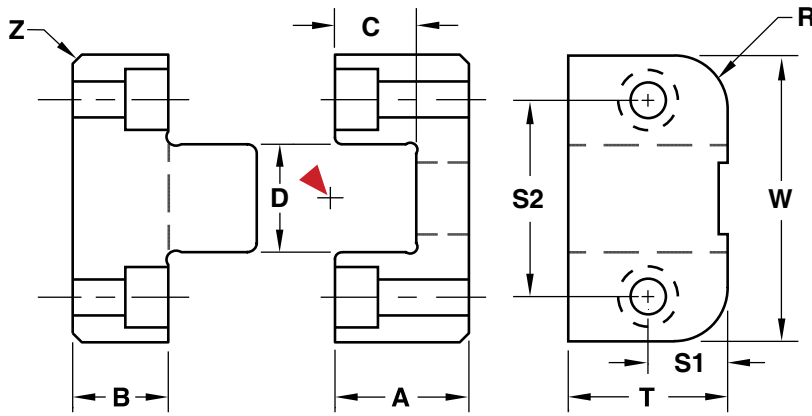
- Internal Top Locks are designed to be installed into inserts or small/medium mold bases.

ALTERNATIVE CONFIGURATIONS AVAILABLE

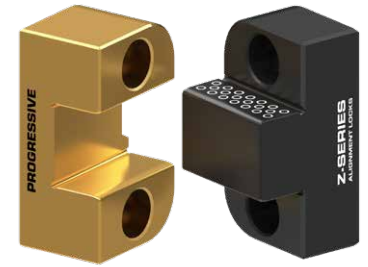
- To order Shuttle Mold sets or special male/female configurations, refer to page C-11.
- Made-to-order Top Locks can be quoted using the templates at procomps.com.



TOP LOCKS
Z-SERIES



▶ CAD insertion point



Female: **M** D-2 **H** Core: 58-62 HRC, Surface: 80 HRC **S** Titanium Nitride Coated
 Male: **M** H-13 **H** Core: 42-48 HRC, Surface: 70 HRC **S** Black Nitride

Inch Standard

CATALOG NUMBER	T +.000 -.002	W +.0000 -.0004	A +.000 -.002	B +.000 -.002	C	D .0001/.0003 CLEARANCE PER SIDE	S1 ±.01	S2 ±.01	R POCKET RADIUS	Z	SHCS	
TL50X100	.500	1.000	.500	.375	.30	.375	.25	.68	.188	.03	M: #6-32 x 1/2	F: #6-32 x 5/8
TL62X125	.625	1.250	.625	.500	.41	.438	.31	.87	.250	.03	M: #6-32 x 5/8	F: #6-32 x 3/4
TL75X125	.750	1.250	.625	.500	.38	.438	.37	.87	.250	.04	M: #8-32 x 5/8	F: #8-32 x 3/4
TL87X150	.875	1.500	.875	.750	.57	.500	.43	1.00	.250	.04	M: #8-32 x 7/8	F: #8-32 x 1
TL100X150	1.000	1.500	.875	.375	.57	.500	.50	1.00	.250	.04	M: #10-32 x 1/2	F: #10-32 x 1
TL100X200	1.000	2.000	1.125	.750	.75	.750	.50	1.37	.375	.04	M: #10-32 x 7/8	F: #10-32 x 1-1/8
TL112X200	1.125	2.000	.875	.625	.50	.750	.56	1.37	.375	.04	M: 1/4-20 x 3/4	F: 1/4-20 x 1
TL112X300	1.125	3.000	1.500	.750	.87	1.125	.56	2.25	.500	.04	M: 1/4-20 x 7/8	F: 1/4-20 x 1-5/8
TL150X250	1.500	2.500	1.375	.625	.85	1.000	.75	1.75	.375	.04	M: 1/4-20 x 3/4	F: 1/4-20 x 1-1/2
TL175X300	1.750	3.000	1.250	.875	.75	1.125	.87	2.25	.500	.06	M: 5/16-18 x 1	F: 5/16-18 x 1-1/4
TL200X350	2.000	3.500	1.750	.750	1.07	1.500	1.00	2.50	.500	.06	M: 3/8-16 x 7/8	F: 3/8-16 x 2"

Screws included.

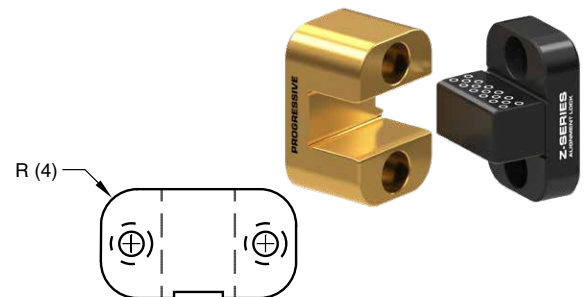
Metric Standard

CATALOG NUMBER	T +.00 -.05	W +.00 -.01	A +.00 -.05	B +.00 -.05	C	D .002/.008 CLEARANCE PER SIDE	S1 ±.25	S2 ±.25	R POCKET RADIUS	Z	SHCS	
TLM26X35	26	35	25	15	17	11	13	23	8	1	M: M5 x 16	F: M5 x 25
TLM30X45	30	45	25	15	17	15	15	30	8	1	M: M6 x 18	F: M6 x 25
TLM36X55	36	55	30	20	21.5	20	18	37.5	8	1	M: M8 x 22	F: M8 x 35
TLM36X75	36	75	35	20	26	30	18	52	8	1.5	M: M10 x 25	F: M10 x 35
TLM45X100	45	100	60	20	42	40	22.5	70	8	1.5	M: M10 x 25	F: M10 x 65

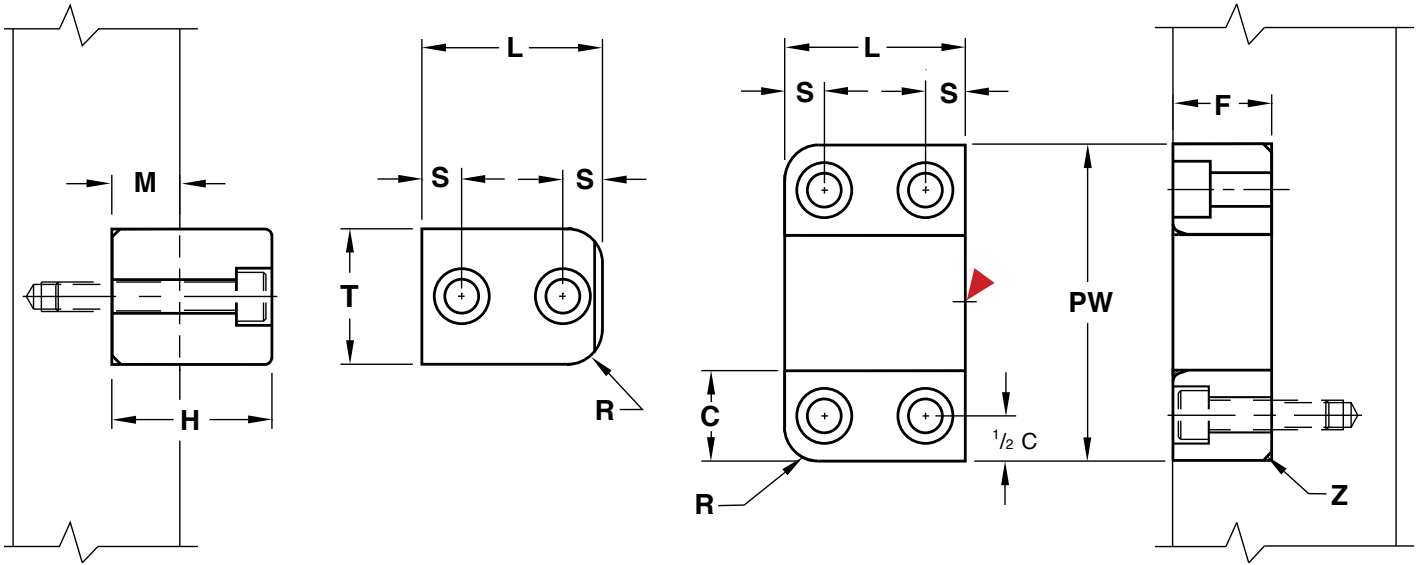
Screws included.

ALTERNATIVE CONFIGURATIONS AVAILABLE

- To order Top Locks with dual radii for mounting internally, specify the catalog number followed by "-R". Ex. TL112X300-R. As an option, refer to the standard Internal Locks shown on page C-12.
- To order Shuttle Mold sets or special male/female configurations, refer to page C-11.
- Made-to-order Top Locks can be quoted using the templates at procomps.com.



GUIDE LOCKS
Z-SERIES



Inch Standard

Females (2): **M** D-2 **H** Core: 58-62 HRC, Surface: 80 HRC **S** Titanium Nitride Coated

Male: **M** H-13 **H** Core: 42-48 HRC, Surface: 70 HRC **S** Black Nitride

CAD insertion point

CATALOG NUMBER	L +.000 -.010	PW +.0003 +.0006	C +.0000 -.0003	F +.000 -.005	T +.0000 -.0003	M	H +.00 -.01	S ±.01	R POCKET RADIUS	Z	SHCS	
GL100X150	1.000	1.500	.500	.500	.500	.375	.85	.25	.187	.03	M: #10-32 x 1	F: #10-32 x 5/8
GL150X250	1.500	2.500	.750	.750	1.000	.625	1.35	.31	.250	.06	M: 1/4-20 x 1-1/2	F: 1/4-20 x 7/8
GL200X350	2.000	3.500	1.000	1.000	1.500	.750	1.73	.44	.375	.06	M: 3/8-16 x 2	F: 3/8-16 x 1-1/4
GL250X450	2.500	4.500	1.250	1.250	2.000	.875	2.11	.56	.500	.09	M: 1/2-13 x 2-1/4	F: 1/2-13 x 1-1/2

Screws included.

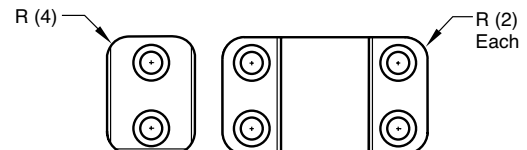
Metric Standard

CATALOG NUMBER	L +.00 -.25	PW +.008 +.015	C +.00 -.01	F +.00 -.12	T +.00 -.01	M	H +.0 -.2	S ±.25	R POCKET RADIUS	Z	SHCS	
GLM25X45	25	45	15	15	15	10	24	7	4	1	M: M4 x 25	F: M4 x 14
GLM40X65	40	65	20	20	25	15	34	10	9	1.5	M: M5 x 35	F: M5 x 22
GLM50X90	50	90	25	25	40	20	44	10	9	1.5	M: M6 x 45	F: M6 x 30

Screws included.

ALTERNATIVE CONFIGURATIONS AVAILABLE

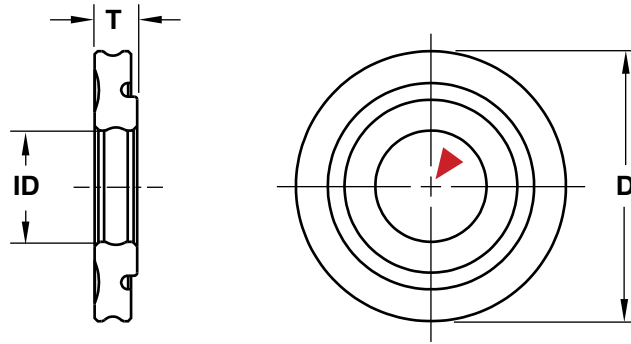
- To order Guide Locks with dual radii for mounting internally, specify the catalog number followed by "-R". Ex. GL200X350-R.
- Made-to-order Guide Locks can be quoted using the templates at procomps.com.





RADIAL SPRINGS

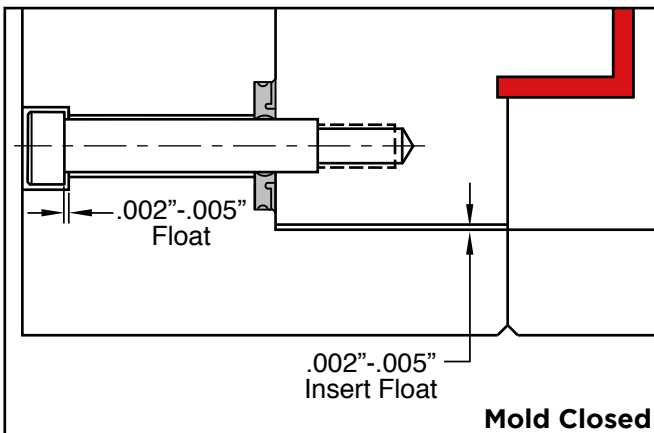
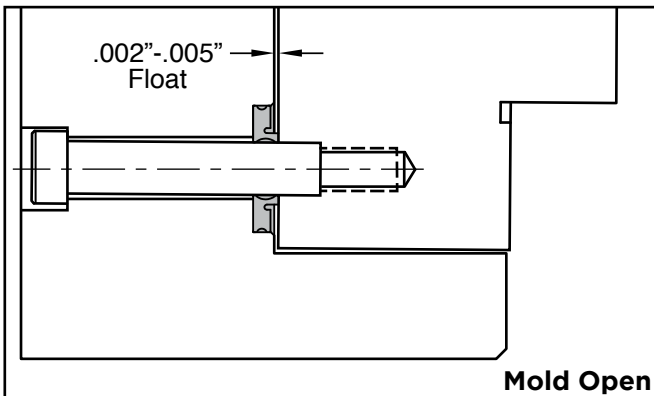
FLOATING INSERT CENTERING SPRING



M TPA **H** 91A

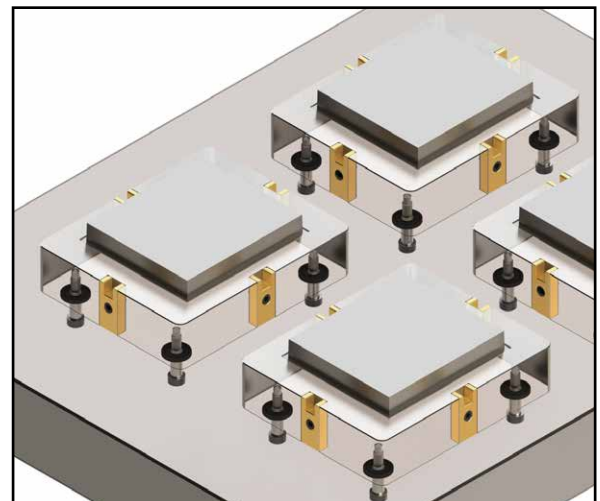
▶ CAD insertion point

CATALOG NUMBER	ID STRIPPER BOLT DIAMETER	D POCKET DIAMETER ±.001	T POCKET DEPTH ±.001	MAX INSERT WEIGHT (LBS)
RS250	1/4	.500	.125	50
RS312	5/16	.750	.125	75
RS375	3/8	.875	.125	100
RS500	1/2	1.000	.125	150

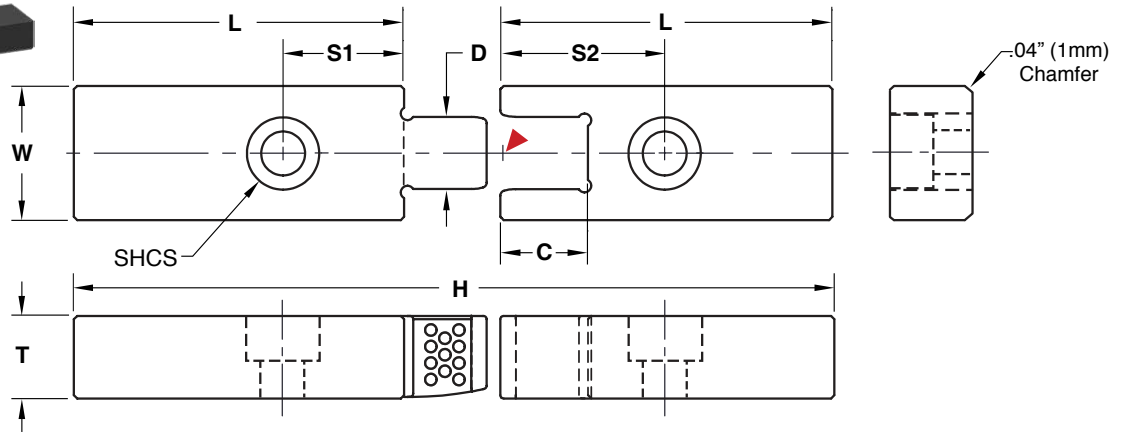


APPLICATION GUIDELINES

- Radial Springs both lift and center floating inserts before locks engage to protect telescoping shut offs.
- Install on core half as shown below.
- For best performance, use four Stripper Bolts and Radial Springs per insert with four Cavity Locks. Stripper Bolts are sold on page B-28 and Cavity Locks are on pages C-16 (Flat) and C-17 (Round).
- Max Temperature: 200°F (93°C)



CAVITY INTERLOCKS FLAT SERIES



Inch Standard

Male: **M** H-13 **H** Core: 42-48 HRC, Surface: 70 HRC **S** Black Nitride

Female: **M** DC53 **H** Core: 58-62 HRC, Surface: 80 HRC **S** Titanium Nitride Coated

CAD insertion point

CATALOG NUMBER	T +.000 -.002	W +.0000 -.0002	L +.000 -.002	C	D .0001/.00025 CLEARANCE PER SIDE	H +.000 -.004	S1 ±.01	S2 ±.01	SHCS
CF31X62	.312	.625	1.875	.343	.312	3.750	.68	.68	#8-32 x 3/8"
CF50X87	.500	.875	2.875	.530	.438	5.750	1.00	1.00	1/4-20 x 5/8"

Screws included.

Metric Standard

Male: **M** H-13 **H** Core: 42-48 HRC, Surface: 70 HRC **S** Black Nitride

Female: **M** DC53 **H** Core: 58-62 HRC, Surface: 80 HRC **S** Titanium Nitride Coated

CATALOG NUMBER	T +.00 -.05	W +.000 -.005	L +.00 -.05	C	D .003/.006 CLEARANCE PER SIDE	H +.0 -.1	S1 ±.25	S2 ±.25	SHCS
CFM08X16	8	16	46	8.8	8	92	12.5	20	M4-0.7 X 10
CFM12X20	12	20	66	12.8	12	132	18.5	30	M6-1.0 X 14

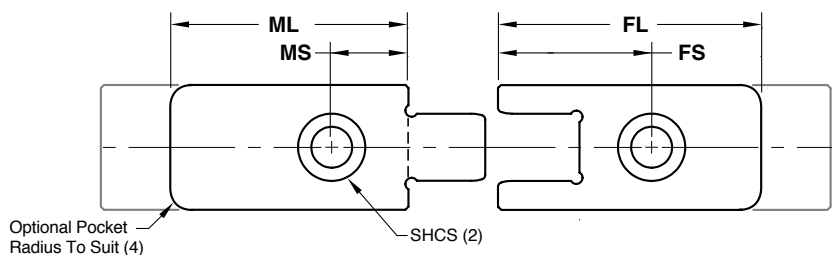
Screws included.

ALTERNATIVE CONFIGURATIONS AVAILABLE

- To order Shuttle Mold sets or special male/female configurations, refer to page C-11.
- Progressive can supply Mold-Ready Flat Cavity Interlocks complete with screw hole locations and lengths modified to suit your application. To order, specify the item code that will be modified from the charts above and provide the following to Customer Service. Note: Minimum order quantity is 2 sets of locks.
 - ML=Male Length (Must be less than "L" above.)
 - MS=Male Screw Location (Will be on center.)
 - FL=Female Length (Must be less than "L" above.)
 - FS=Female Screw Location (Will be on center.)
 - Pocket Radius: If required, add "-R" to the specification. (Radius is designed to suit Interlock size.)

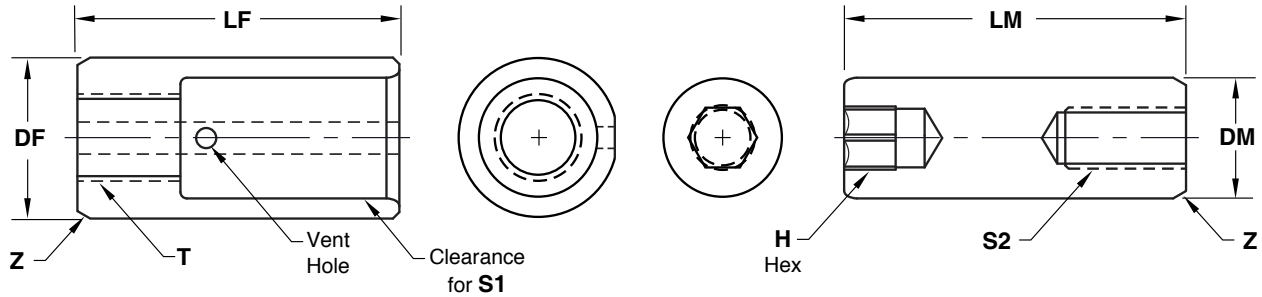
Note: Screw size will be the same as within the standards.

Any specifications outside of the modifications above can be quoted made-to-order by contacting tech@procomps.com.





CAVITY INTERLOCKS ROUND SERIES



Female: **M** H-13 **H** Core: 42-48 HRC, Surface: 70 HRC **S** Black Nitride

Male: **M** DC53 **H** Core: 58-62 HRC, Surface: 80 HRC **S** Titanium Nitride Coated

Inch Standard

CATALOG NUMBER	DM -.0001 -.0002	DF +.0000 -.0002	LF +.000 -.002	LM +.000 -.002	PM	E	Z	S1 SHCS SIZE	T	S2 SET SCREW SIZE	H
CRS250	.2500	.3750	.687	.812	.500	.23	.03	#6-32 x 3/8	#10-32	#6-32 x 1/2	1/8
CRS375	.3750	.5000	1.000	1.062	.625	.36	.04	#10-32 x 5/8	1/4-20	#10-32 x 5/8	3/16
CRS500	.5000	.6250	1.375	1.375	.750	.51	.04	1/4-20 x 7/8	5/16-18	1/4-20 x 3/4	3/16

Socket Head Cap Screw & Set Screw included.

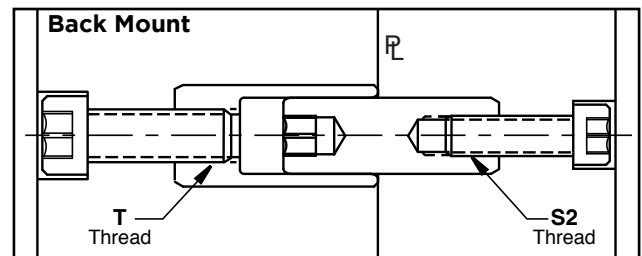
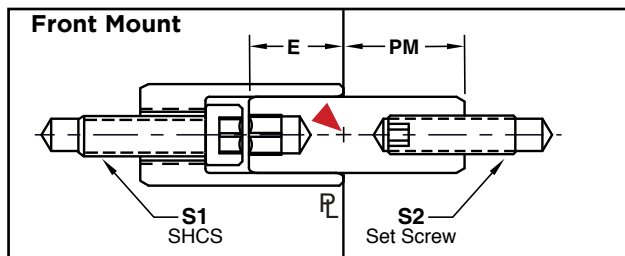
Female: **M** H-13 **H** Core: 42-48 HRC, Surface: 70 HRC **S** Black Nitride

Male: **M** DC53 **H** Core: 58-62 HRC, Surface: 80 HRC **S** Titanium Nitride Coated

Metric Standard

CATALOG NUMBER	DM -.002 -.006	DF +.000 -.005	LF +.0 -.1	LM +.0 -.1	PM	E	Z	S1 SHCS SIZE	T	S2 SET SCREW SIZE	H
CRSM06	6	8	16	18	10	6	.3	M3-0.5 x 8	M4-0.7	M4-0.7 x 12	3
CRSM08	8	12	20	24	14	8	.3	M4-0.7 x 10	M5-0.8	M5-0.8 x 16	4
CRSM10	10	14	22	26	14	10	.3	M4-0.7 x 10	M5-0.8	M6-1.0 x 16	5
CRSM12	12	16	30	32	17	13	.5	M6-1.0 x 16	M8-1.25	M6-1.0 x 16	5

Socket Head Cap Screw & Set Screw included.



APPLICATION GUIDELINES

- Interlocks Can be mounted from parting line or bolted from the back of the inserts.
- Vent hole and flat provided on female insert.
- Maximum clearance between female and male insert is .0006" / .015mm total.
- Diameter (DF & DM) Machining Tolerances: Inch: +.0002" / Metric: +.005mm
- Maximum chamfer size should be .02"/.5mm on counterbore.
- The fasteners provided are for parting line installation shown in the graphic above left. For bolting in back, select fasteners to accommodate insert thickness.
- When installing, limit torque specifications according to the chart at right.

CATALOG NUMBER	TORQUE
CRS250 CRSM06	25 IN LB
CRS375	75 IN LB
CRS500	195 IN LB
CRSM08	58 IN LB
CRSM10 CRSM12	140 IN LB

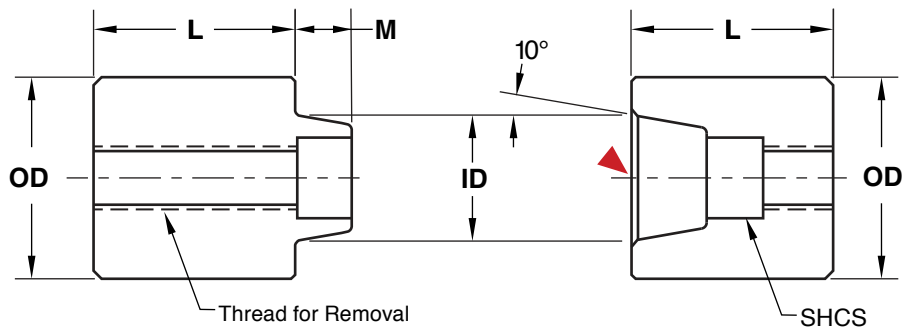
ALTERNATIVE CONFIGURATIONS AVAILABLE

- To order Shuttle Mold sets or special male/female configurations, refer to page C-11.

▶ CAD insertion point

TAPER LOCKS

COUNTERBORED STYLE



Male: **M** DC53 **H** Core: 58-62 HRC, Surface: 80 HRC **S** Titanium Nitride Coated

Female: **M** H-13 **H** Core: 42-48 HRC, Surface: 70 HRC **S** Black Nitride

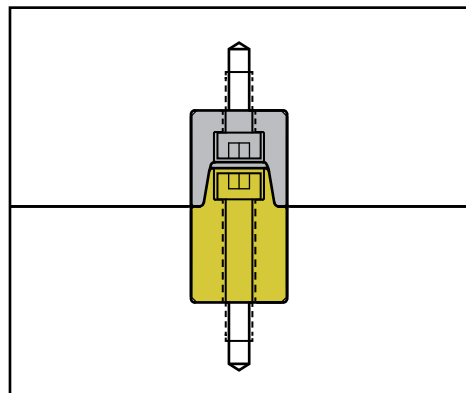
CAD insertion point

CATALOG NUMBER	OD +.0000 -.0003	ID	M	THREAD SIZE	L +.004 +.008	SHCS	
TLC50	.5000	.375	.200	#10-32	.500	M: #6-32 x 3/4	F: #6-32 x 5/16
TLC75	.7500	.500	.250	1/4-20	.750	M: #10-32 x 1-1/8	F: #10-32 x 1/2
TLC100	1.0000	.625	.343	5/16-18	1.000	M: 1/4-20 x 1-1/2	F: 1/4-20 x 3/4
TLC150	1.5000	1.000	.500	3/8-16	1.250	M: 5/16-18x 2	F: 5/16-18x 7/8
TLC200	2.0000	1.500	.500	3/8-16	1.375	M: 5/16-18x 2	F: 5/16-18 x 1

Screws included.

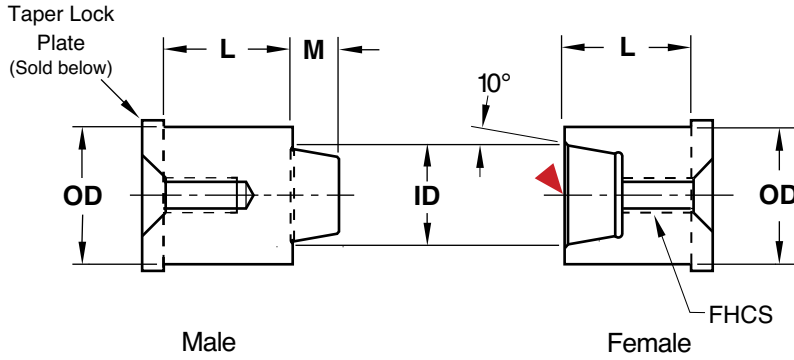
APPLICATION GUIDELINES

- Designed to be mounted and easily removed from parting line utilizing the internal thread.
- Counterbored Style Taper Locks are sold in sets. The males/ females are designed to be used in assembly and cannot be utilized with the Taper Locks shown page C-19.





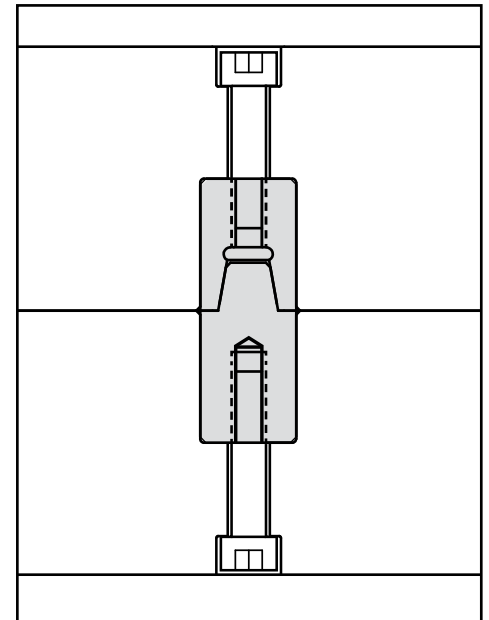
TAPER LOCKS THREADED STYLE



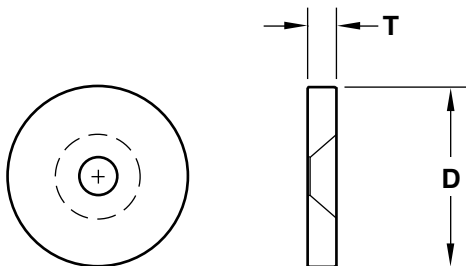
M H-13 **H** 48-52 HRC

▶ CAD insertion point

OD +.0000 -.0003	ID	M	THREAD SIZE	L +.004 +.008	MALE CATALOG NUMBER	FEMALE CATALOG NUMBER
.5000	.312	.250	#10-24	.687	MTL50L.68	FTL50L.68
				.875	MTL50L.87	FTL50L.87
				1.187	MTL50L.118	FTL50L.118
				1.375	MTL50L.137	FTL50L.137
.7500	.500	.281	1/4-20	.687	MTL75L.68	FTL75L.68
				.875	MTL75L.87	FTL75L.87
				1.187	MTL75L.118	FTL75L.118
				1.375	MTL75L.137	FTL75L.137
1.000	.625	.343	1/4-20	.687	MTL100L.68	FTL100L.68
				.875	MTL100L.87	FTL100L.87
				1.187	MTL100L.118	FTL100L.118
				1.375	MTL100L.137	FTL100L.137
1.500	1.000	.500	5/16-18	1.125	MTL150L.112	FTL150L.112
				1.375	MTL150L.137	FTL150L.137
				1.625	MTL150L.162	FTL150L.162
2.000	1.500	.500	5/16-18	1.125	MTL200L.112	FTL200L.112
				1.375	MTL200L.137	FTL200L.137
				1.625	MTL200L.162	FTL200L.162



TAPER LOCK PLATES

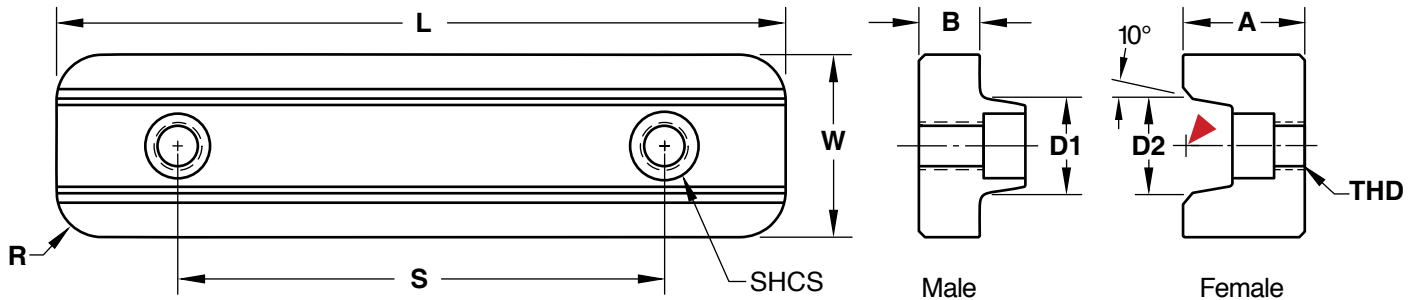


M AISI 52100 **H** 57-61 HRC **S** Black Oxide

CATALOG NUMBER	TAPER LOCK O.D.	D +.000 -.015	T +.000 -.002	FLAT HEAD COUNTERBORE
TLP50	1/2	.687	.187	#10-24
TLP75	3/4	1.000	.187	1/4-20
TLP100	1	1.187	.187	1/4-20
TLP150	1-1/2	1.687	.250	5/16-18
TLP200	2	2.187	.250	5/16-18

1/2" long FHCS included.

RECTANGULAR TAPER BAR LOCKS



Female: **M** H-13 **H** Core: 42-48 HRC, Surface: 70 HRC **S** Black Nitride

Male: **M** D-2 **H** Core: 58-62 HRC, Surface: 80 HRC **S** Titanium Nitride Coated

CAD insertion point

MALE CATALOG NUMBER	FEMALE CATALOG NUMBER	L +.000 -.005	W +.0000 -.0004	A +.001 -.000	B +.001 -.000	D1 +.0005 -.0000	D2 +.0000 -.0005	R POCKET RADIUS	S ±.01	THD
MTBL100	FTBL100	1.99	.999	.690	.312	.5400	.5398	.250	Centered	1/4-20
MTBL125	FTBL125	3.99	1.249	.870	.375	.6700	.6698	.312	2.50	5/16-18
MTBL150	FTBL150	5.99	1.499	1.000	.500	.800	.7998	.375	4.00	3/8-16

MALE CATALOG NUMBER	SHCS	FEMALE CATALOG NUMBER	SHCS
MTBL100	#10-24 x 3/4 (1)	FTBL100	#10-24 x 1/2 (1)
MTBL125	1/4-20 x 7/8 (2)	FTBL125	1/4-20 x 5/8 (2)
MTBL150	5/16-18x 1 (2)	FTBL150	5/16-18 x 3/4 (2)

Screws included.

APPLICATION GUIDELINES

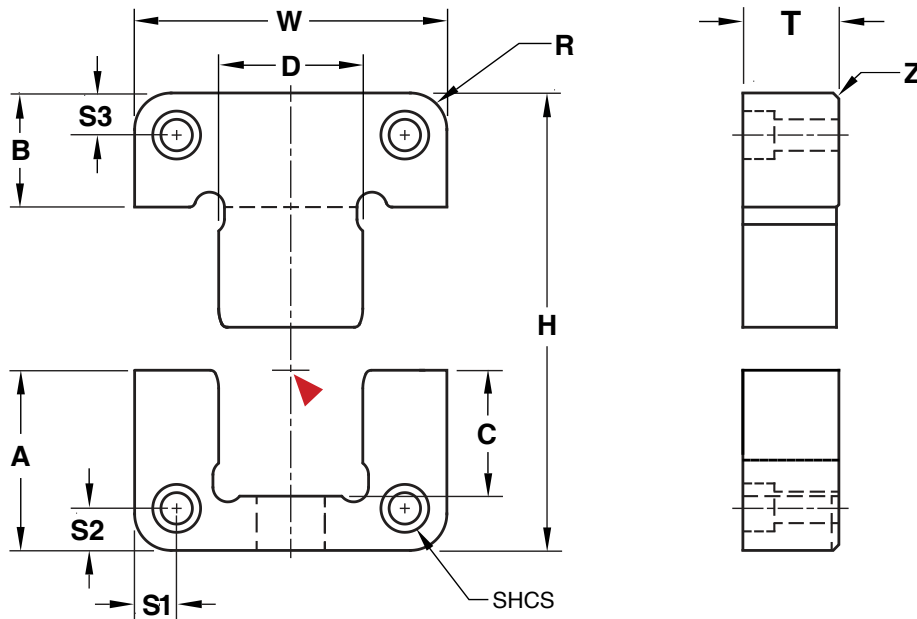
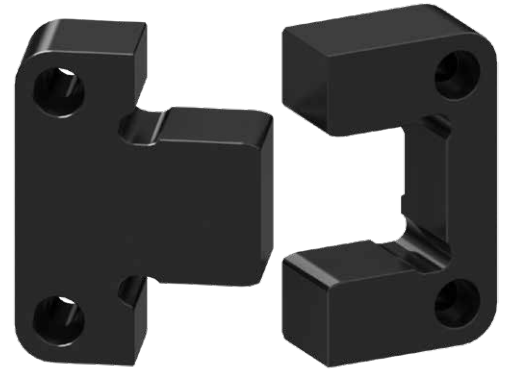
- Lock pockets should be perpendicular to insert side walls to compensate for unequal thermal expansion.
- Mounting pockets must be accurately aligned on the A-side and B-side of the mold.
- Taper Bar Locks should be fit and pre-loaded to assure metal to metal contact on taper geometry.
- The back of the Locks can be ground to adjust for pre-load.

ALTERNATIVE CONFIGURATIONS AVAILABLE

- To order Shuttle Mold sets or special male/female configurations, order the quantity of males or female inserts to suit.



SIDE LOCK
DIE CAST SERIES



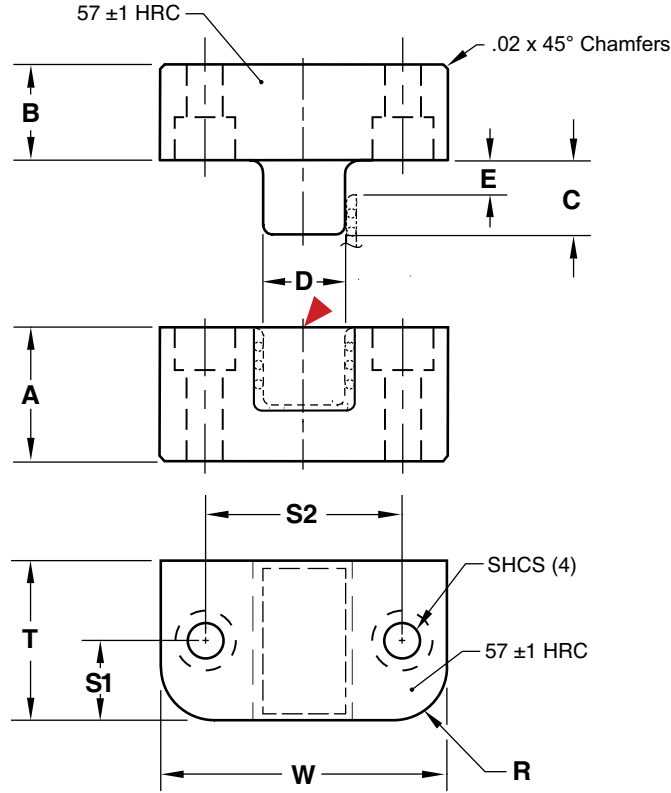
M H-13 **H** Core: 42-48 HRC, Surface: 66-70 HRC **S** Black Nitride

CAD insertion point

CATALOG NUMBER	T +.000 -.002	W +.0000 -.0004	A +.000 -.002	B +.000 -.002	C	D .0004/.001 CLEARANCE PER SIDE	H +.000 -.004	R POCKET RADIUS	S1/S2/S3 ±.01	Z	SHCS
SL200X650-BN	2.000	6.500	3.750	2.374	2.62	3.000	6.125	.750	.87	.12	5/8-11 x 2-1/4

Screws included.

TOP LOCKS
NEEDLE BEARING



Inch Standard

M O-2 **H** 56-58 HRC **S** Black Oxide

CAD insertion point

CATALOG NUMBER	T +.000 -.005	W +.0004 -.0000	W POCKET WIDTH +.0005 -.0000	A +.000 -.005	B +.000 -.005	C	D	E	S1 ±.01	S2 ±.01	R POCKET RADIUS	SHCS	
TLR87X150	.875	1.4995	1.500	1.375	.750	.66	.550	.225	.43	1.14	.250	M: #8-32 x 7/8	F: #8-32 x 1-1/2
TLR112X200	1.125	1.9995	2.000	1.375	.625	.62	.660	.425	.56	1.37	.375	M: 1/4-20 x 3/4	F: 1/4-20 x 1-1/2
TLR150X250	1.500	2.4995	2.500	1.375	.625	.62	.900	.400	.75	1.75	.375	M: 1/4-20 x 3/4	F: 1/4-20 x 1-1/2
TLR150X250-L	1.500	2.4995	2.500	1.875	.875	1.02	1.015	.350	.75	1.87	.375	M: 1/4-20 x 1	F: 1/4-20 x 2

Note: Cages are resin on all Needle Bearing Top Locks.

Screws included.

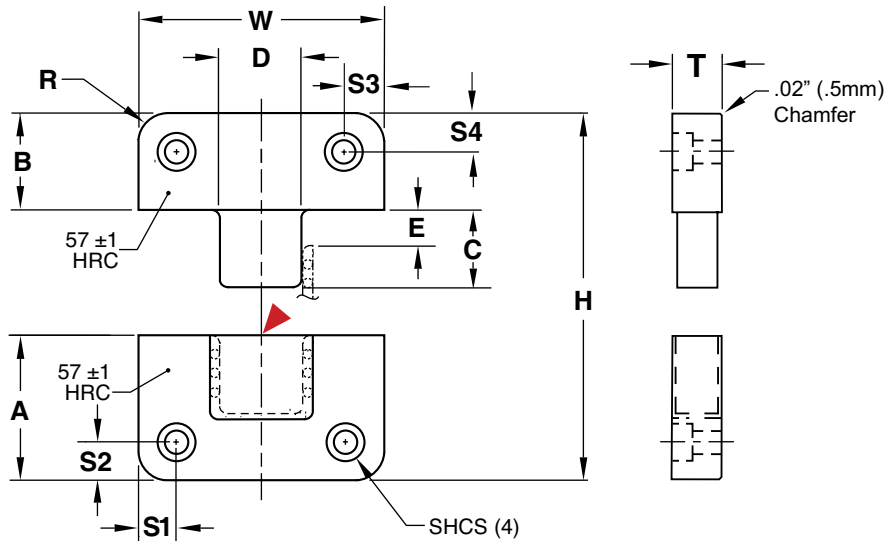
APPLICATION GUIDELINES

- Needle Bearing Locks have zero clearance between male and female (D) dimensions.
- Bearings are 64 HRC.
- Maximum Mold Temperature: 300°F (150°C)
- Engagement occurs at E dimension shown.
- Locks are to be mounted in the mold base and not in the core or cavity inserts.
- For optimal performance, pockets are to be machined to nominal "W" pocket width dimensions in each table. If replacing locks in existing pockets, ensure .0004" clearance, and the lock may be modified to suit.
- As with other mold mechanisms, clean and maintain locks at the mold's scheduled PMs.





SIDE LOCKS NEEDLE BEARING



▶ CAD insertion point

M O-2 **H** 56-58 HRC **S** Black Oxide

Inch Standard

CATALOG NUMBER	T +.000 -.005	W ±.0002	W POCKET WIDTH +.0005 -.0000	A +.000 -.005	B +.000 -.005	C	D	E	H +.000 -.004	R POCKET RADIUS	S1 ±.01	S2 ±.01	S3 ±.01	S4 ±.01	SHCS
SLR50X125	.500	1.2495	1.250	1.375	.875	.66	.412	.210	2.250	.187	.17	.25	.17	.43	#8-32 x 5/8
SLR50X150	.500	1.4995	1.500	.875	.875	.40	.500	.210	1.750	.187	.25	.25	.25	.25	#8-32 x 5/8
SLR50X150-L	.500	1.4995	1.500	1.375	.875	.66	.550	.250	2.250	.187	.18	.37	.18	.50	#8-32 x 5/8
SLR50X200	.500	1.9995	2.000	1.375	.875	.66	.750	.325	2.250	.187	.31	.31	.31	.31	#10-32 x 5/8
SLR75X300	.750	2.9995	3.000	1.875	.875	.95	1.188	.575	2.750	.250	.37	.37	.37	.37	1/4-20 x 3/4
SLR100X400	1.000	3.9995	4.000	2.375	1.375	1.34	1.855	.450	3.750	.500	.50	.50	.50	.50	3/8-16 x 1-1/8

For application guidelines, refer to page C-22.

Screws included.

Note: Cages are manufactured from resin on all sizes except SLR100X400, which has an aluminum cage.

M O-2 **H** 56-58 HRC **S** Black Oxide

Metric Standard

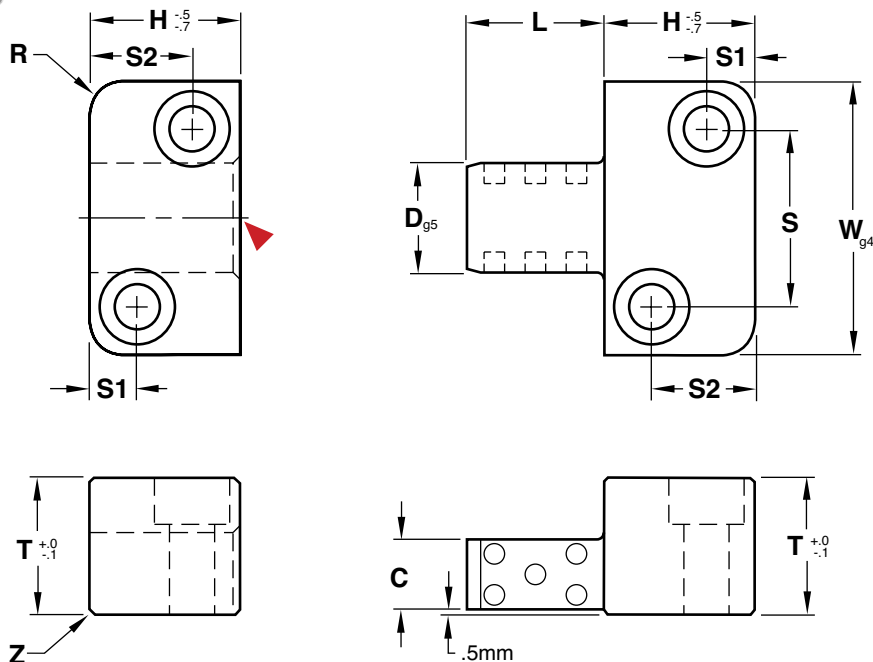
CATALOG NUMBER	T +.00 -.12	W ±.005	W POCKET WIDTH +.012 -.000	A +.00 -.12	B +.00 -.12	C	D	E	H +0.0 -0.1	R POCKET RADIUS	S1 ±.25	S2 ±.25	S3 ±.25	SHCS
SLRM32X63	32	62.9	63	46	46	27	21	12.1	92	8	9	11	35	M8-1.25 x 35
SLRM40X100	40	99.9	100	66	66	36	33	19.5	132	10	13	18	48	M12-1.75 x 45

For application guidelines, refer to page C-22.

Screws included.

Note: Cages are manufactured from aluminum on all sizes of metric standard locks.

SIDE LOCKS
GRAPHITE PLUGGED



Metric Standard

M O-2 **H** 56-60 HRC

CAD insertion point

CATALOG NUMBER	L	D	T	W	C	H	S1	S2	S	R	Z	SHCS
SLPM16X20	20	16	20	40	11	22	7	15	26	6	1	M6-1.0 x 25
SLPM16X40	40											
SLPM20X25	25	20	22	45	13	27	7	19	31	6	1	M6-1.0 x 25
SLPM20X50	50											
SLPM25X32	32	25	25	50	14	36	9	27	35	8	1	M6-1.0 x 30
SLPM25X63	63											
SLPM32X40	40	32	32	63	19	46	11	35	45	8	1	M8-1.25 x 35
SLPM32X80	80											
SLPM40X50	50	40	36	85	22	56	15	40	60	10	1.5	M10-1.5 x 40
SLPM40X100	100											
SLPM50X56	56	50	40	100	24	66	18	48	74	10	1.5	M12-1.75 x 45
SLPM50X112	112											

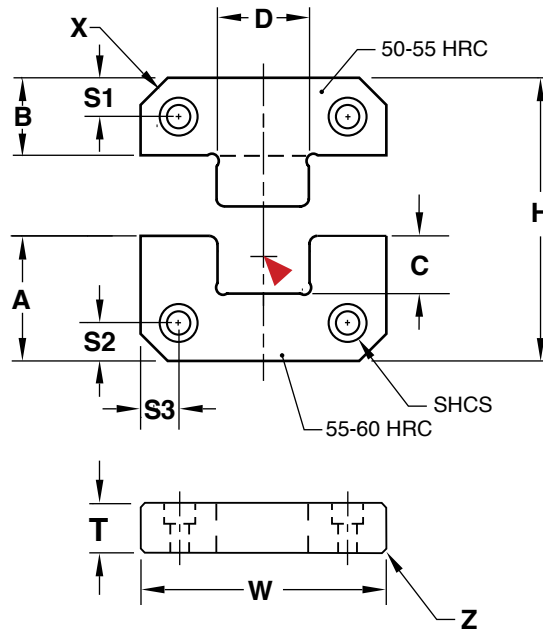
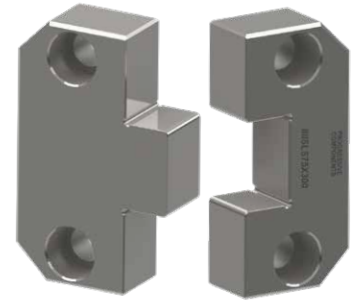
Screws included.

APPLICATION GUIDELINES

- Using grease will inhibit the function of the graphite plugs. Instead, use a light 20 weight oil at startup to begin lubrication.



SIDE LOCKS



M O-2 **H** 55-60 HRC

Inch Standard

CATALOG NUMBER	T +.000 -.002	W +.0000 -.0004	A +.0000 -.0008	B +.0000 -.0008	C	D .0001/.0003 CLEARANCE PER SIDE	H +.000 -.002	X CORNER CHAMFER	Z CHAMFER	S1 ±.01	S2 ±.01	S3 ±.01	SHCS
SLS62X150	.620	1.500	.870	.870	.33	.500	1.74	.19	.02	.43	.28	.28	1/4-20 x 3/4
SLS62X200	.620	2.000	.870	.870	.33	.680	1.74	.19	.04	.43	.37	.37	1/4-20 x 3/4
SLS75X300	.745	3.000	1.370	1.360	.57	1.000	2.73	.38	.04	.68	.68	.37	3/8-16 x 1
SLS75X400	.745	4.000	1.870	1.870	.79	1.375	3.74	.50	.04	.87	.87	.62	3/8-16 x 1
SLS112X500	1.120	5.000	1.870	1.870	.79	1.750	3.74	.50	.04	.87	.87	.75	1/2-13 x 1-1/4

▶ CAD insertion point

Screws included.

Metric Standard

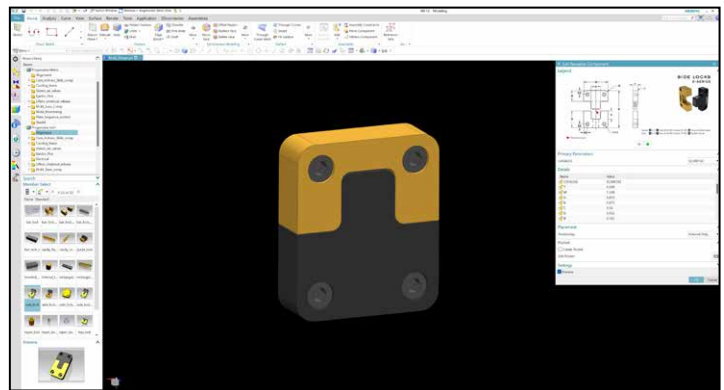
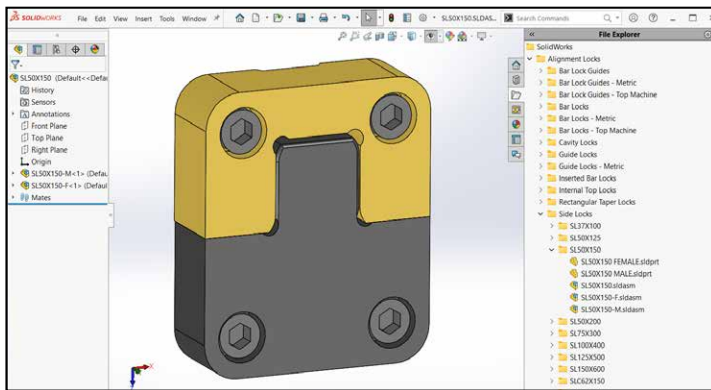
CATALOG NUMBER	T +.00 -.05	W +.00 -.01	A +.00 -.02	B +.00 -.02	C	D .002/.008 CLEARANCE PER SIDE	H +.00 -.04	X CORNER CHAMFER	Z CHAMFER	S1/S2 ±.25	S3 ±.25	SHCS
SLMS13X38	13	38	22	22	8.5	12	44	5	.5	7	8	M5-.8 x 15
SLMS16X50	16	50	21.5	21.5	9.5	17	43	5	1	11	8	M6-1.0 x 18
SLMS19X75	19	75	36	36	15	25	72	8	1	18	12.5	M10-1.5 x 20
SLMS19X100	19	100	45	45	21	35	90	10	1	22	15	M10-1.5 x 20
SLMS25X125	25	125	45	45	21	45	90	10	1	22	20.5	M10-1.5 x 25

Screws included.

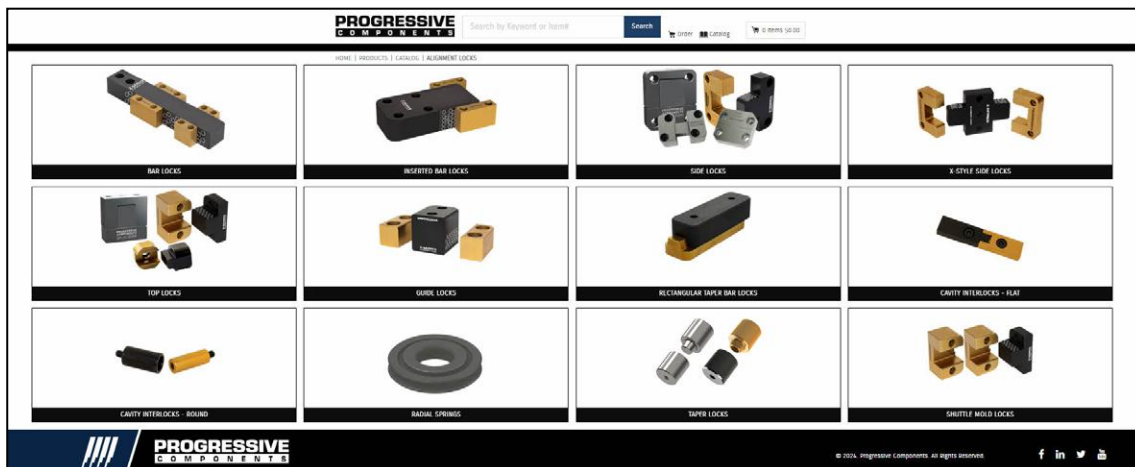
ONLINE RESOURCES



When considering design options, numerous animations can be viewed at procomps.com/animations.



CAD geometry is available online as individual downloads or as part of the CADalog system. The seven formats include: IGES (.igs), ACIS (.sat), STEP (.step), Parasolid (.x_t), SolidWorks (.sldasm), NX (.prt) (Re-Use and MoldWizard) and Visi (.wfk).



Industry-leading web store expedites the purchasing process. Go to shop.procomps.com for information and additional resources.



CAVITY COMPONENTS, DATE MARKING

SECTION D



Runner Turn Off	Gate Inserts	Locking Series	Remains Flush (RF) Series
Prefix: RT	Prefix: GT	Prefix: DN, DTN	Prefix: DF
Pages: D-2 & D-3	Page: D-4 & D-5	Pages: D-6 & D-7	Page: D-8



Tapered Series	Compact Height (CH) Series	20 Series (20mm)	Deep (D) Series
Prefix: DTPR	Prefix: DC	Prefix: DL	Prefix: DL Suffix:-D
Page: D-9	Page: D-10	Page: D-11	Page: D-11



Multi-Daters	Full Diameter (FD) Series	Replacement Plugs	MicroDaters
Prefix: DMD	Prefix: DFD	Prefix: DP, DXP	Prefix: MD
Page: D-12	Page: D-13	Page: D-14	Page: D-15



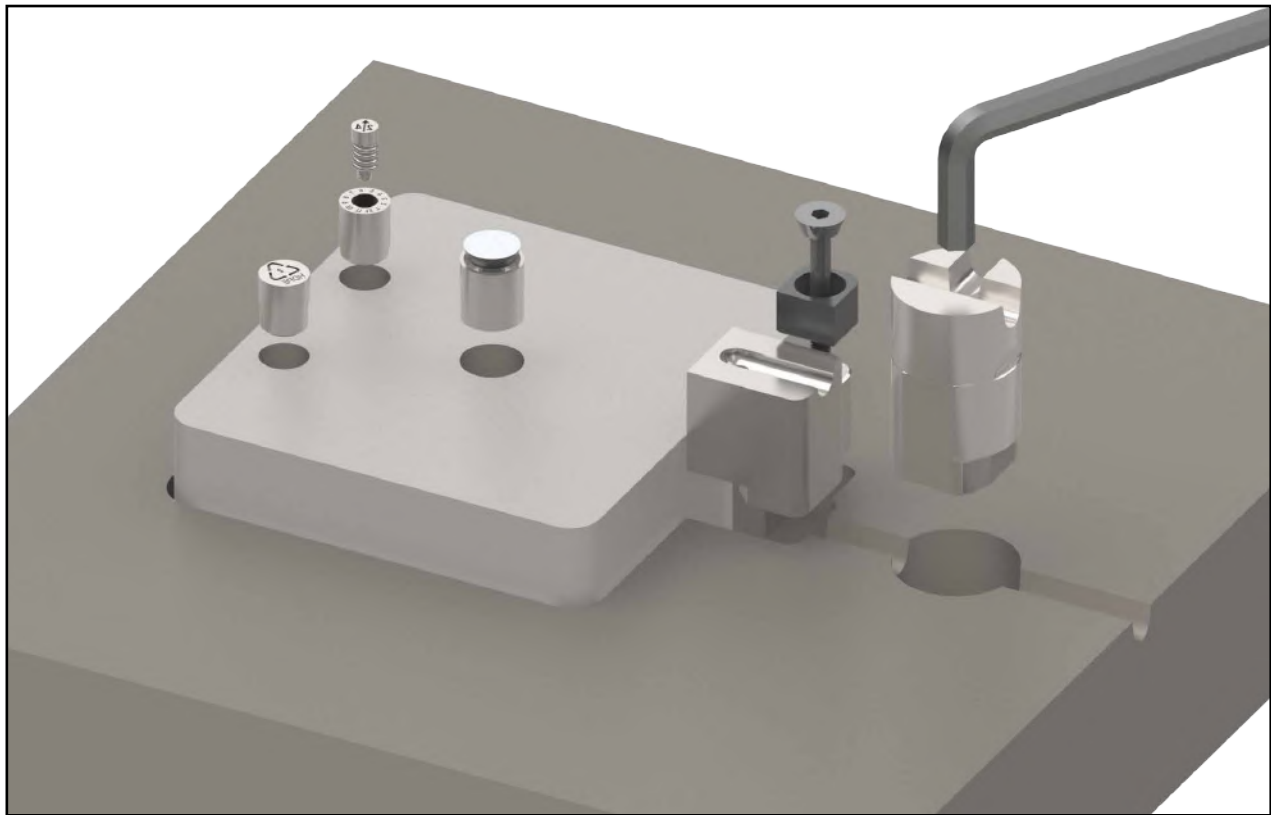
LG Series	Recycle Inserts	Air Poppets	Air Valves
Prefix: DLB, DLS	Prefix: RI	Prefix: APV	Prefix: AV
Page: D-16	Page: D-17	Page: D-18	Page: D-19



OVERVIEW

Progressive offers the widest range of Daters in the industry, while also providing cavity components for a variety of applications:

- With reliable click-in-place positioning at 45° increments, Runner Turn Offs are available in styles with and without a center ejector pin as shown on page D-2.
- Gate Inserts allow for modifications from parting line when abrasive materials open gates, shown on page D-4.
- Recycle Inserts that are available in both ASTM and SPI standards can be found on page D-17.
- Air Valves and Air Poppets are offered in both inch and metric, shown on page D-18.



ONLINE DATA

PROGRESSIVE COMPONENTS

ABOUT • PRODUCTS • MONITORING • MAINTENANCE • RESOURCES • NEWS • CONTACT

NEW PRODUCT RELEASE

Recent Releases Components and Technology Solutions from Progressive

ANGLE PINS & ANGLE PIN HOLDERS

Designed to simplify the installation of angle pins, Progressive's **Angle Pin Holder** conveniently inserts and locks in place, reducing handling during line set-up and rework. Progressive's standard Angle Pin Holders allow additional machining options: available in one- and two-lead thread that allows users to machine 10°, 15°, or 20° angles. Also, have larger tools, are 1" diameter Angle Pins, and are used in Angle Pin Holders.

COUNTERBORED ROUND TAPER LOCKS

Mounted from the mold's parting line, the new **Counterbored Round Taper Locks** are available in a single file size from 1/2" to 1 1/2" diameters. This advanced standard in the industry only Taper Lock featuring Progressive's proprietary materials and treatment.

Learn more about the latest releases at procomps.com/new.

CAVITY COMPONENTS, DATE MARKING

DATE STAMPS REPLACEMENT PLUGS

Refer to the catalog pages for the specific series required for plugs with alternate engraving such as "ICE", "Arrow Only", or raised versions. Contact Customer Service for availability of alternate plugs or for verification of the plugs required in your application.

LOCKING SERIES		TAPERED SERIES		COMPACT LOCKING		RF SERIES	
CATALOG NUMBER	DATE MARKING	CATALOG NUMBER	DATE MARKING	CATALOG NUMBER	DATE MARKING	CATALOG NUMBER	DATE MARKING
SNP02-24	DN02	ETP002-24	DT002	DTM02-24	DTM02	DF002-24	DF02
SNP02-24	DN02	ETP002-24	DT002	DTM02-24	DTM02	DF002-24	DF02
SNP02-24	DN02	ETP002-24	DT002	DTM02-24	DTM02	DF002-24	DF02
SNP02-24	DN02	ETP002-24	DT002	DTM02-24	DTM02	DF002-24	DF02
SNP02-24	DN02	ETP002-24	DT002	DTM02-24	DTM02	DF002-24	DF02
SNP02-24	DN02	ETP002-24	DT002	DTM02-24	DTM02	DF002-24	DF02
SNP02-24	DN02	ETP002-24	DT002	DTM02-24	DTM02	DF002-24	DF02
SNP02-24	DN02	ETP002-24	DT002	DTM02-24	DTM02	DF002-24	DF02
SNP02-24	DN02	ETP002-24	DT002	DTM02-24	DTM02	DF002-24	DF02

CH, D, & 20 SERIES To replace Progressive's CH, D, & 20 Series plugs

MULTI-DATERS To replace Progressive's Multi-Dater plugs

RETRO PLUGS To replace plugs previously purchased for PCCT™

INDEXABLE PLUGS To replace plugs previously purchased for ICE™

All catalog pages are online for forwarding to colleagues.

DATE STAMPS

PROGRESSIVE COMPONENTS

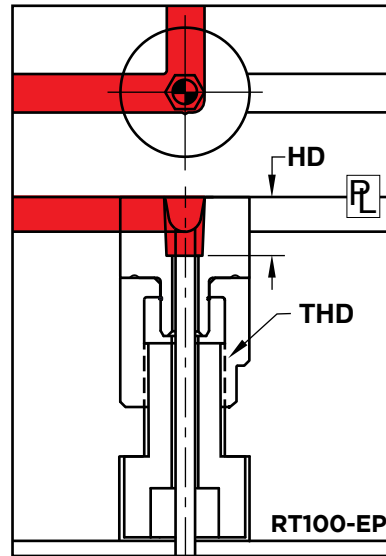
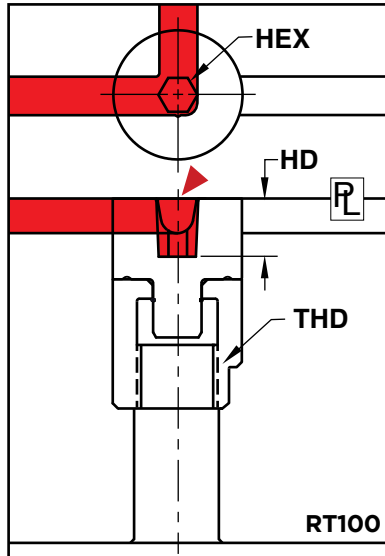
Numerous animations can be viewed at procomps.com.

RUNNER TURN OFF



APPLICATION GUIDELINES

- Runner Turn Off inserts provide a reliable position of material flow.
- Hex with 2° taper provided for rotating insert.
- Runner Turn Offs utilize detents positioned in 45° increments.
- Machining is straightforward with two flats provided on top and bottom rings to hold in place without risk of spinning.
- Press fit (PF) is provided for orientation during installation.
- Recommended runner guidelines are provided on the following page.
- RT100-EP is supplied with 5/8-11 x 2" SHCS. Modify the length to suit.
- For removal, a spare 5/8-11 bolt must be used to strike from back in order to overcome the press fit.

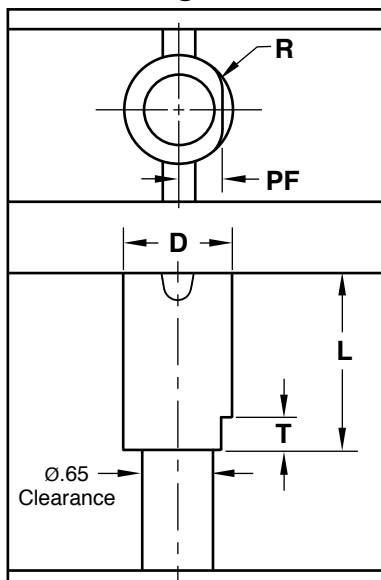


M 420 Stainless **H** 30-34 HRC

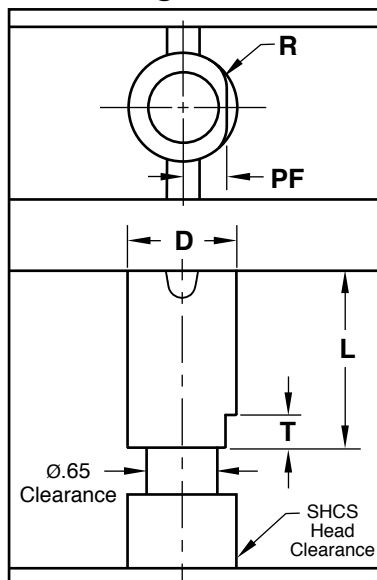
CATALOG NUMBER	EJ PIN SIZE	D	L	T	R	PF	HEX	HD HEX DEPTH	THD
RT100	-	1.000	1.625	.300	.312	.400	1/4	.45	5/8-11
RT100-EP	3/16								

▶ CAD insertion point

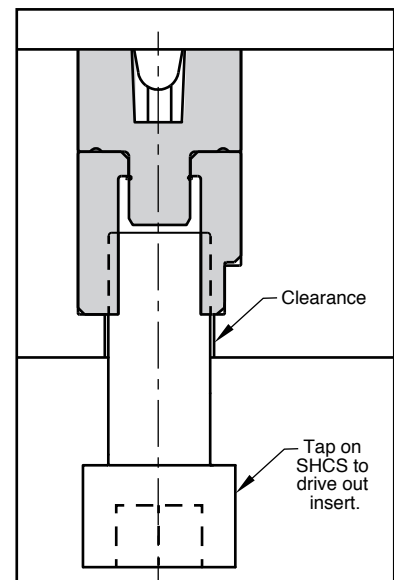
Machining for RT100



Machining for RT100-EP



Removal

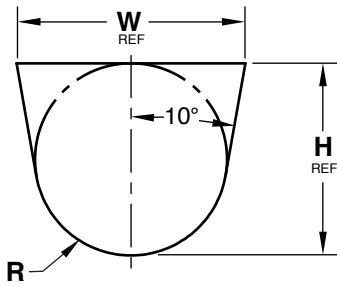
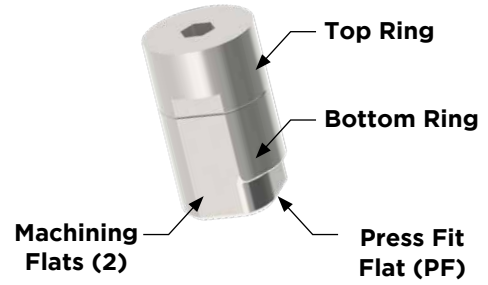




RUNNER TURN OFF

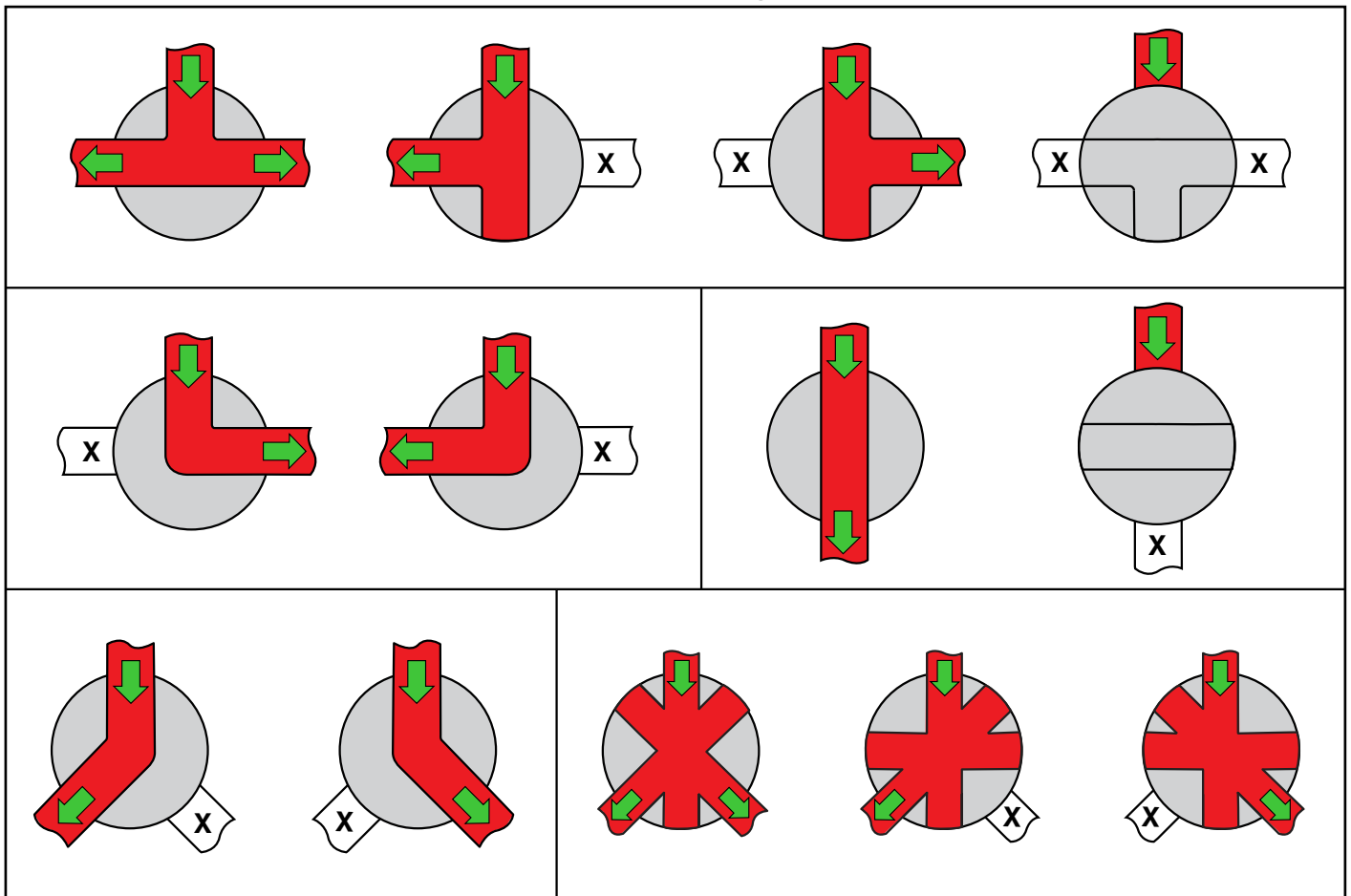
RUNNER MACHINING GUIDELINES

- Runner Turn Offs have two machining flats to prevent spinning when holding the assembly in a vise.
- Refer to the table below for recommended runner geometry.
- Maximum machining depth (H) is .313.

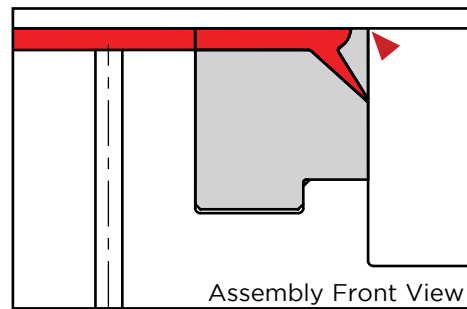
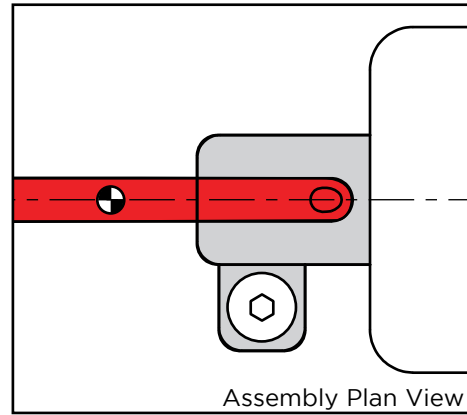
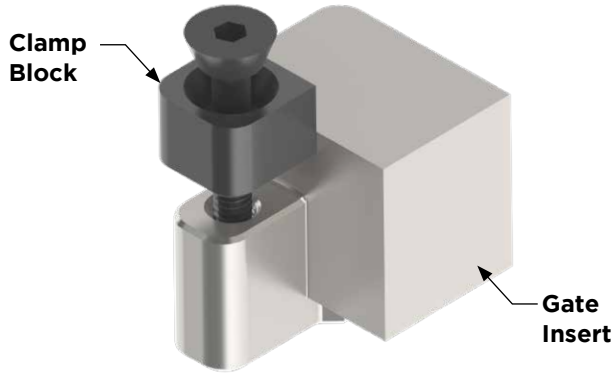


RUNNER SIZE	H	R	W	AREA (SQ. INCH)
3/32	.094	.047	.112	.008
1/8	.125	.063	.149	.015
5/32	.156	.078	.186	.023
3/16	.188	.094	.223	.033
7/32	.219	.109	.261	.045
1/4	.250	.125	.298	.059
9/32	.281	.140	.335	.075
5/16	.313	.156	.372	.092

Possible Runner Configurations



GATE INSERTS



PART NAME	MATERIAL/TREATMENT
Gate Insert	Uddeholm Caldie®, 56-60 HRC
Clamp Block	4140, 28-32 HRC, Black Oxide

▶ CAD insertion point

CATALOG NUMBER	W1	W2	L	A	B	R	D	E	S1	S2	THD
GT75	.750	1.250	1.000	.375	.875	.130	.875	1.063	.625	.625	#8-32

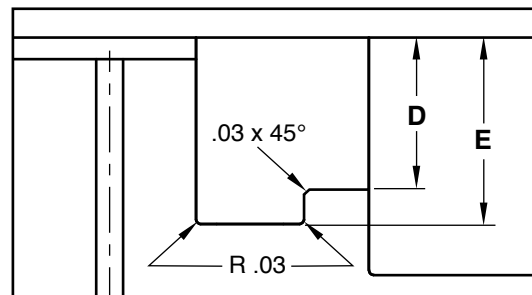
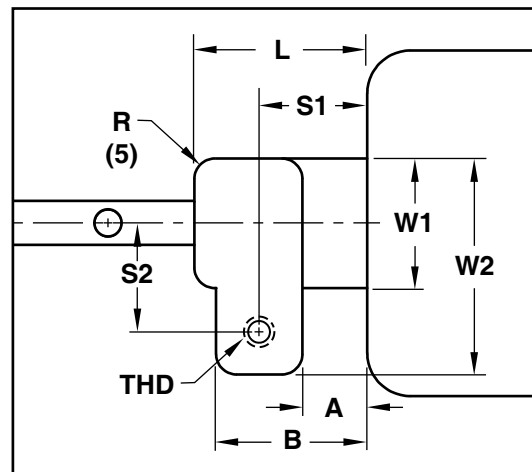
Assembly includes Gate Insert, Clamp Block, and Screw.

APPLICATION GUIDELINES

- Gate Inserts are designed for performance when running abrasive materials.
- Serviceable from parting line.
- The GT75 is designed for use when gate size is known. If unknown and adjustments are likely, consider the GT75-S on the opposite page for modifications without requiring re-EDM'ing of the gate.
- Fitting stock is included on both this insert and the insert on the next page:

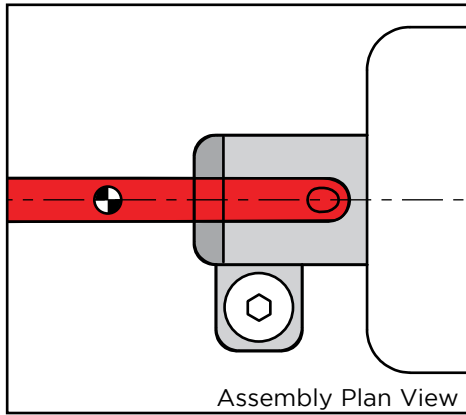
$L = +.010"/+.012"$

$D = +.005"/+.007"$

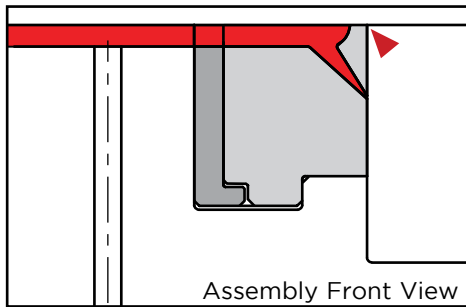




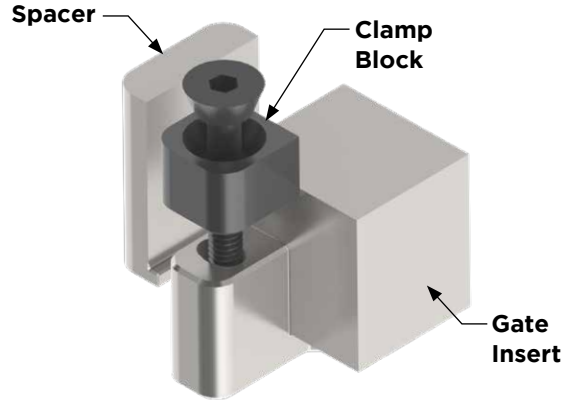
GATE INSERTS ADJUSTABLE SPACER DESIGN



Assembly Plan View



Assembly Front View

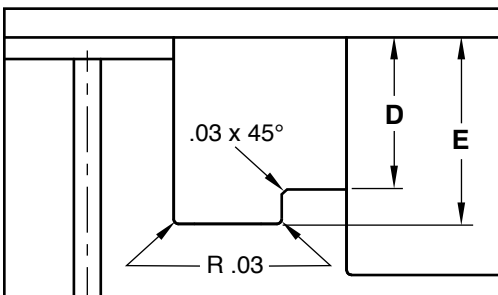
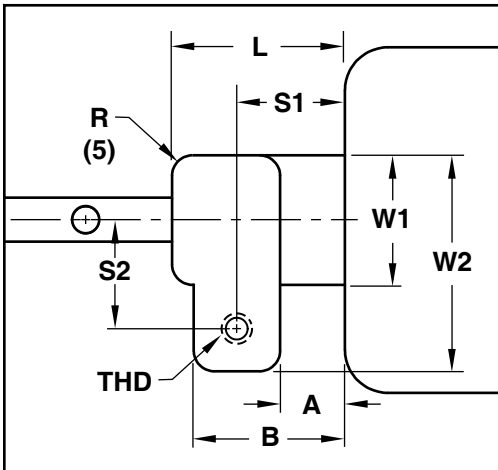


PART NAME	MATERIAL/TREATMENT
Gate Insert	Uddeholm Caldie®, 56-60 HRC
Clamp Block	4140, 28-32 HRC, Black Oxide
Spacer	DH2F, 37-41 HRC

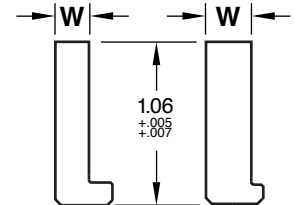
CAD insertion point

CATALOG NUMBER	W1	W2	L	A	B	R	D	E	S1	S2	THD
GT75-S	.750	1.250	1.000	.375	.875	.130	.875	1.063	.625	.625	#8-32

Assembly includes Gate Insert, Clamp Block, and Screw.



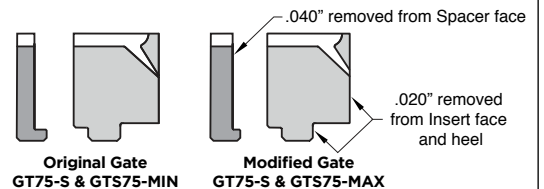
SPACER CATALOG NUMBER	W
GTS75-MIN	.175
GTS75-MAX	.235



APPLICATION GUIDELINES

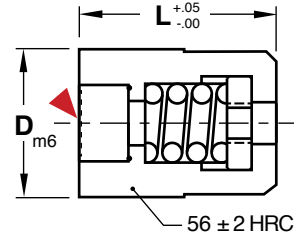
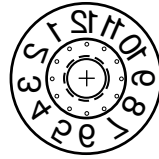
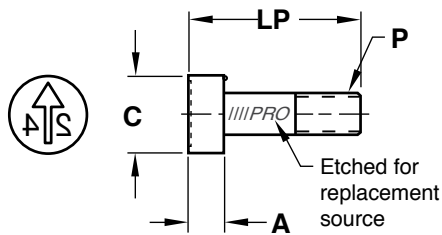
- The GT75-S is designed for use in applications where the gate size is unknown and adjustments are likely.
- Rather than re-EDM'ing the gate to open the diameter, material can be removed from the front/cavity face of the Gate Insert.
- Spacers are sold separately and are required when using the GT75-S:
 - The GTS75-MIN offers no stock for adjustment and would be utilized when gate modifications are not yet known.
 - The GTS75-MAX includes .060" stock for modification when up to .060" of stock is removed from the Gate Insert GT75-S.
- Remove stock from the front face and the front heel (shown below). Then subtract .060" from what was removed from those two surfaces, and remove that result from the Spacer. Then re-sample the mold.

Example: First, the mold was sampled with the GT75-MIN Spacer. After deciding to open the gate, .020" was removed from the front face and heel of the Gate Insert GT75-S. Then, .040" was removed from the GTS75-MAX Spacer face (.060"-.020"=.040") to fit within the original pocket.



DATE STAMPS

COMPACT LOCKING DETENT SERIES



PLUGS



M 420 Stainless (1.4034) **H** 54-58 HRC

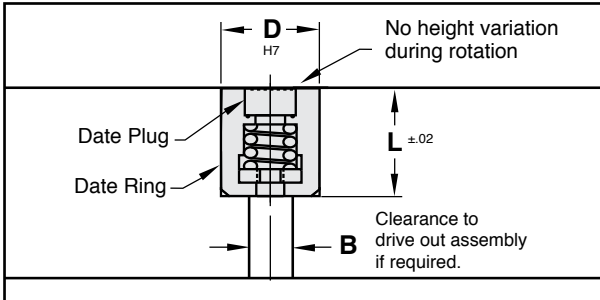
CATALOG NUMBER	C	A	LP	P	ENGRAVING DEPTH (ARROW)
DTNP03-24	1.6	1.0	3.8	M1 x 0.25	.20
DTNP04-24	2.5	1.2	4.8	M1.4 x 0.2	.30
DTNP05-24	3.1	2.0	7.8	M1.6 x 0.2	.40
DTNP06-24	3.1	2.0	7.8	M1.6 x 0.2	.40
DTNP08-24	4.4	2.5	9.8	M2.3 x 0.25	.40
DTNP10-24	5.2	3.0	11.8	M2.5 x 0.35	.40
DTNP12-24	6.2	3.0	13.8	M3 x 0.35	.60
DTNP16-24	8.2	3.5	13.8	M4 x 0.35	.60
DTNP20-24	11.0	4.5	15.8	M4 x 0.35	.60

RINGS



▶ CAD insertion point

CATALOG NUMBER	D	L	B MAX FROM GRAPHIC BELOW	ENGRAVING DEPTH
DTN03	3	4	1.6	.10
DTN04	4	5	2.2	.15
DTN05	5	8	3.2	.20
DTN06	6	8	3.2	.20
DTN08	8	10	4.2	.20
DTN10	10	12	5.2	.20
DTN12	12	14	6.2	.25
DTN16	16	14	8.2	.25
DTN20	20	16	10.2	.30



To Order:

- Specify catalog number as shown above and below for the different style plugs and rings.
- Where years are specified (*), any year can be ordered by changing the suffix. Example: DTNP05-25 or DTNY05-26.
- To create Date Stamps for days, purchase both the 0-30 ring (DNT) and the 0-9 ring (DNN) and the desired plugs.
- Special configurations are available. Contact Customer Service for more information.

Plug Styles: Recessed Lettering

Arrow Only
Cat #: DTNP-Diam-AO
Ex.: DTNP05-AO

C
Cat #: DTNP-Diam-C
Ex.: DTNP05-C

Ring Styles: Recessed Lettering

0 - 9
Cat #: DTNN-Diam
Ex.: DTNN05

0 - 30
Cat #: DTNT-Diam
Ex.: DTNT05

Blank
Cat #: DTN-Diam-B
Ex.: DTN05-B

A - L
Cat #: DTNA-Diam
Ex.: DTNA05

M - X
Cat #: DTNZ-Diam
Ex.: DTNZ05

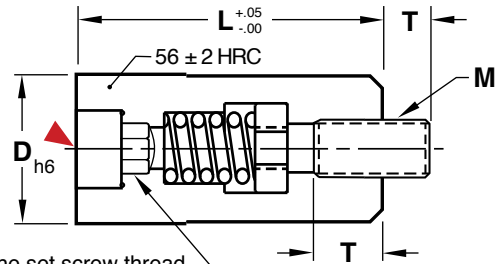
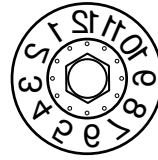
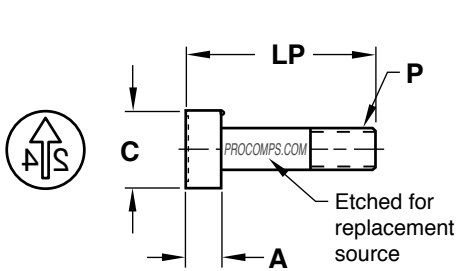
Years
Cat #: DTNY-Diam-Starting Year*
Ex.: DTNY05-24

APPLICATION GUIDELINES

- Maximum molding pressure: 20,000 psi/2,000 bar.
- Maximum mold temperature: Ø3-Ø4mm: 662°F (350°C) / Ø5-Ø20mm: 932°F (500°C)



DATE STAMPS LOCKING DETENT SERIES



Hex is present for tightening the set screw thread from parting line when plug is not installed.

PLUGS



M 420 Stainless (1.4034) **H** 54-58 HRC

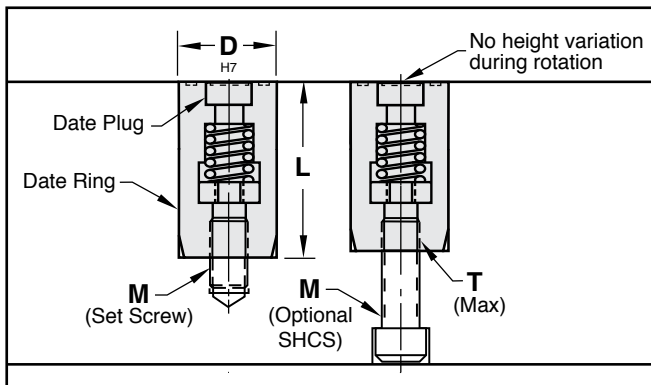
CATALOG NUMBER	C	A	LP	P	ENGRAVING DEPTH (ARROW)
DNP03-24	1.6	2.2	9.0	M1 x 0.25	.20
DNP04-24	2.5	2.3	10.5	M1.4 x 0.2	.30
DNP05-24	3.1	2.8	13.0	M1.6 x 0.2	.40
DNP06-24	3.1	2.8	13.0	M1.6 x 0.2	.40
DNP08-24	4.6	4.0	14.0	M2.5 x 0.35	.40
DNP10-24	4.6	4.0	14.0	M2.5 x 0.35	.40
DNP12-24	6.4	4.0	17.0	M3 x 0.5	.60
DNP16-24	8.4	5.0	23.0	M3.5 x 0.6	.60

RINGS



▶ CAD insertion point

CATALOG NUMBER	D	L	M	T	ENGRAVING DEPTH
DN03	3	14	M2 x 0.4	3	.10
DN04	4	14	M2 x 0.4	3	.10
DN05	5	17	M3 x 0.5	3	.20
DN06	6	17	M3 x 0.5	3	.20
DN08	8	20	M4 x 0.7	4	.20
DN10	10	20	M5 x 0.8	4	.20
DN12	12	25	M6 x 1.0	6	.25
DN16	16	33	M8 x 1.25	8	.25



To Order:

- Specify catalog number as shown above and below for the different style plugs and rings.
- Where years are specified (*), any year can be ordered by changing the suffix. Example: DNP05-25 or DNY05-26.
- To create Date Stamps for days, purchase both the 0-30 ring (DNT) and the 0-9 ring (DNN) and the desired plugs.
- Special configurations are available. Contact Customer Service for more information.

Plug Styles: Recessed Lettering



Arrow Only

Cat #:DNP-Diam-AO
Ex.: DNP05-AO



C

Cat #:DNP-Diam-C
Ex.: DNP05-C

Ring Styles: Recessed Lettering



0 - 9

Cat #:DNN-Diam
Ex.: DNN05



A - L

Cat #:DNA-Diam
Ex.: DNA05



0 - 30

Cat #:DNT-Diam
Ex.: DNT05



M - X

Cat #:DNZ-Diam
Ex.: DNZ05



Blank

Cat #:DN-Diam-B
Ex.: DN05-B



Years

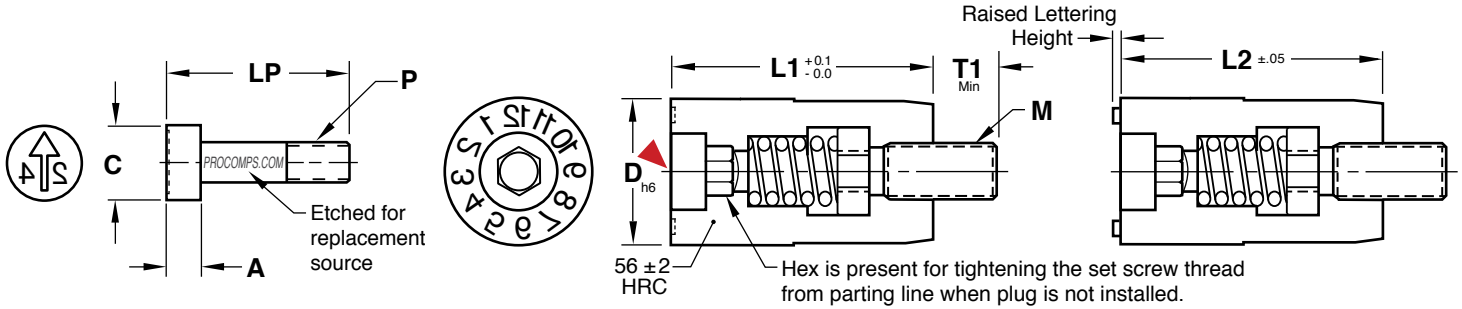
Cat #:DNY-Diam-Starting Year*
Ex.: DNY05-24

APPLICATION GUIDELINES

- Ring can be installed using the included set screw or retained with a screw from the back.
- Maximum mold temperature:
 - Ø3-Ø4mm: 662°F (350°C)
 - Ø5-Ø16mm: 932°F (500°C)

DATE STAMPS

RF SERIES: REMAINS FLUSH



PLUGS



M 420 Stainless (1.4034) **H** 54-58 HRC

RINGS



▶ CAD insertion point

RECESSED CATALOG NUMBER	C	A	LP	P	RECESSED ENGRAVING DEPTH	ENGRAVING DEPTH (ARROW)	RAISED SLOT DEPTH	RECESSED CATALOG NUMBER	D	L1 RECESSED	L2 RAISED	M	T1	T2
DFP03-24	1.6	2.0	9.0	M1 x 0.25	0.10	.30	N/A†	DF03	3	14	N/A†	M2 x 0.4	4	3†
DFP04-24	2.5	2.3	10.5	M1.4 x 0.2	0.10	.30	.25	DF04	4	14	13.80	M2 x 0.4	4	3
DFP05-24	3.1	2.8	13.0	M1.6 x 0.2	0.15	.40	.30	DF05	5	17	16.75	M3 x 0.5	4	3
DFP06-24	3.1	2.8	13.0	M1.6 x 0.2	0.15	.40	.30	DF06	6	17	16.75	M3 x 0.5	4	3
DFP08-24	4.6	4.0	14.0	M2.5 x 0.35	0.20	.40	.35	DF08	8	20	19.70	M4 x 0.7	4	4
DFP10-24	4.6	4.0	14.0	M2.5 x 0.35	0.20	.40	.35	DF10	10	20	19.70	M5 x 0.8	4	4
DFP12-24	6.4	4.0	17.0	M3 x 0.5	0.25	.60	.40	DF12	12	25	24.70	M6 x 1.0	6	6
DFP16-24	8.4	5.0	23.0	M3.5 x 0.6	0.25	.60	.40	DF16	16	33	32.70	M8 x 1.25	8	8

† 3mm size not available with raised lettering. Raised Lettering Height is equal to L1 minus L2 on each available diameter.

To Order:

- Specify catalog number as shown above and below for the different style plugs and rings.
- Where years are specified (*), any year can be ordered by changing the suffix. Example: DFP05-25 or DFY05-26.
- Special configurations are available. Contact Customer Service for more information.

APPLICATION GUIDELINES

- Ring can be installed using the included set screw or retained with a screw from the back.
- Maximum mold temperature:
 - Ø3-Ø4mm: 662°F (350°C)
 - Ø5-Ø16mm: 932°F (500°C)

Plug Styles: Recessed Lettering

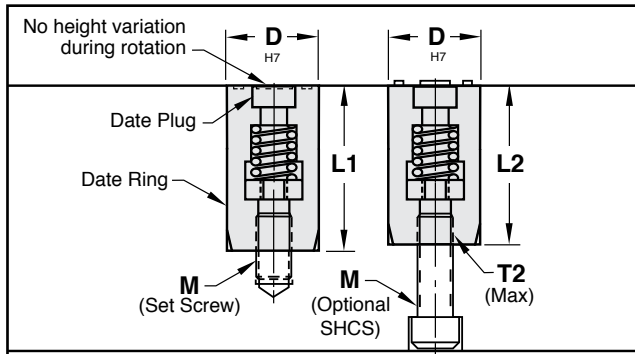
Plug Styles: Raised Lettering

Ring Styles: Recessed Lettering

- Arrow Only**
Cat #: DFP-Diam-AO
Ex.: DFP05-AO
- C**
Cat #: DFP-Diam-C
Ex.: DFP05-C

- Year**
Cat #: DFRP-Diam-Year*
Ex.: DFRP05-24
- Arrow Only**
Cat #: DFRP-Diam-AO
Ex.: DFRP05-AO
- C**
Cat #: DFRP-Diam-C
Ex.: DFRP05-C

- 0 - 9**
Cat #: DFN-Diam
Ex.: DFN05
- A - M**
Cat #: DFA-Diam
Ex.: DFA05
- N - Z**
Cat #: DFZ-Diam
Ex.: DFZ05
- Blank**
Cat #: DF-Diam-B
Ex.: DF05-B
- Days**
Cat #: DFL-Diam
Ex.: DFL05
- Years**
Cat #: DFY-Diam-Starting Year*
Ex.: DFY05-24

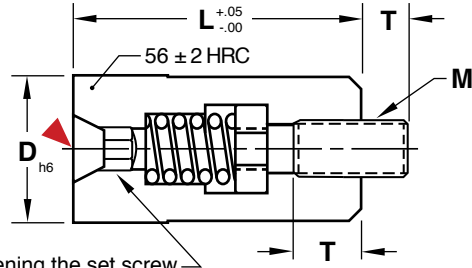
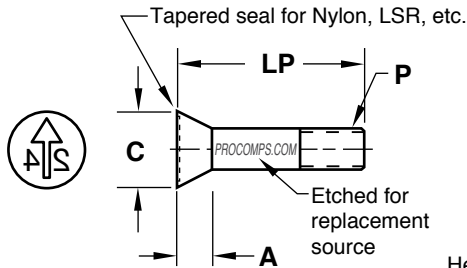


Ring Styles: Raised Lettering

- 0 - 9**
Cat #: DFRN-Diam
Ex.: DFRN05
- A-M**
Cat #: DFRA-Diam
Ex.: DFRA05
- N-Z**
Cat #: DFRZ-Diam
Ex.: DFRZ05
- Days**
Cat #: DFRL-Diam
Ex.: DFRL05
- Months**
Cat #: DFR-Diam
Ex.: DFR05
- Years**
Cat #: DFRY-Diam-Starting Year*
Ex.: DFRY05-24



DATE STAMPS TAPERED SERIES



Hex is present for tightening the set screw thread from parting line when plug is not installed.

PLUGS



M 420 Stainless (1.4034) **H** 54-58 HRC

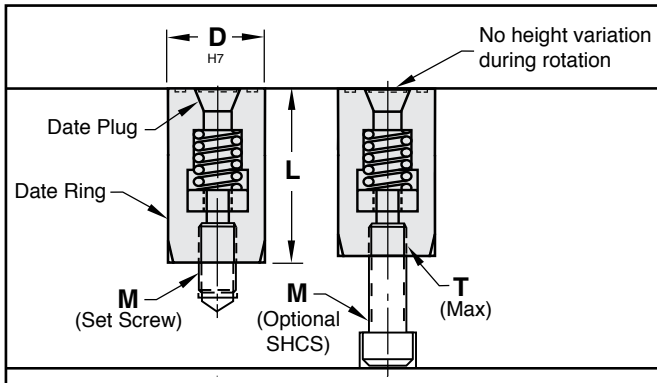
RINGS



▶ CAD insertion point

CATALOG NUMBER	C	A	LP	P	ENGRAVING DEPTH (ARROW)
DTPRP04-24	2.5	2.3	10.5	M1.4 x 0.2	.30
DTPRP05-24	3.1	2.8	13.0	M1.6 x 0.2	.40
DTPRP06-24	3.1	2.8	13.0	M1.6 x 0.2	.40
DTPRP08-24	4.6	4.0	14.0	M2.5 x 0.35	.60
DTPRP10-24	4.6	4.0	14.0	M2.5 x 0.35	.60
DTPRP12-24	6.4	4.0	17.0	M3 x 0.5	.60
DTPRP16-24	8.4	5.0	23.0	M3.5 x 0.6	.60
DTPRP20-24	11	6.5	23.0	M3.5 x 0.6	.60

CATALOG NUMBER	D	L	M	T	ENGRAVING DEPTH
DTPR04	4	14	M2 x 0.4	3	.15
DTPR05	5	17	M3 x 0.5	3	.20
DTPR06	6	17	M3 x 0.5	3	.20
DTPR08	8	20	M4 x 0.7	4	.30
DTPR10	10	20	M5 x 0.8	4	.30
DTPR12	12	25	M6 x 1.0	6	.30
DTPR16	16	33	M8 x 1.25	8	.30
DTPR20	20	33	M8 x 1.25	8	.30



To Order:

- Specify catalog number as shown above and below for the different style plugs and rings.
- Where years are specified (*), any year can be ordered by changing the suffix. Example: DTPRP05-25 or DTPRY05-26.
- To create Date Stamps for days, purchase both the 0-30 ring (DTPRT) and the 0-9 ring (DTPRN) and the desired plugs.
- Special configurations are available. Contact Customer Service for more information.

Plug Styles: Recessed Lettering



Arrow Only

Cat #: DTPRP-Diam-AO
Ex.: DTPRP05-AO



C

Cat #: DTPRP-Diam-C
Ex.: DTPRP05-C

Ring Styles: Recessed Lettering



0 - 9

Cat #: DTPRN-Diam
Ex.: DTPRN05



A - M

Cat #: DTPRA-Diam
Ex.: DTPRA05



0 - 30

Cat #: DTPRT-Diam
Ex.: DTPRT05



N - Z

Cat #: DTPRZ-Diam
Ex.: DTPRZ05



Blank

Cat #: DTPR-Diam-B
Ex.: DTPR05-B



Years

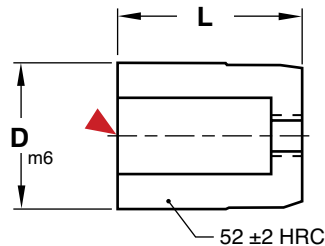
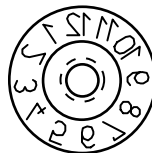
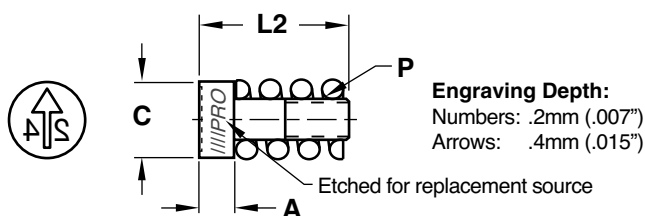
Cat #: DTPRY-Diam-Starting Year*
Ex.: DTPRY05-24

APPLICATION GUIDELINES

- Ring can be installed using the included set screw or retained with a screw from the back.
- Maximum mold temperature:
Ø4mm: 662°F (350°C)
Ø5-Ø20mm: 932°F (500°C)

DATE STAMPS

CH SERIES: COMPACT HEIGHT



PLUGS



RINGS



M 420 Stainless (1.4034) **H** 54-58 HRC

CAD insertion point

CATALOG NUMBER	C	A	L2	P
DCP04-24	2.2	2.0	8	M1x0.25
DCP05-24	3.1	2.0	8	M1.6x0.20
DCP06-24	3.1	2.0	8	M1.6x0.20
DCP08-24	4.4	2.5	10	M2.3x0.25
DCP10-24	5.2	3.0	12	M2.5x0.35
DCP12-24	6.2	3.0	14	M3x0.35
DCP16-24	8.2	3.5	14	M4x0.35
DCP20-24	11.0	4.5	16	M4x0.35

CATALOG NUMBER	D	L	B FROM GRAPHIC BELOW
DC04	4	8	1.4
DC05	5	8	2
DC06	6	8	2
DC08	8	10	3
DC10	10	12	3
DC12	12	14	4
DC16	16	14	5
DC20	20	16	5

To Order:

- Specify catalog number as shown above and below for the different style plugs and rings.
- Where years are specified (*), any year can be ordered by changing the suffix. Example: DCP05-25 or DCY05-26.
- Use both the Weeks Ring (DCW) and 0-9 Ring (DCN) to designate specific weeks of the year.
- Plugs include springs and replacements are available.
- Special configurations are available. Contact Customer Service for more information.

APPLICATION GUIDELINES

- Maximum mold temperature: 285°F (140°C)

Plug Styles: Recessed Lettering

Arrow Only



Cat #: DCP-Diam-AO
Ex.: DCP05-AO

C



Cat #: DCP-Diam-C
Ex.: DCP05-C

Ring Styles: Recessed Lettering

0 - 9



Cat #: DCN-Diam
Ex.: DCN05

A - M



Cat #: DCA-Diam
Ex.: DCA05

Blank



Cat #: DC-Diam-B
Ex.: DC05-B

N - Z



Cat #: DCZ-Diam
Ex.: DCZ05

Days



Cat #: DCL-Diam
Ex.: DCL05

Years



Cat #: DCY-Diam-Starting Year*
Ex.: DCY05-24

Note: The DCL04 and DCL05 does not have tick marks.

Quarters



Cat #: DCQ-Diam
Ex.: DCQ05

Shifts

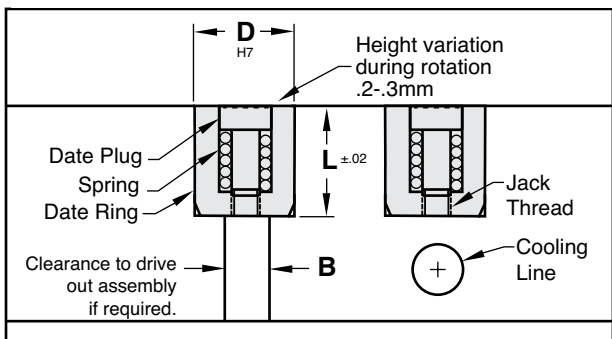


Cat #: DCS-Diam
Ex.: DCS05

Weeks

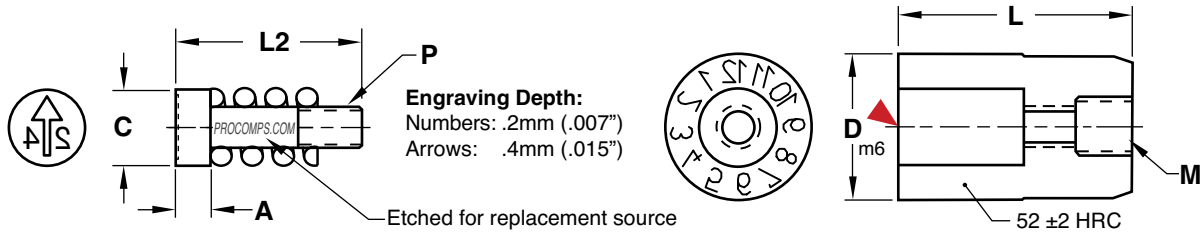


Cat #: DCW-Diam
Ex.: DCW05





DATE STAMPS 20 SERIES: 20MM LENGTH



PLUGS



M 420 Stainless (1.4034) **H** 50-54 HRC

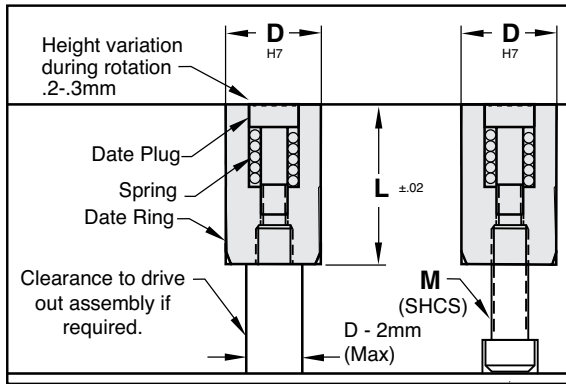
CATALOG NUMBER	C	A	L2	P	ARROW ONLY
DLP06-24	3.1	3.0	13	M1.6x0.20	DLP06-AO
DLP08-24	4.6	4.0	14	M2.5x0.35	DLP08-AO
DLP10-24	4.6	4.0	14	M2.5x0.35	DLP10-AO
DLP16-24	8.2	3.5	14	M4x0.35	DLP16-AO

RINGS



▶ CAD insertion point

CATALOG NUMBER	D	M	L
DL06	6	M3x0.5	20
DL08	8	M4x0.7	
DL10	10	M5x0.8	
DL16	16	M8x1.25	



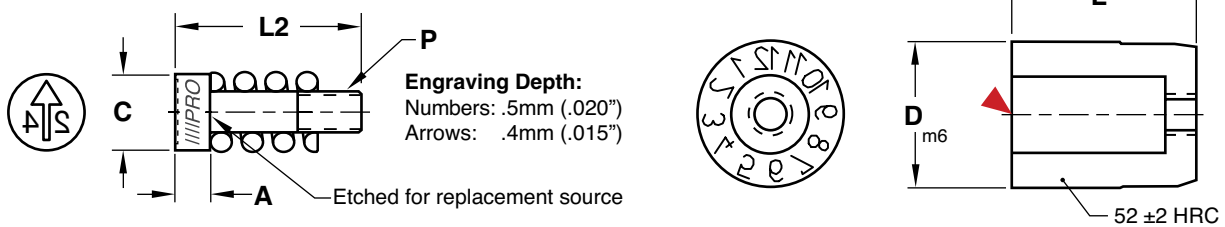
APPLICATION GUIDELINES

- Maximum mold temperature: 285°F (140°C)

To Order:

- For other date plugs, modify catalog number for the year required. Example: DLP06-25.
- Plugs include springs and replacements are available.
- Special configurations are available. Contact Customer Service for more information.

D SERIES: DEEP ENGRAVING



RINGS

PLUGS

M 420 Stainless (1.4034) **H** 50-54 HRC

CATALOG NUMBER	C	A	L2	P	ARROW ONLY
DCP10D-24	5.2	3.0	12	M2.5x0.35	DCP10-AO
DCP12D-24	6.2	3.0	14	M3x0.35	DCP12-AO
DCP16D-24	8.2	3.5	14	M4x0.35	DCP16-AO
DCP20D-24	11.0	4.5	16	M4x0.35	DCP20-AO

▶ CAD insertion point

CATALOG NUMBER	D	L
DC10-D	10	12
DC12-D	12	14
DC16-D	16	14
DC20-D	20	16

To Order:

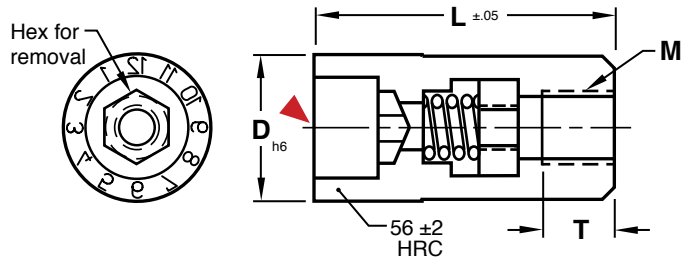
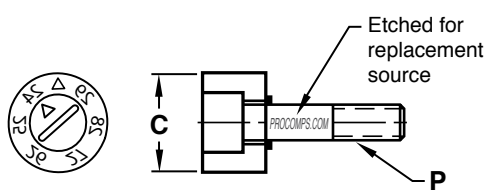
- For other date plugs, modify catalog number for the year required. Example: DCP16D-25.
- Plugs include springs and replacements are available.
- Special configurations are available. Contact Customer Service for more information.

APPLICATION GUIDELINES

- Maximum mold temperature: 285°F (140°C)

DATE STAMPS

MULTI-DATERS



PLUGS



M 420 Stainless (1.4034) **H** 54-58 HRC

CATALOG NUMBER	C	SLOT DEPTH	P	ENGRAVING DEPTH (ARROW)
DMDP06-24	4.2	0.4	M1.6x0.2	0.10
DMDP08-24	5.8	0.4	M2.5x0.35	0.10
DMDP10-24	7.0	0.4	M2.5x0.35	0.10
DMDP12-24	8.5	0.6	M3.0x0.5	0.20
DMDP16-24	11.5	0.6	M3.0x0.6	0.25

RINGS



▶ CAD insertion point

CATALOG NUMBER	D	L	M	T	ENGRAVING DEPTH
DMD06	6	17	M3 x 0.5	3	0.10
DMD08	8	20	M4 x 0.7	4	0.12
DMD10	10	20	M5 x 0.8	4	0.13
DMD12	12	25	M6 x 1.0	6	0.20
DMD16	16	33	M8 x 1.25	8	0.25



Years & Months plug style is featured in the table above.



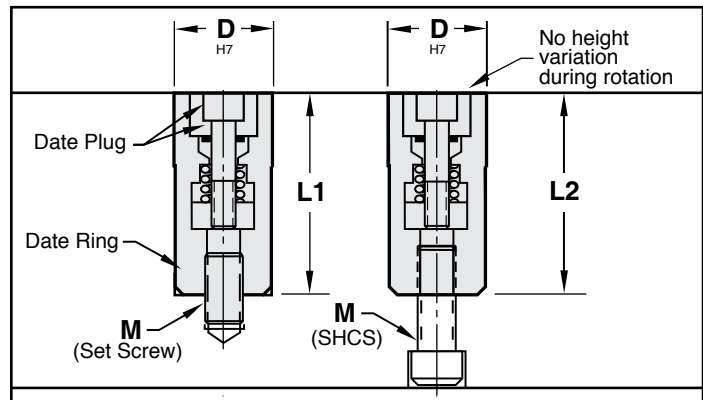
Months ring style is featured in the table above.

To Order:

- Specify catalog number as shown above or below for the different style plugs or rings.
- Where years are specified (*), any year can be ordered by changing the suffix. Example: DMDP10-25 or DMDP06-26.
- Special configurations are available. Contact Customer Service for more information.

APPLICATION GUIDELINES

- Maximum mold temperature: 450°F (230°C)



Plug Styles: Recessed Lettering



Arrow & 6 Years

Cat #: DMDP-Diam-Starting Year*-5
Ex.: DMDP06-245



Arrow & 11 Years

Cat #: DMDP-Diam-Starting Year*-11
Ex.: DMDP06-2411

Ring Styles: Recessed Lettering



Days

Cat #: DMDL-Diam
Ex.: DMDL06



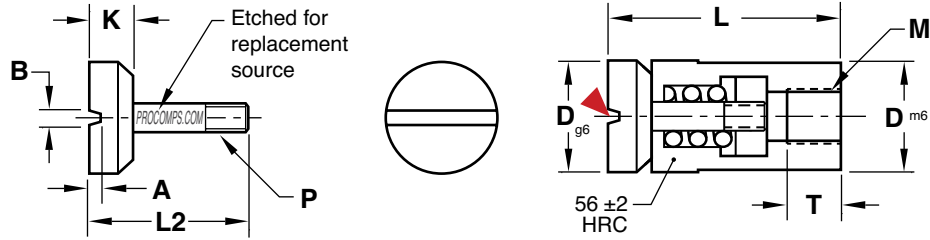
Weeks

Cat #: DMDW-Diam
Ex.: DMDW06



DATE STAMPS

FD SERIES: FULL DIAMETER PLUG



PLUGS

SHELL



M 420 Stainless (1.4034) **H** 54-58 HRC

CATALOG NUMBER	A	B	K	L2	P
DFDPY03-24	.3	.3	2.0	9.0	M1x0.25
DFDPY04-24	.3	.3	2.3	10.5	M1.4x0.2

CATALOG NUMBER	D	T	L	M
DFD03-S	3	3	14	M2 x 0.4
DFD04-S	4	3	14	M2 x 0.4

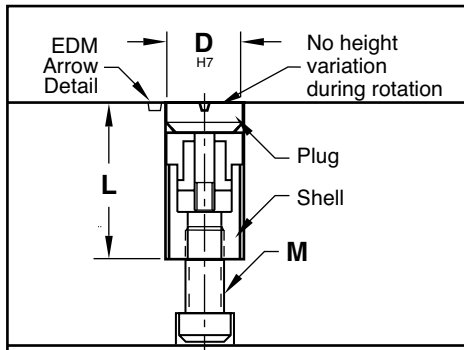
▶ CAD insertion point



Month & Year*
 Cat #: DFDPY-Diam-Starting Year*
 Ex.: DFDPY03-24



Months
 Cat #: DFDP-Diam
 Ex.: DFDP03



APPLICATION GUIDELINES

- Maximum mold temperature: 285°F (140°C)

To Order:

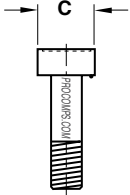
- Specify catalog number as shown above for the different style plugs or shells.
- Where years are specified (*), any year can be ordered by changing the suffix. Example: DFDPY03-25 or DFDPY03-26.
- Special configurations are available. Contact Customer Service for more information.

DATE STAMPS REPLACEMENT PLUGS

Refer to the catalog pages for the specific series required for plugs with alternate engraving such as "C", "Arrow Only", or raised versions. Contact Customer Service for availability of special plugs or for verification of the plugs required in your application.

LOCKING SERIES

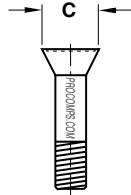
To replace Progressive's Locking Series plugs



CATALOG NUMBER	DATE RING CATALOG NUMBER	C
DNP03-24	DN03	1.6
DNP04-24	DN04	2.5
DNP05-24	DN05	3.1
DNP06-24	DN06	3.1
DNP08-24	DN08	4.6
DNP10-24	DN10	4.6
DNP12-24	DN12	6.4
DNP16-24	DN16	8.4

TAPERED SERIES

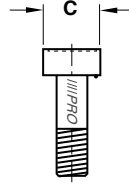
To replace Progressive's Tapered Series plugs



CATALOG NUMBER	DATE RING CATALOG NUMBER	C
DTPRP04-24	DTPR04	2.5
DTPRP05-24	DTPR05	3.1
DTPRP06-24	DTPR06	3.1
DTPRP08-24	DTPR08	4.6
DTPRP10-24	DTPR10	4.6
DTPRP12-24	DTPR12	6.4
DTPRP16-24	DTPR16	8.4
DTPRP20-24	DTPR20	11.0

COMPACT LOCKING

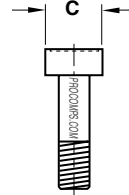
To replace Progressive's Compact Locking Series plugs



CATALOG NUMBER	DATE RING CATALOG NUMBER	C
DTNP03-24	DTN03	1.6
DTNP04-24	DTN04	2.5
DTNP05-24	DTN05	3.1
DTNP06-24	DTN06	3.1
DTNP08-24	DTN08	4.4
DTNP10-24	DTN10	5.2
DTNP12-24	DTN12	6.2
DTNP16-24	DTN16	8.2
DTNP20-24	DTN20	11.0

RF SERIES

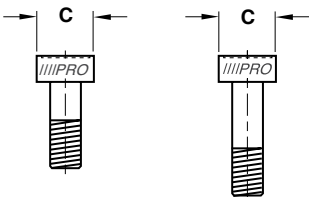
To replace Progressive's RF or H Series plugs.



CATALOG NUMBER	DATE RING CATALOG NUMBER	C
DFP03-24	DF03	1.6
DFP04-24	DF04	2.5
DFP05-24	DF05	3.1
DFP06-24	DF06	3.1
DFP08-24	DF08	4.6
DFP10-24	DF10	4.6
DFP12-24	DF12	6.4
DFP16-24	DF16	8.4

CH, D, & 20 SERIES

To replace Progressive's CH, D, or 20 Series plugs or DME front style plugs. Springs included.

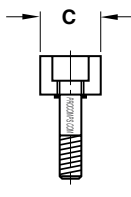


CATALOG NUMBER	DATE RING CATALOG NUMBER	C
DCP04-24	DC04	2.2
DCP05-24	DC05	3.1
DCP06-24	DC06	3.1
DCP08-24	DC08	4.4
DCP10-24	DC10	5.2
DCP12-24	DC12	6.2
DCP16-24	DC16	8.2
DCP20-24	DC20	11.0
DLP06-24	DL06	3.1
DLP08-24	DL08	4.6
DLP10-24	DL10	4.6
DLP16-24	DL16	8.2

For D Series replacements, add "D" to the CH Series catalog number. Ex. DCP16D-24.

MULTI-DATERS

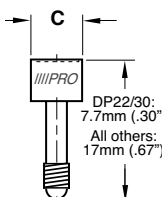
To replace Progressive's Multi-Dater Plugs.



CATALOG NUMBER	DATE RING CATALOG NUMBER	C
DMDP06-24	DMD06	4.2
DMDP08-24	DMD08	5.8
DMDP10-24	DMD10	7.0
DMDP12-24	DMD12	8.5
DMDP16-24	DMD16	11.5

RETRO PLUGS

To replace plugs previously purchased for PCS®/Cumasa® style rings.

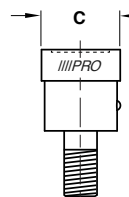


CATALOG NUMBER	DATE RING CATALOG NUMBER	C
DP22-24	DS04	2.2
DP30-24	DS05	3.0
DP32-24	DS06	3.2
DP47-24	DS08	4.7
DP57-24	DS10	5.7
DP67-24	DS12	6.7
DP87-24	DS16	8.7

For Retro Plugs outside of North America, call for availability from local distributors.

INDEXABLE PLUGS

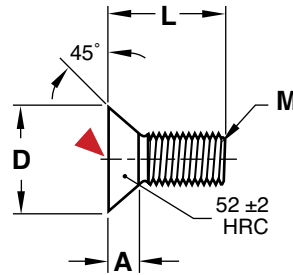
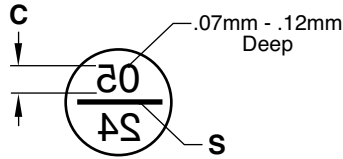
To replace plugs previously purchased for DME® Indexable style rings.



CATALOG NUMBER	DATE RING DME NUMBER	C
DXP04-24	UUM0004	2.4
DXP06-24	UUM0006	3.7
DXP08-24	UUM0008	5.0
DXP10-24	UUM0010	6.3
DXP12-24	UUM0012	7.5
DXP16-24	UUM0016	11.0
DXP20-24	UUM0020	13.2



DATE STAMPS MICRODATERS®



M 420 Stainless (1.4034)

H 50-54 HRC

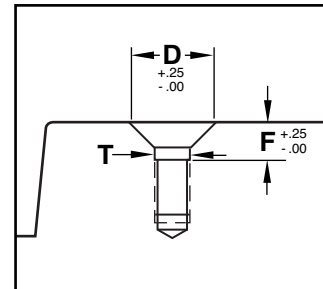
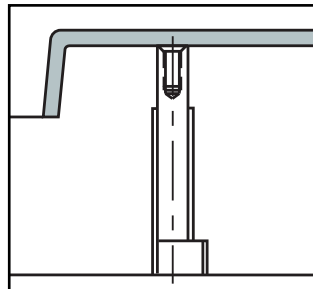
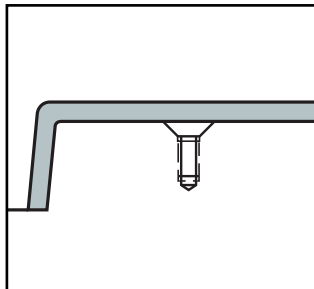
▶ CAD insertion point

CATALOG NUMBER	D	L	A	M	C	F	T	S WIDTH X DEPTH	BLANK CAT. NO.
MD02	2	5	.45	M1.4x0.3	.50	1.14	1.4	.38 x .25	MD02-B
MD03	3	5	.76	M1.8x0.35	.75	1.52	1.8	.38 x .38	MD03-B
MD04	4	6	.89	M2.5x0.45	1.0	1.65	2.7	.38 x .38	MD04-B

Blank (-B) MicroDaters do not have numbers or the removal slot, ready for custom engraving by the mold maker.

APPLICATION GUIDELINES

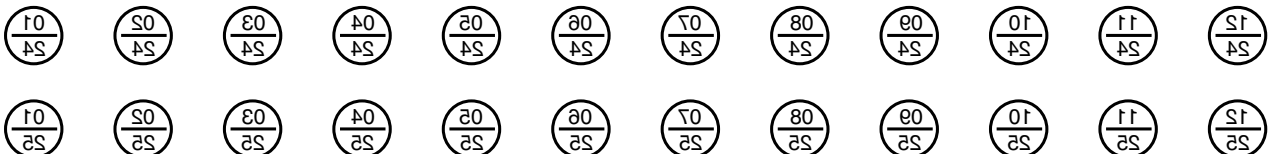
- Microdaters can be installed directly into the plates (left graphic) or inserts or into a core pin or ejector pin (middle graphic) with the material hardness around 35-40 HRC to utilize conventional machining methods.
- Drill, tap and counterbore the dater as shown in the graphic below right and to the dimensions in the chart above.



To Order:

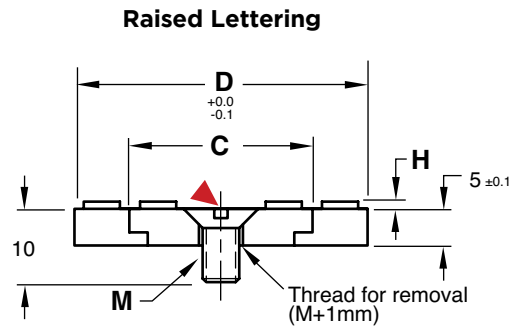
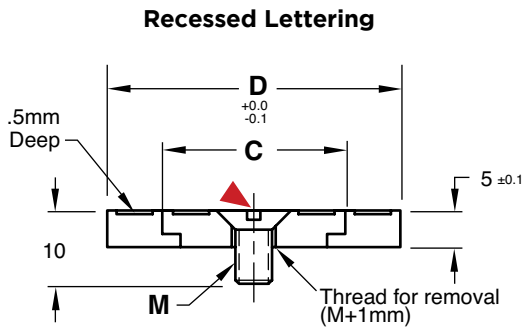
MicroDaters can be ordered individually or in full year (12 month) sets, Jan-Dec.

- For individual month daters, specify the 2-digit month and year at the end of the catalog number: Ex. MD04-03-24 for a 4mm screw for March 2024.
- To order a 12-month set, specify a "Y" at the end of the catalog number, followed by the year. Ex. MD03-Y-24 would yield (12) 3mm screws starting in January 2024 and ending December 2024. For 2025 full year sets (Jan-Dec), specify MD03-Y-25 for the 3mm size, for example. Both year sets are shown below in 2:1 scale.



DATE STAMPS

LG SERIES: LARGE MOLD, STRUCTURAL FOAM/BLOW MOLDS



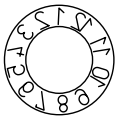
Brass: **M** Ms 58

Steel: **M** O-1 (1.2510) **H** 52-56 HRC

▶ CAD insertion point

D	C	M	H RAISED HEIGHT
15	10	M3 x 0.5	0.5
20	13	M3 x 0.5	1.0
30	19	M4 x 0.7	1.0
40	25	M5 x 0.8	1.0

Ring Styles: Recessed Lettering



Months

Cat #: DLB-Diam (Brass)
DLS-Diam (Steel)
Ex.: DLB40, DLS40



Days

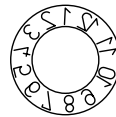
Cat #: DLBL-Diam (Brass)
DLSL-Diam (Steel)
Ex.: DLBL40, DLSL40



Years

Cat #: DLBY-Diam - Starting Year* (Brass)
DLSY-Diam - Starting Year* (Steel)
Ex.: DLBY40-24, DLSY40-24

Ring Styles: Raised Lettering



Months

Cat #: DLBR-Diam (Brass)
DLSR-Diam (Steel)
Ex.: DLBR40, DLSR40



Days

Cat #: DLBRL-Diam (Brass)
DLSRL-Diam (Steel)
Ex.: DLBRL40, DLSRL40



Years

Cat #: DLBRY-Diam - Starting Year* (Brass)
DLSRY-Diam - Starting Year* (Steel)
Ex.: DLBRY40-24, DLSRY40-24

Plug Styles: Recessed Lettering



Arrow Only

Cat #: DLBP-Diam - AO (Brass)
DLSP-Diam - AO (Steel)
Ex.: DLBP40-AO, DLSP40-AO



Years

Cat #: DLBP-Diam - Year* (Brass)
DLSP-Diam - Year* (Steel)
Ex.: DLBP40-24, DLSP40-24



Arrow Only

Cat #: DLBRP-Diam - AO (Brass)
DLSRP-Diam - AO (Steel)
Ex.: DLBRP40-AO, DLSRP40-AO



Years

Cat #: DLBRP-Diam - Year* (Brass)
DLSRP-Diam - Year* (Steel)
Ex.: DLBRP40-24, DLSRP40-24

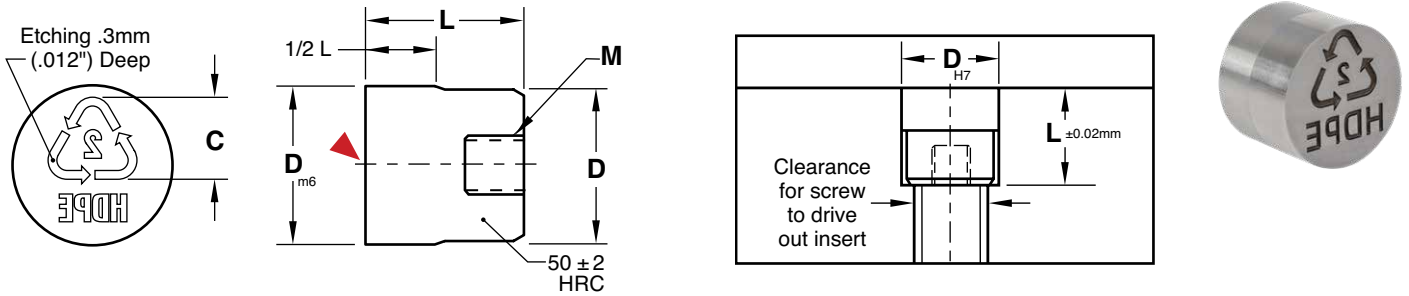
To Order:

- Specify catalog number as shown above for the different style plugs or rings.
- Where years are specified (*), any year can be ordered by changing the suffix. Example: DLBP15-25 or DLSP15-26.
- Special configurations are available. Contact Customer Service for more information.



RECYCLE INSERTS

SPI & ASTM STANDARDS



SPI STANDARD	0	1	2	3	4	5	6	7

ASTM STANDARD	0	1	2	3	4	5	6	7

M 420 Stainless (1.4034) **H** 48-52 HRC

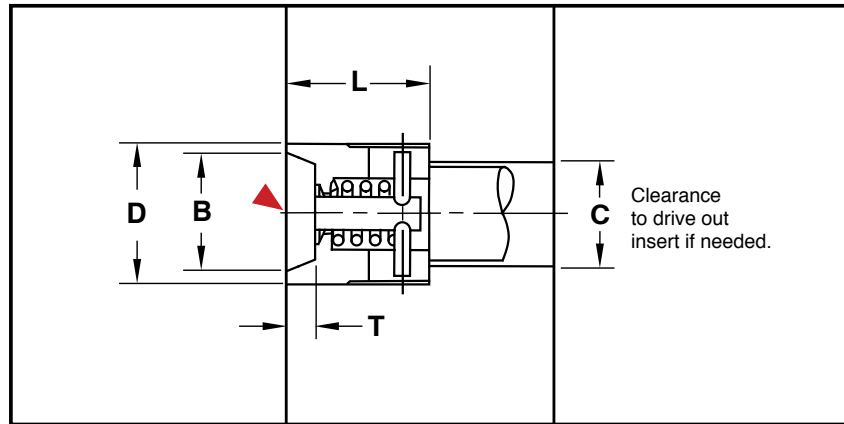
CAD insertion point

SPI CATALOG NUMBER	ASTM CATALOG NUMBER	D	MATERIAL CODE	MATERIAL	L	C	M
RI-10-0	RIS-10-0	10mm (.3937")	N/A	BLANK	12 mm (.4724")	6 mm (.2362")	M5 x .08
RI-10-1	RIS-10-1		1	POLYETHYLENE TEREPHTHALATE			
RI-10-2	RIS-10-2		2	HIGH DENSITY POLYETHYLENE			
RI-10-3	RIS-10-3		3	POLYVINYL CHLORIDE			
RI-10-4	RIS-10-4		4	LOW DENSITY POLYETHYLENE			
RI-10-5	RIS-10-5		5	POLYPROPYLENE			
RI-10-6	RIS-10-6		6	POLYSTYRENE			
RI-10-7	RIS-10-7		7	OTHER			
RI-16-0	RIS-16-0	16mm (.6299")	N/A	BLANK	14 mm (.5518")	10 mm (.3937")	M6 x 1.0
RI-16-1	RIS-16-1		1	POLYETHYLENE TEREPHTHALATE			
RI-16-2	RIS-16-2		2	HIGH DENSITY POLYETHYLENE			
RI-16-3	RIS-16-3		3	POLYVINYL CHLORIDE			
RI-16-4	RIS-16-4		4	LOW DENSITY POLYETHYLENE			
RI-16-5	RIS-16-5		5	POLYPROPYLENE			
RI-16-6	RIS-16-6		6	POLYSTYRENE			
RI-16-7	RIS-16-7		7	OTHER			
RI-20-0	RIS-20-0	20mm (.7874")	N/A	BLANK	16 mm (.6299")	12 mm (.4724")	M6 x 1.0
RI-20-1	RIS-20-1		1	POLYETHYLENE TEREPHTHALATE			
RI-20-2	RIS-20-2		2	HIGH DENSITY POLYETHYLENE			
RI-20-3	RIS-20-3		3	POLYVINYL CHLORIDE			
RI-20-4	RIS-20-4		4	LOW DENSITY POLYETHYLENE			
RI-20-5	RIS-20-5		5	POLYPROPYLENE			
RI-20-6	RIS-20-6		6	POLYSTYRENE			
RI-20-7	RIS-20-7		7	OTHER			

APPLICATION GUIDELINES

- To avoid damage to face, press insert into hole using a brass or plastic mallet.
- Contact Customer Service for pricing and availability of other sizes or material engraving.

AIR POPPETS



▶ CAD insertion point

APPLICATION GUIDELINES

- Operating Pressure: 80 psi min. / 100 psi max.
- Maximum Mold Temperature: 285°F (140°C)
- Avoid machining on the front face.
- The activation of the Air Poppet should occur at, or slightly before, part ejection.
- The air pressure must end prior to injection, allowing the spring to retract the piston. Failure to do so may allow molten material to enter into the valve, causing damage to the poppet or cavity.

Inch Standard

M 420 Stainless (1.4034) **H** 40-44 HRC

CATALOG NUMBER	D ± .0002	B	C	T	L +.000 -.002	REPAIR KIT CATALOG NUMBER
APV-25	.250	.215	3/16	.06	.375	APVR-25
APV-37	.375	.325	9/32	.07	.375	APVR-37
APV-50	.500	.437	3/8	.10	.500	APVR-50
APV-75	.750	.656	9/16	.15	.750	APVR-75
APV-100	1.000	.875	3/4	.20	1.000	APVR-100
APV-150	1.500	1.312	1	.30	1.500	APVR-150

The Repair Kit includes a spring and pin.

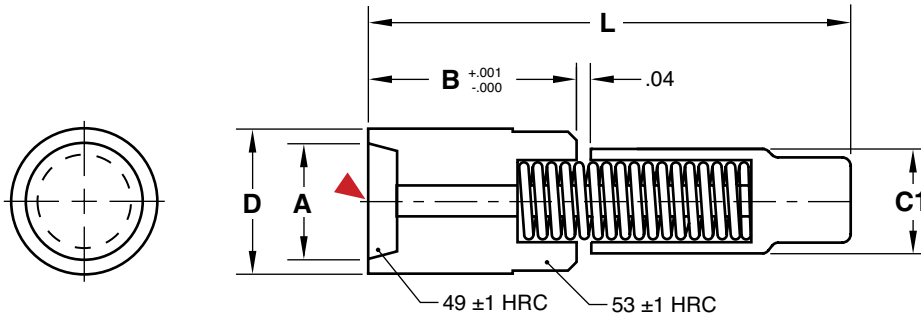
Metric Standard

M 420 Stainless (1.4034) **H** 52-54 HRC

CATALOG NUMBER	D +.003 -.005	B	C	T	L +.00 -.03	REPLACEMENT SPRING CATALOG NUMBER
APV-06	6	5	4	1	12	APVR-06
APV-08	8	6.5	5			APVR-08
APV-10	10	8	7			APVR-10
APV-12	12	10	8			APVR-12
APV-16	16	13	12			20



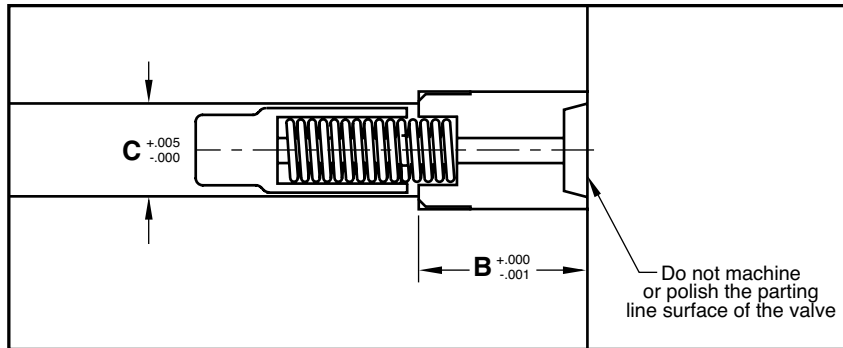
AIR VALVES



M 420 Stainless (1.4034) **H** Body: 52-54 HRC, Plunger: 48-50 HRC (DLC Coated)

CATALOG NUMBER	D		A		B		C1		L	
	MM	Inch	MM	Inch	MM	Inch	MM	Inch	MM	Inch
AV-08	8	.3149 +.0006 +.0002	6.5	.256	11	.433	6	.24	24	1.0
AV-12	12	.4724 +.0007 +.0003	9.7	.382	18	.708	8	.32	34	1.4
AV-18	18	.7086 +.0007 +.0003	14.8	.583	22	.866	12	.47	46	1.8

▶ CAD insertion point



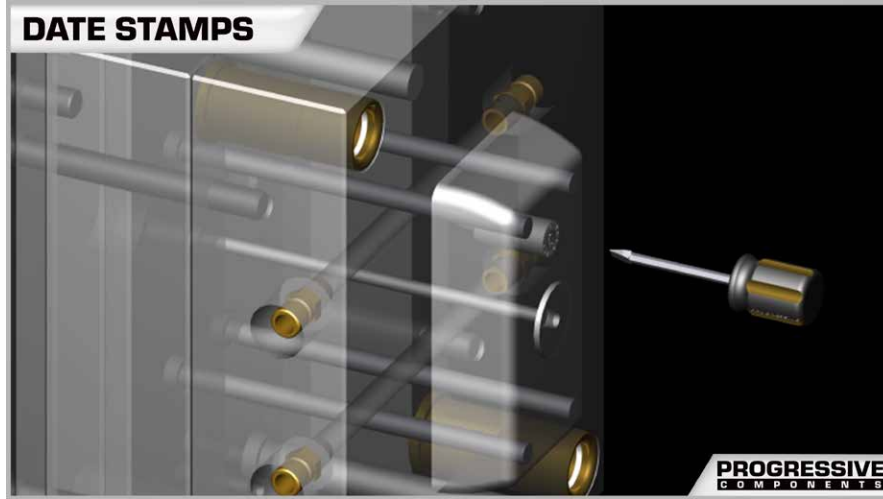
Suggested Machining Diameters

CATALOG NUMBER	C
AV-08	.265
AV-12	.354
AV-18	.551

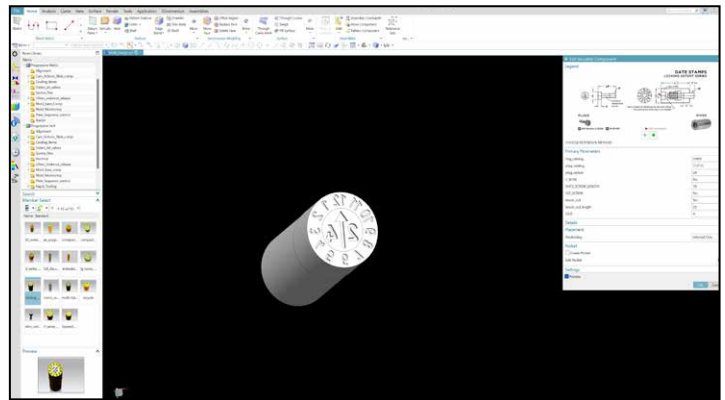
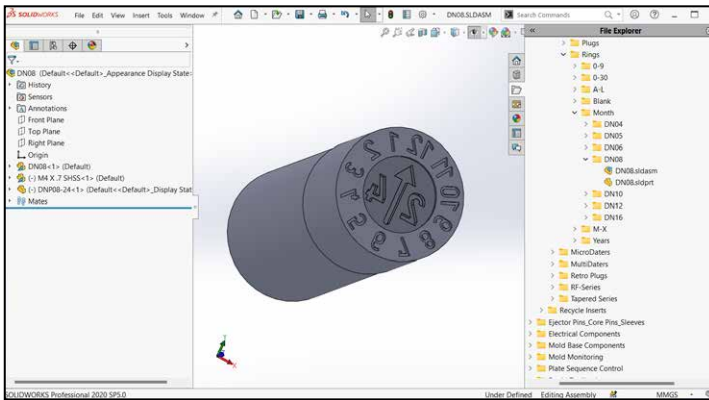
APPLICATION GUIDELINES

- Assemblies feature corrosion-resistant stainless steel spring.
- Operating Pressure: 29 psi min. / 140 psi max.
- Maximum Mold Temperature: 265°F (130°C)
- Press-fit installation required.
- Avoid machining on the front face.
- The activation of the Air Valve should occur at, or slightly before, part ejection.
- The air pressure must end prior to injection, allowing the spring to retract the piston. Failure to do so may allow molten material to enter into the valve, causing damage to the valve or cavity.

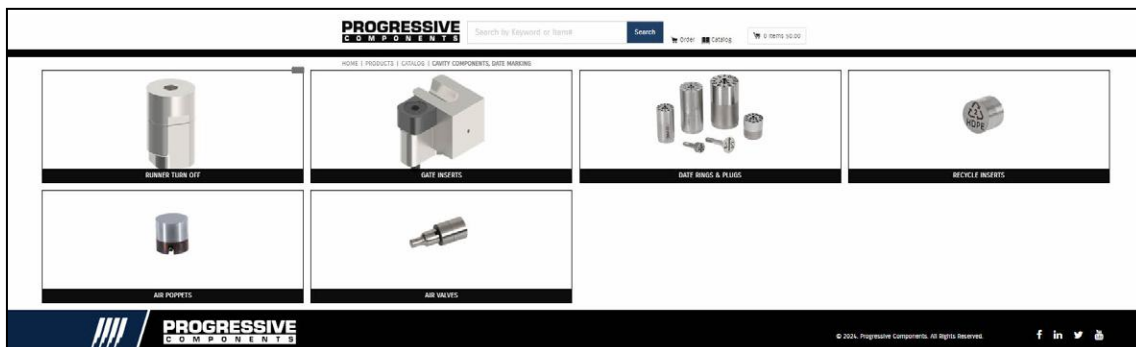
ONLINE RESOURCES



When considering design options, numerous animations can be viewed at procomps.com/animations.



CAD geometry is available online as individual downloads or as part of the CADalog system. The seven formats include: IGES (.igs), ACIS (.sat), STEP (.step), Parasolid (.x_t), SolidWorks (.sldasm), NX (.prt) (Re-Use and MoldWizard) and Visi (.wkf).



Industry-leading web store expedites the purchasing process. Go to shop.procomps.com for information and additional resources.



COOLING PRODUCTS

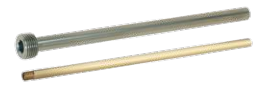
SECTION E



Pipe Check	Baffles	Jumper Baffles	Reverse Flow Baffles	Cascade: Nipple Type
Prefix: PC	Prefix: SB, TB	Prefix: JBA	Prefix: RFB	Prefix: NC
Page: E-1	Page: E-2	Page: E-4	Page: E-5	Page: E-6



Cascade: High Flow	Cascade: Rear Load	Cascade: RL Quick Cplr.	Cascade: Hex Key	Cascade: Quick Coupler
Prefix: HFC	Prefix: RLN	Prefix: RLQC	Prefix: HKC, CC	Prefix: QC
Page: E-7	Page: E-8	Page: E-9	Page: E-10	Page: E-11



Bubbler Base	Inlet Cascade	Metric Tubes: High Flow	Tubes: High Flow, Hex	Tubes: Piston, Brass
Prefix: BBL	Prefix: CF	Prefix: HFTM, HEXM	Prefix: HFT, HEXT	Prefix: PT, T
Page: E-12	Page: E-13	Page: E-14	Page: E-15	Page: E-16



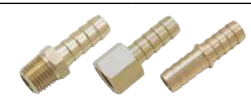
O-Rings	Pipe Plugs	Extension Plugs	Connector Plugs	Socket Connectors
Prefix: OR	Prefix: BR, ST, SS	Prefix: Numeral	Prefix: Numeral	Prefix: SC
Page: E-17	Page: E-20	Page: E-21	Page: E-24	Page: E-25



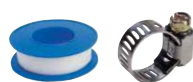
Connector Plugs: Keyed	Socket Conn. Keyed	Safety Clips	Adjustable Hex Nipples	Hex Key Ext. Pipes
Prefix: Numeral, Suffix: -K	Prefix: SC, Suffix: -K	Prefix: SC	Prefix: APN	Prefix: HKEPN
Page: E-26	Page: E-27	Page: E-27	Page: E-28	Page: E-28



Elbows: Hex Key	Pipe Nipples	Push-Lok Hose	Plugs: Water Blockers	Plugs: Threadless
Prefix: HK, HKEE, HKL	Prefix: BPN, GPN	Prefix: WJH	Prefix: WB	Prefix: TWP, TAP, TDP
Page: E-29	Page: E-30	Page: E-30	Page: E-31	Page: E-32



Diverting Rods & Plugs	Water Jumpers	Water Jumpers: Swivel	Elbows: Hex, Extension	Hose Barbs & Splicers
Prefix: DR	Prefix: WJ	Prefix: WJ	Prefix: HELS, HELB	Prefix: MB, FB, HS
Page: E-33	Page: E-34	Page: E-35	Page: E-36	Page: E-37

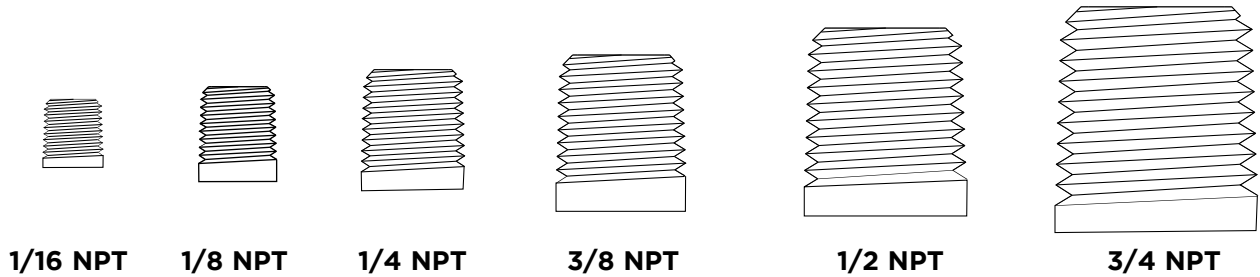


Comb. Hose Inserts	Clamps & Tape	Tees & Elbows	Reducers & Couplings
Prefix: Numeral	Prefix: CP, HC, TT	Prefix: T, MT, ELS, EL	Prefix: RB, MR, C, HN
Page: E-38	Page: E-39	Page: E-40	Page: E-41

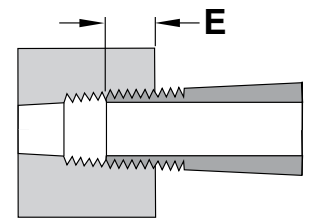


PIPE THREAD DATA

The table below lists standard pipe sizes along with the actual O.D. and I.D. for each size. The nominal size of any pipe does not in fact refer to either the outside diameter (O.D.) or the inside diameter (I.D.) of the pipe. Actual size drawings of pipes from 1/16" to 3/4" are shown below. Note: Nominal Pipe Size, Pipe Size, and Pipe Tap Size all refer to an NPT thread.



PIPE SIZE	THREADS PER INCH	OUTSIDE DIAMETER OF PIPE	INSIDE DIAMETER OF PIPE	TAP DRILL SIZE WITHOUT REAM	TAP DRILL SIZE WITH REAM	E THREAD ENGAGEMENT
1/16	27	.312	.209	1/4	15/64	.250
1/8	27	.405	.269	11/32	21/64	.250
1/4	18	.540	.364	7/16	27/64	.300
3/8	18	.675	.493	9/16	9/16	.300
1/2	14	.840	.622	45/64	11/16	.420
3/4	14	1.050	.824	29/32	57/64	.545
1	11-1/2	1.315	1.049	1-9/64	1-1/8	.661
1-1/4	11-1/2	1.660	1.380	1-31/64	1-15/32	.681
1-1/2	11-1/2	1.900	1.610	1-23/32	1-45/64	.681
2	11-1/2	2.375	2.067	2-3/16	2-11/64	.697



The Thread Engagement column ("E") can be used to determine the length of the component required to properly assemble when fully tightened. The drawing above illustrates this measurement.

PIPE CHECK

M Hard anodized aluminum

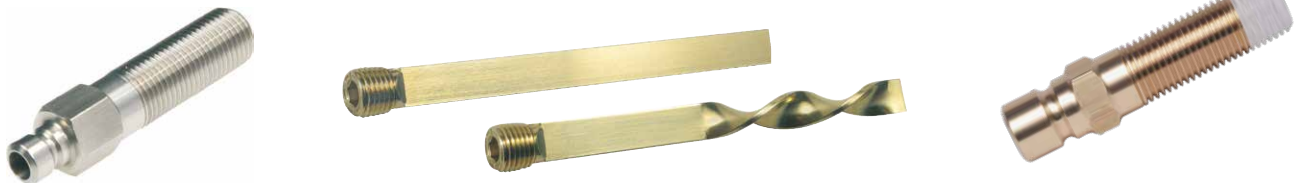
CATALOG NUMBER	DESCRIPTION
PC-100	Pipe Thread Check



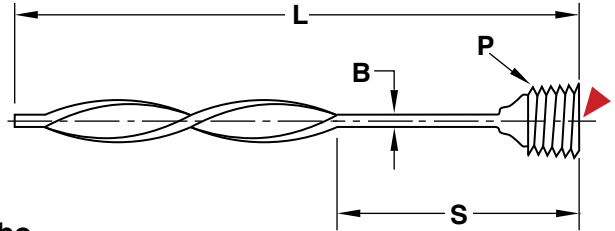
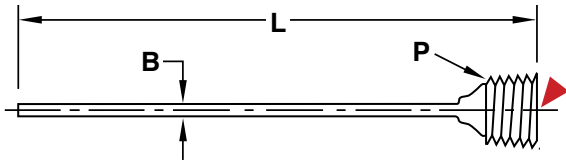
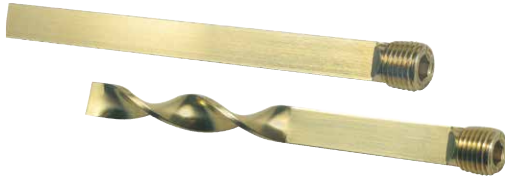
MOLD-READY™ COOLING PRODUCTS

Progressive Components can provide standard items cut to length and ready for installation in the mold. These include Tubes, Extension Plugs, and Adjustable Pipe Nipples and all are available with sealant on the threads. Additional materials are also available on select components. Please refer to the individual pages within this section for more details.

For an application review, contact tech@procomps.com.



BAFFLES
NPT SERIES



Straight

M Brass

CATALOG NUMBER	P PLUG SIZE (NPT)	L	B BLADE THICKNESS	BLADE WIDTH -.005 -.010
SB06L4	1/16-27	4	.057	.250
SB06L8	1/16-27	8	.057	.250
SB06L12	1/16-27	12	.057	.250
SB12L4	1/8-27	4	.057	.312
SB12L8	1/8-27	8	.057	.312
SB12L12	1/8-27	12	.057	.312
SB25L5	1/4-18	5	.085	.437
SB25L10	1/4-18	10	.085	.437
SB25L15	1/4-18	15	.085	.437
SB37L6	3/8-18	6	.093	.562
SB37L12	3/8-18	12	.093	.562
SB37L18	3/8-18	18	.093	.562
SB50L8	1/2-14	8	.093	.687
SB50L16	1/2-14	16	.093	.687
SB75L12	3/4-14	12	.093	.937
SB75L20	3/4-14	20	.093	.937
SB100L16	1-11 1/2	16	.093	1.125
SB100L24	1-11 1/2	24	.093	1.125
SB125L16	1 1/4-11 1/2	16	.093	1.484
SB125L24	1 1/4-11 1/2	24	.093	1.484

Turbo

M Brass

▶ CAD insertion point

CATALOG NUMBER	P PLUG SIZE (NPT)	L	S STRAIGHT LENGTH	B BLADE THICKNESS	BLADE WIDTH -.005 -.010
TB06L4	1/16-27	4	2	.057	.250
TB06L8	1/16-27	8	4	.057	.250
TB06L12	1/16-27	12	6	.057	.250
TB12L4	1/8-27	4	2	.057	.312
TB12L8	1/8-27	8	4	.057	.312
TB12L12	1/8-27	12	6	.057	.312
TB25L5	1/4-18	5	2	.085	.437
TB25L10	1/4-18	10	4	.085	.437
TB25L15	1/4-18	15	6	.085	.437
TB37L6	3/8-18	6	2	.093	.562
TB37L12	3/8-18	12	4	.093	.562
TB37L18	3/8-18	18	6	.093	.562
TB50L8	1/2-14	8	3	.093	.687
TB50L16	1/2-14	16	5	.093	.687
TB75L12	3/4-14	12	4	.093	.937
TB75L20	3/4-14	20	6	.093	.937
TB100L16	1-11 1/2	16	5	.093	1.125
TB100L24	1-11 1/2	24	8	.093	1.125
TB125L16	1 1/4-11 1/2	16	5	.093	1.484
TB125L24	1 1/4-11 1/2	24	8	.093	1.484

BLADE MATERIAL



CATALOG NUMBER	B BLADE THICKNESS	BLADE WIDTH -.005 -.010
BM06	.057	.250
BM12	.057	.312
BM25	.085	.437
BM25-B	.085	.421
BM37	.093	.562
BM50	.093	.687
BM75	.093	.937
BM75-B	.093	.906
BM100	.093	1.125
BM125	.093	1.484

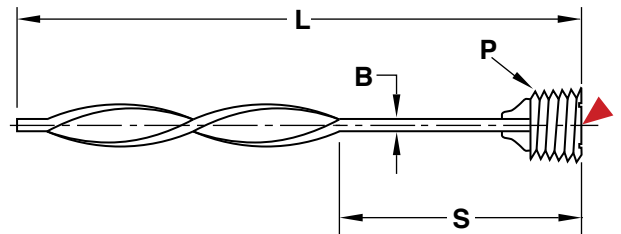
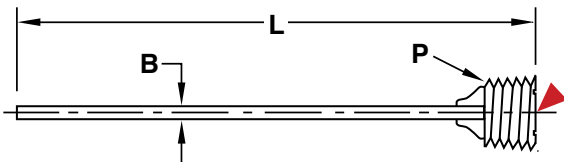
ALTERNATIVE CONFIGURATIONS AVAILABLE

- Straight Baffle Blade Material: Order according to the chart at left. Material is sold in 36" lengths, and other lengths can be provided upon request.
- For Baffles with brass blades and stainless steel pipe plugs, add "-SS" to the end of the catalog number. Ex. SB25L5-SS or TB75L12-SS. Call for pricing on 1-1/4 baffles with stainless steel pipe plugs.
- Baffles can be ordered cut to any length, in any quantity. To order, specify the prefix and plug size and the required length. For Turbo Baffles, the closest straight length (S) is used, but can be provided to a different length, upon request. Ex. SB25L6.25 or TB37L5.75-SS (with a 2" "S" dimension)
- BSPT plug baffles are sold separately on page E-3.



BAFFLES

BSPT SERIES



Straight

M Brass

CATALOG NUMBER	P PLUG SIZE (BSPT)	L	B BLADE THICKNESS	BLADE WIDTH -.005 -.010
SB12L4-BSP	1/8-28	4	.057	.312
SB12L8-BSP	1/8-28	8	.057	.312
SB12L12-BSP	1/8-28	12	.057	.312
SB25L5-BSP	1/4-19	5	.085	.421
SB25L10-BSP	1/4-19	10	.085	.421
SB25L15-BSP	1/4-19	15	.085	.421
SB37L6-BSP	3/8-19	6	.093	.562
SB37L12-BSP	3/8-19	12	.093	.562
SB37L18-BSP	3/8-19	18	.093	.562
SB50L8-BSP	1/2-14	8	.093	.687
SB50L16-BSP	1/2-14	16	.093	.687
SB75L12-BSP	3/4-14	12	.093	.906
SB75L20-BSP	3/4-14	20	.093	.906
SB100L16-BSP	1-11	16	.093	1.125
SB100L24-BSP	1-11	24	.093	1.125

Turbo

M Brass

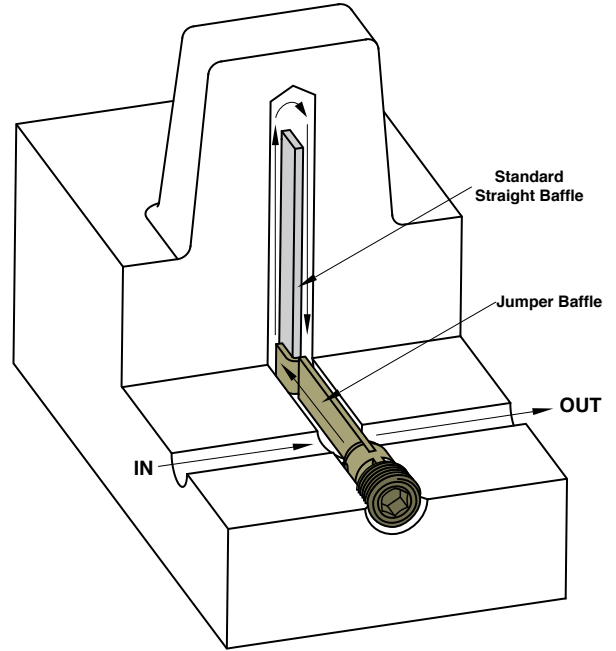
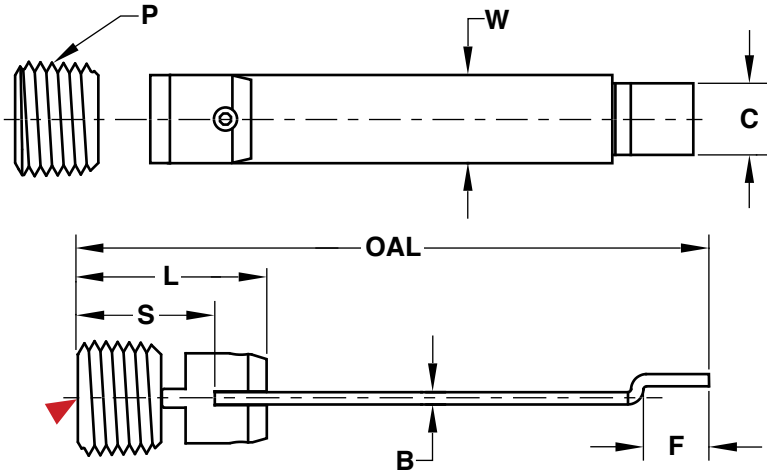
CAD insertion point

CATALOG NUMBER	P PLUG SIZE (BSPT)	L	S STRAIGHT LENGTH	B BLADE THICKNESS	BLADE WIDTH -.005 -.010
TB12L4-BSP	1/8-28	4	2	.057	.312
TB12L8-BSP	1/8-28	8	4	.057	.312
TB12L12-BSP	1/8-28	12	6	.057	.312
TB25L5-BSP	1/4-19	5	2	.085	.421
TB25L10-BSP	1/4-19	10	4	.085	.421
TB25L15-BSP	1/4-19	15	6	.085	.421
TB37L6-BSP	3/8-19	6	2	.093	.562
TB37L12-BSP	3/8-19	12	4	.093	.562
TB37L18-BSP	3/8-19	18	6	.093	.562
TB50L8-BSP	1/2-14	8	3	.093	.687
TB50L16-BSP	1/2-14	16	5	.093	.687
TB75L12-BSP	3/4-14	12	4	.093	.906
TB75L20-BSP	3/4-14	20	6	.093	.906
TB100L16-BSP	1-11	16	5	.093	1.125
TB100L24-BSP	1-11	24	8	.093	1.125

ALTERNATIVE CONFIGURATIONS AVAILABLE

- For Baffles with brass blades and stainless steel pipe plugs, add “-SS” to the end of the catalog number and contact Customer Service for pricing. Ex. SB25L5-BSP-SS or TB75L12-BSP-SS
- Baffles can be ordered cut to any length, in any quantity. To order, specify the prefix and plug size and the required length. For Turbo Baffles, the closest straight length (S) is used, but can be provided to a different length, upon request. Ex. SB25L6.25-BSP or TB37L5.75-BSP-SS (with a 2” “S” dimension)
- Straight Baffle Material is available on page E-2.
- End of Baffle has a ring for identification.

JUMPER BAFFLES



M Brass ▶ CAD insertion point

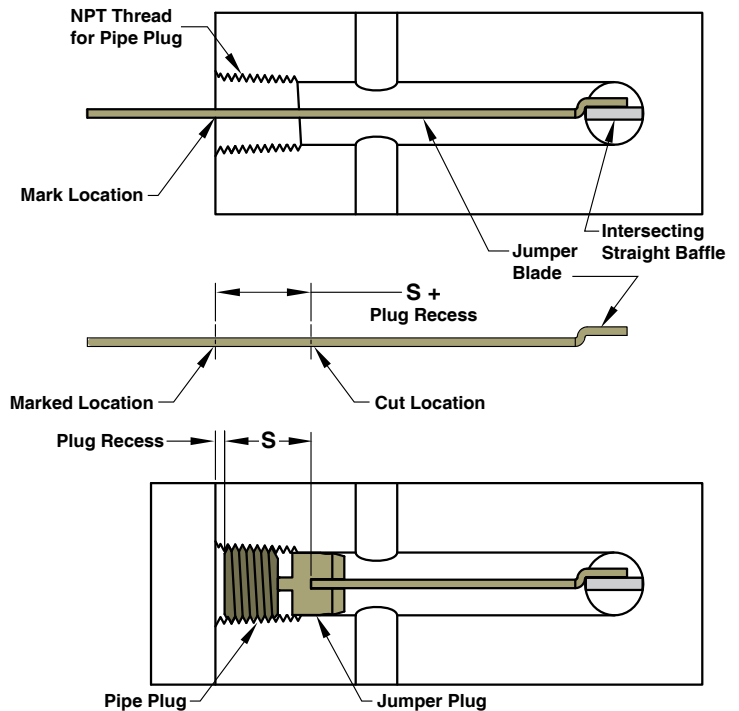
CATALOG NUMBER	P PIPE PLUG SIZE (NPT)	B	W -.005 -.010	L	OAL	S	C	F	SET SCREW SIZE
JBA12	1/8	.06	.312	.66	12.50	.50	.242	.25	#4-40 x 3/32
JBA25	1/4	.06	.437	.90	12.63	.63	.352	.30	#6-32 x 1/8
JBA37	3/8	.06	.562	.90	12.63	.63	.477	.43	#10-32 x 1/8
JBA50	1/2	.06	.687	1.06	12.75	.75	.602	.52	#10-32 x 3/16
JBA75	3/4	.09	.937	1.09	12.75	.75	.852	.70	#10-32 x 3/16

APPLICATION GUIDELINES

- Jumper Baffles enable water routing via interconnected baffles.
- Simplifies design and machining of a complex circuit, reducing the number of feedlines required.
- Replacement Jumper Plug items are available. Assemblies include the Jumper Plug, (2) Set Screws, and a Brass Pipe Plug.
- For application assistance, contact tech@procomps.com.

Installation:

- Install the Jumper Blade so its shoulder rests against the intersection of the Straight Baffle and mark this location.
- Calculate the distance from this marked location by adding the S dimension of the Jumper Plug to the distance that the plug will be recessed into the insert. Cut the Jumper Blade to this length.
- Attach the Jumper Blade to the Jumper Plug using the two set screws.
- Install the assembly into the waterline until it rests against the Straight Baffle. Then, insert the Pipe Plug until it is secured against the Jumper Plug.



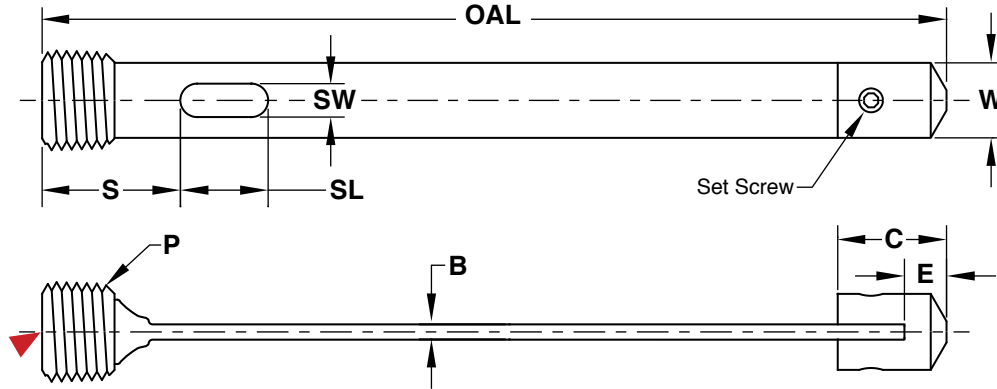


REVERSE FLOW BAFFLES

Reverse Flow Baffles enable the feed line to a baffle to be located opposite the plug end of the baffle to avoid interfering with bushing holes, return pin holes, etc.



- Provides an alternative to circuits with long cross plate gun drilled lines and placement of in-line diverters, simplifying design, machining, and waterline cleaning.



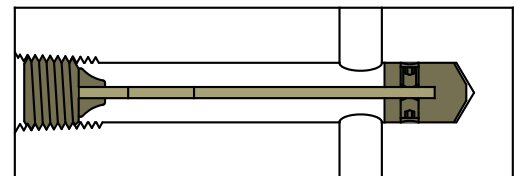
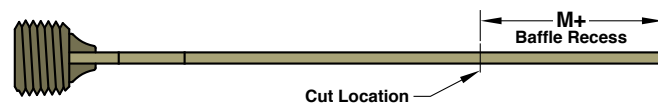
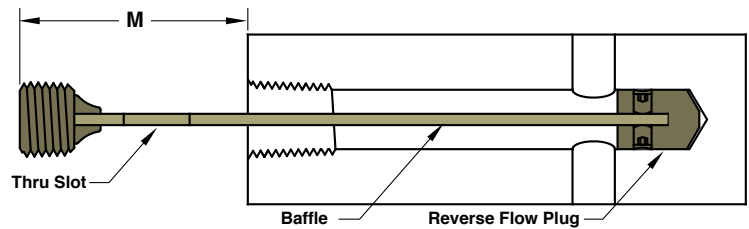
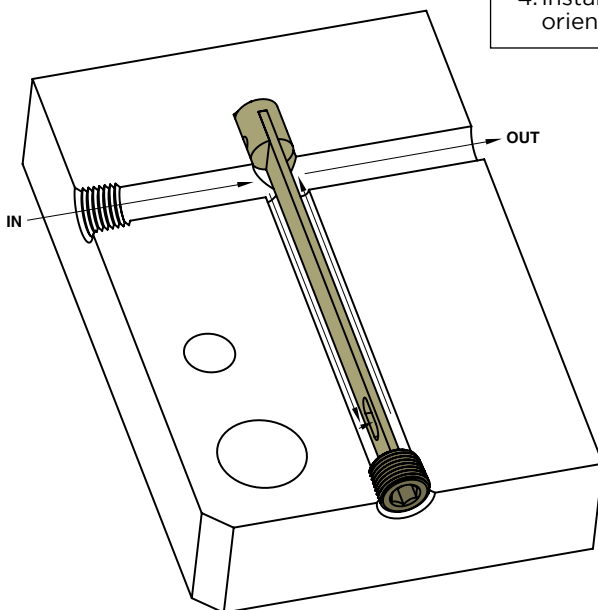
M Brass

▶ CAD insertion point

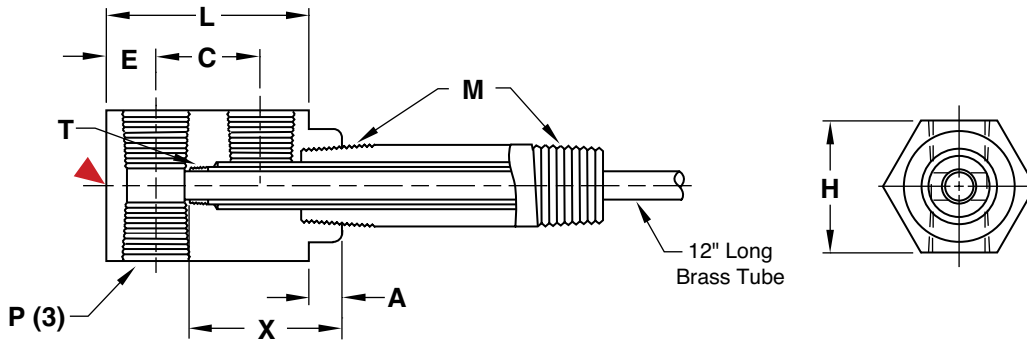
CATALOG NUMBER	P PIPE PLUG SIZE (NPT)	OAL (REF)	B	W -.005 -.010	S	SL	SW	C	E	SET SCREW SIZE (2)
RFB06L8	1/16	8.16	.057	.250	.44	.18	.13	.38	.16	#4-40 x 3/32
RFB12L8	1/8	8.23	.057	.312	.44	.22	.16	.50	.23	#4-40 x 3/32
RFB25L10	1/4	10.25	.085	.437	.62	.35	.19	.62	.25	#8-32 x 1/8
RFB37L12	3/8	12.28	.093	.562	.62	.41	.28	.75	.28	#10-32 x 3/16
RFB50L16	1/2	16.28	.093	.687	.75	.50	.31	.75	.28	1/4-20 x 3/16
RFB75L20	3/4	20.38	.093	.937	.75	.77	.44	.87	.38	1/4-20 x 3/8
RFB100L24	1	24.38	.093	1.125	.87	1.00	.50	.87	.38	1/4-20 x 3/8
RFB125L24	1-1/4	24.50	.093	1.484	1.35	1.22	.50	1.00	.50	1/4-20 x 1/2

INSTALLATION GUIDELINES

1. Install the Reverse Flow Baffle into the waterline and measure the distance the Baffle extends out of the plate, "M" as shown below.
2. Remove the Reverse Flow Plug and cut the measured length from the end of the Baffle including any recess required.
3. Re-attach the Reverse Flow Plug to the Baffle using the two set screws.
4. Install the assembly into the water line, ensuring a tight seal and proper orientation.



CASCADES
NIPPLE TYPE



M Head: Brass, Tube: Brass, 2" Long Pipe Nipple: Stainless Steel

▶ CAD insertion point

CATALOG NUMBER	M PIPE NPT	P IN/OUT NPT	H	E	C	A	L	T	BRASS TUBE CATALOG # (INCLUDED)	X TUBE END	HEAD ONLY CATALOG NUMBER
NC1816	1/8	1/16	.75	.21	.50	.28	.937	#10-32	T187L12	.90	NCH1816
NC1818	1/8	1/8	.87	.32	.68	.28	1.343	#10-32	T187L12	1.06	NCH1818
NC18181	1/8	1/8	.87	.32	1.00	.28	1.656	#10-32	T187L12	1.18	NCH18181
NC1418	1/4	1/8	1.00	.32	.68	.21	1.343	1/4-28	T250L12	1.05	NCH1418
NC1414	1/4	1/4	1.00	.32	.68	.21	1.343	1/4-28	T250L12	1.08	NCH1414
NC14181	1/4	1/8	1.00	.32	1.00	.43	1.656	1/4-28	T250L12	1.44	NCH14181
NC14141	1/4	1/4	1.00	.32	1.00	.43	1.656	1/4-28	T250L12	1.44	NCH14141
NC3818	3/8	1/8	1.00	.34	1.00	.40	1.687	5/16-24	T312L12	1.44	NCH3818
NC3814	3/8	1/4	1.00	.34	1.00	.40	1.687	5/16-24	T312L12	1.44	NCH3814
NC1214	1/2	1/4	1.25	.40	1.00	.56	1.812	7/16-20	T437L12	1.80	NCH1214
NC3438	3/4	3/8	1.50	.50	1.25	.75	2.250	5/8-18	T625L12	2.20	NCH3438

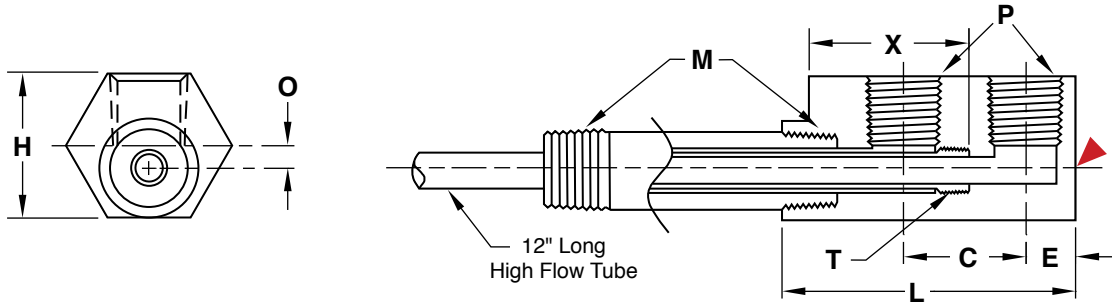
Brass pipe plug included.

ALTERNATIVE CONFIGURATIONS AVAILABLE

- Cascade Heads are available with thread sizes to accept High Flow Tubes. To order, specify -HFT at the end of the catalog number for Cascade assemblies or for Heads only. Ex. NC1818-HFT or NCH1818-HFT. (Note: NC3438 is not available with the High Flow Tube option.)
- Cascade heads are available manufactured from stainless steel. To order, add "-SS" to the end of the catalog number for Cascade assemblies or for Heads only. Ex. NC1818-SS or NCH1818-SS
- These Cascades can also be used with Adjustable Hex Nipples instead of Pipe Nipples. Refer to page E-28 for available sizes and lengths.
- For complete Tube specifications, refer to page E-16.



CASCADES
HIGH FLOW



M Head: Brass, Tube: Brass, 2" Long Pipe Nipple: Stainless Steel

▶ CAD insertion point

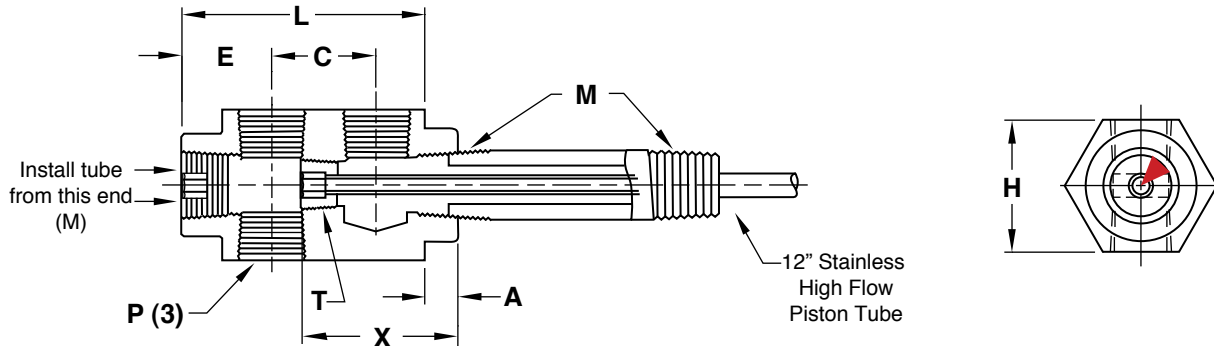
CATALOG NUMBER	M PIPE NPT	P IN/OUT NPT	H	O OFFSET	E	C	L	T TUBE THREAD	HIGH FLOW TUBE CATALOG # (INCLUDED)	X TUBE END	HEAD ONLY CATALOG NUMBER
HFC1616	1/16	1/16	.62	.094	.25	.50	1.25	#10-32	HFT125L12	.88	HFH1616
HFC1818	1/8	1/8	.75	.094	.31	.68	1.62	1/4-28	HFT187L12	1.14	HFH1818
HFC18181	1/8	1/8	.75	.094	.31	1.00	1.93	1/4-28	HFT187L12	1.15	HFH18181
HFC1414	1/4	1/4	1.00	.156	.34	.68	1.87	5/16-24	HFT250L12	1.30	HFH1414
HFC14141	1/4	1/4	1.00	.156	.34	1.00	2.18	5/16-24	HFT250L12	1.55	HFH14141
HFC3814	3/8	1/4	1.12	.125	.34	1.00	2.25	7/16-20	HFT375L12	1.64	HFH3814
HFC1214	1/2	1/4	1.37	.125	.37	1.00	2.37	1/2-20	HFT437L12	1.77	HFH1214

ALTERNATIVE CONFIGURATIONS AVAILABLE

- For High Flow Cascade assemblies with a stainless steel head, add "-SS" to the end of the catalog number. Ex. HFC1616-SS or HFC3814-SS
- For High Flow Cascade Heads manufactured out of stainless steel, add "-SS" to the end of the head catalog number. Ex. HFH1414-SS or HFH1616-SS
- High Flow Cascades can also be used with Adjustable Hex Nipples instead of Stainless Nipples. Refer to page E-28 for available sizes and lengths.
- For complete High Flow Tube specifications, refer to page E-15.

CASCADES

REAR LOADING NIPPLE



M Head: Brass, Tube & Pipe Nipple: Stainless Steel

▶ CAD insertion point

CATALOG NUMBER	M PIPE NPT	P IN/OUT NPT	H	E	C	A	L	PISTON TUBE CATALOG # (INCLUDED)	T	X TUBE END	HEAD ONLY CATALOG NUMBER
RLNC1618	1/8	1/16	3/4	.500	5/8	9/32	1.625	PT06-187L12	1/16	.93	RLCNH1618
RLNC1818	1/8	1/8	7/8	.609	11/16	9/32	1.960	PT06-187L12	1/16	1.08	RLCNH1818
RLNC18181	1/8	1/8	7/8	.609	1	9/32	2.218	PT06-187L12	1/16	1.39	RLCNH18181
RLNC1414	1/4	1/4	1	.781	1	7/16	2.562	PT12-250L12	1/8	1.44	RLCNH1414
RLNC1438	3/8	1/4	1	.781	1	7/16	2.562	PT25-312L12	1/4	1.50	RLCNH1438

ALTERNATIVE CONFIGURATIONS AVAILABLE

- For Cascade assemblies with a stainless steel head, add “-SS” to the end of the catalog number. Ex. RLNC1618-SS or RLNC18181-SS
- For Cascade Heads manufactured out of stainless steel, add “-SS” to the end of the head catalog number. Ex. RLCNH1618-SS or RLCNH18181-SS
- For complete Piston Tube specifications and longer lengths, refer to page E-16.

APPLICATION GUIDELINES

- Rear Loading Nipple Cascades allow easy access to the Piston Tube.
- Enables positive adjustment of inner tube at assembly.
- Includes 12” long Piston Tube and 2” long Stainless Pipe Nipple.

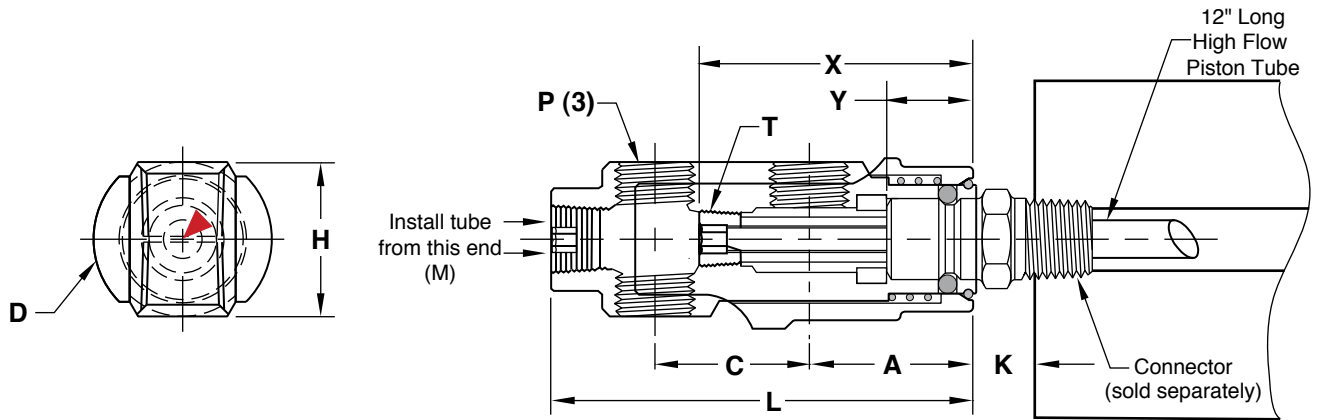
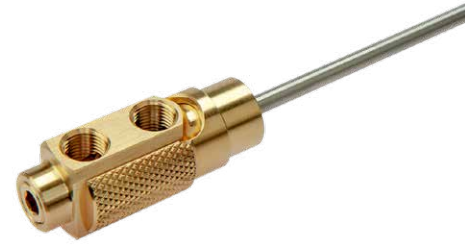


CASCADES

REAR LOAD QUICK COUPLER

APPLICATION GUIDELINES

- Rear Load Quick Coupler Cascades allow access to the inner cooling tube without removing the cascade assembly.
- Can be installed and removed without disconnecting cooling lines.



M Head: Brass, Tube: Stainless Steel, Seals: Viton

▶ CAD insertion point

CATALOG NUMBER	CONNECTOR SERIES	M PLUG SIZE NPT	P IN/OUT NPT	C	A	H	D	L	PISTON TUBE CATALOG # (INCLUDED)	T	X TUBE END	Y	HEAD ONLY CATALOG NUMBER
RLQC1814	200	1/8	1/8	11/16	31/32	13/16	7/8	2.187	PT06-187L12	1/16	1.45	.370	RLQCH1814
RLQC1815	200	1/8	1/8	1	31/32	13/16	7/8	2.500	PT06-187L12	1/16	1.54	.370	RLQCH1815
RLQC1418	300	1/4	1/4	1	1-5/32	1	1-1/8	2.937	PT12-250L12	1/4	1.89	.590	RLQCH1418
RLQC1422	500	1/2	1/4	1-1/4	1-3/8	1-1/4	1-3/8	3.687	PT37-437L12	3/8	2.25	.730	RLQCH1422
RLQC3822	500	1/2	3/8	1-1/4	1-3/8	1-1/4	1-3/8	3.687	PT37-437L12	3/8	2.25	.730	RLQCH3822

Includes 12" long Piston Tube.

CATALOG NUMBER	CONNECTOR	K MIN.
RLQC1814 RLQC1815	251	.32
	252	.43
	253	.49
RLQC1418	351*	.34
	352	.42
	353	.45
	354	.57
RLQC1422 RLQC3822	553**	.55
	554	.54
	556	.57

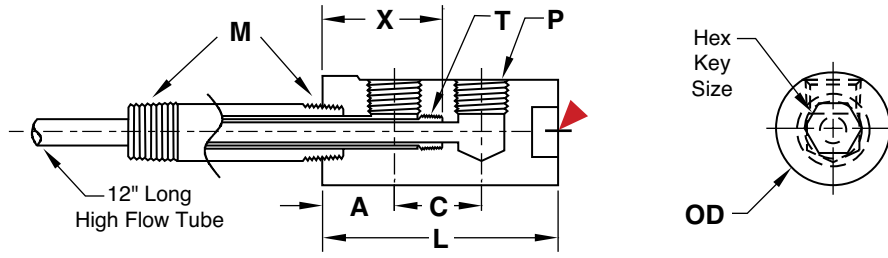
ALTERNATIVE CONFIGURATIONS AVAILABLE

- For Cascade assemblies with a stainless steel head, add "-SS" to the end of the catalog number. Ex. RLQC1814-SS or RLQC1418-SS
- For Cascade Heads manufactured out of stainless steel, add "-SS" to the end of the head catalog number. Ex. RLQCH1814-SS or RLQCH1418-SS
- For complete Piston Tube specifications and longer lengths, refer to page E-16.

* Uses High Flow Tube PT12-187

** Uses High Flow Tube PT37-375

CASCADES
HEX KEY



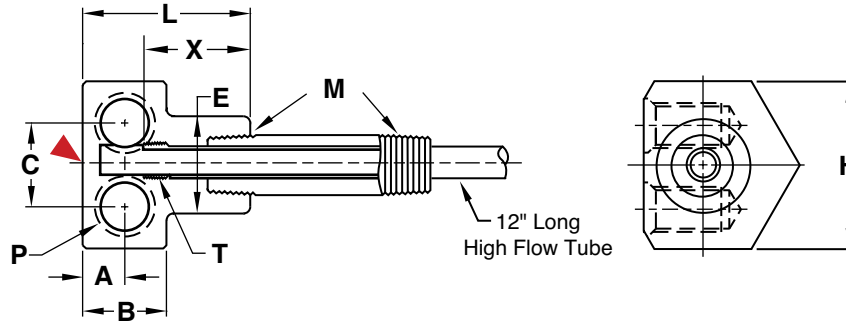
M Head: Brass, Tube: Stainless Steel, 2" Long Pipe Nipple: Stainless Steel

CATALOG NUMBER	M PIPE NPT	P IN/OUT NPT	L	C	A	HEX KEY SIZE	OD	HIGH FLOW TUBE CATALOG # (INCLUDED)	T	NOMINAL CLEARANCE DRILL	X TUBE END	HEAD ONLY CATALOG NUMBER
HKC1616	1/16	1/16	1.625	.56	.50	5/16	.610	HFT125L12	#10-32	5/8	.89	HKCH1616
HKC1816	1/8	1/16	1.687	.56	.56	3/8	.735	HFT187L12	1/4-28	3/4	.98	HKCH1816
HKC1818	1/8	1/8	1.875	.68	.56	3/8	.860	HFT187L12	1/4-28	7/8	1.00	HKCH1818
HKC18181	1/8	1/8	2.187	1.00	.56	3/8	.860	HFT187L12	1/4-28	7/8	1.20	HKCH18181
HKC1418	1/4	1/8	2.187	.68	.81	1/2	.985	HFT250L12	5/16-24	1	1.32	HKCH1418
HKC14181	1/4	1/8	2.500	1.00	.81	1/2	.985	HFT250L12	5/16-24	1	1.38	HKCH14181
HKC1414	1/4	1/4	2.312	.68	.87	1/2	.985	HFT250L12	5/16-24	1	1.33	HKCH1414
HKC14141	1/4	1/4	2.625	1.00	.87	1/2	.985	HFT250L12	5/16-24	1	1.48	HKCH14141
HKC3814	3/8	1/4	2.625	1.00	.87	1/2	.985	HFT312L12	3/8-24	1	1.56	HKCH3814
HKC1214	1/2	1/4	2.812	1.00	1.00	1/2	1.235	HFT375L12	7/16-20	1-1/4	1.73	HKCH1214

Note: HKC1616 includes a Brass Pipe Nipple

▶ CAD insertion point

COMPACT



M Head: Brass, Tube: Stainless Steel, 2" Long Pipe Nipple: Stainless Steel

▶ CAD insertion point

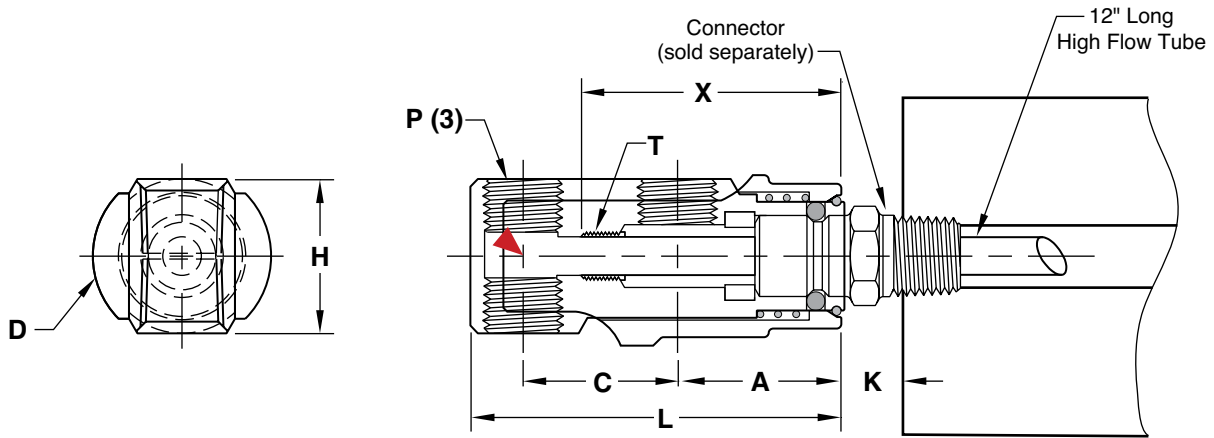
CATALOG NUMBER	M PIPE NPT	P IN/OUT NPT	H	A	B	C	E	L	HIGH FLOW TUBE CATALOG # (INCLUDED)	T	X TUBE END	HEAD ONLY CATALOG NUMBER
CC1816	1/8	1/16	.93	.21	.437	.50	.625	1.00	HFT187L12	1/4-28	.60	CCH1816
CC1418	1/4	1/8	1.25	.31	.625	.68	.750	1.25	HFT250L12	5/16-24	.82	CCH1418
CC1414	1/4	1/4	1.50	.37	.750	.75	.875	1.50	HFT250L12	5/16-24	.90	CCH1414
CC3814	3/8	1/4	1.50	.37	.750	.75	1.000	1.50	HFT312L12	3/8-24	.92	CCH3814
CC1214	1/2	1/4	1.75	.37	.750	1.0	1.187	1.75	HFT375L12	7/16-20	1.13	CCH1214
CC3438	3/4	3/8	2	.437	.875	1.125	1.375	1.875	HFT500L12	9/16-18	1.21	CCH3438

ALTERNATIVE CONFIGURATIONS AVAILABLE

- For Cascade assemblies with a stainless steel head, add "-SS" to the end of the catalog number. Ex. CC3814-SS or HKC1214-SS
- For Cascade Heads manufactured out of stainless steel, add "-SS" to the end of the head catalog number. Ex. CCH1418-SS or HKCH1214-SS
- Both the Hex Key and Compact Cascades can also be used with Adjustable Hex Nipples instead of Stainless Nipples. Refer to page E-28 for available sizes and lengths.
- For complete High Flow Tube specifications, refer to page E-15.



CASCADES QUICK COUPLER



M Cascade Head: Brass, Tube: Stainless Steel, Seals: Viton

▶ CAD insertion point

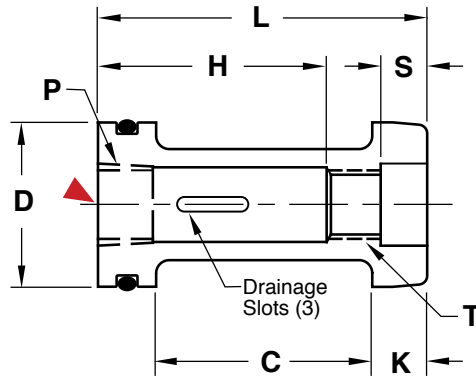
CATALOG NUMBER	CONNECTOR SERIES	P PIPE TAP SIZE NPT	C	A	H	D	L	HIGH FLOW TUBE CATALOG # (INCLUDED)	T	X TUBE END	HEAD ONLY CATALOG NUMBER
QC1819	200	1/8	.687	.968	.812	.875	1.937	HFT187L12	1/4-28	1.45	QCH1819
QC1822	200	1/8	1.000	.968	.812	.875	2.250	HFT187L12	1/4-28	1.54	QCH1822
QC1421	300	1/4	.687	1.156	1.000	1.125	2.187	HFT250L12	5/16-24	1.63	QCH1421
QC1425	300	1/4	1.000	1.156	1.000	1.125	2.500	HFT250L12	5/16-24	1.70	QCH1425
QC1431	500	1/4	1.250	1.375	1.250	1.375	3.125	HFT437L12	1/2-20	2.20	QCH1431
QC3831	500	3/8	1.250	1.375	1.250	1.375	3.125	HFT437L12	1/2-20	2.20	QCH3831

Longer High Flow Tubes and complete tube specifications can be found on page E-15.

CATALOG NUMBER	CONNECTOR	K MIN.
QC1819 QC1822	251	.32
	252	.43
	253	.49
QC1421 QC1425	351*	.34
	352	.42
	353	.45
QC1431 QC3831	354	.57
	553**	.55
	554	.54
	556	.57

* Uses High Flow Tube HFTJ187.
** Uses High Flow Tube HFTJ375.

BUBBLER BASE™



M Brass with Viton O-Ring

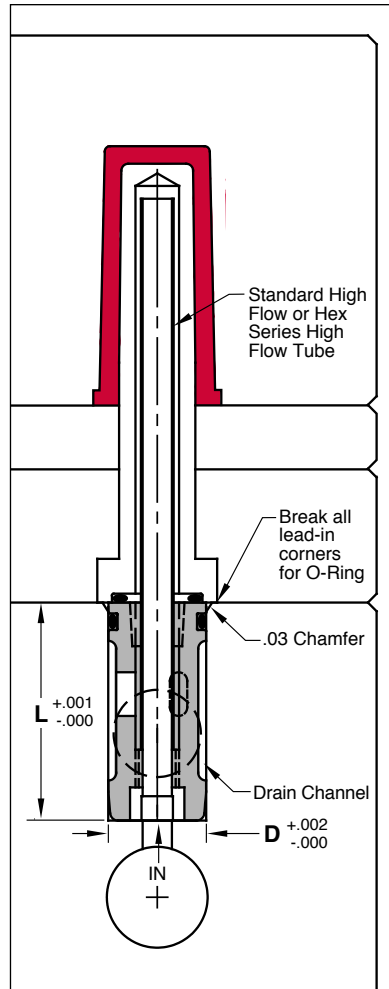
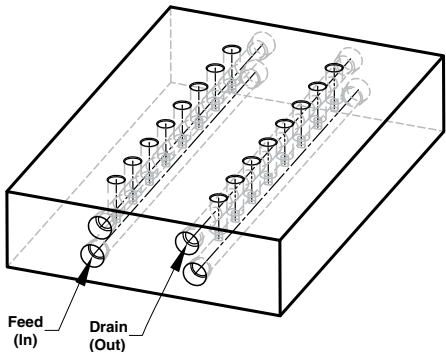
▶ CAD insertion point

CATALOG NUMBER	D	L	C	K	S	H STOP FOR HIGH FLOW TUBE	T	P PIPE THREAD FOR REMOVAL	COMPATIBLE HIGH FLOW TUBE	COMPATIBLE HEX SERIES TUBE
BBL05	.374	.750	.35	.19	.160	.45	#5-44	#10-32	HFT078 / HFT094	HEXT078 / HEXT094
BBL10	.436	1.000	.55	.23	.190	.61	#10-32	1/4-28	HFTJ078 / HFT125	HEXTJ094 / HEXT125
BBL25	.560	1.250	.72	.27	.255	.72	1/4-28	1/16-27 NPT	HFTJ125 / HFT187	HEXTJ125 / HEXT187
BBL31	.748	1.500	.98	.27	.285	.92	5/16-24	1/8-27 NPT	HFTJ187 / HFT250	HEXTJ187 / HEXT250

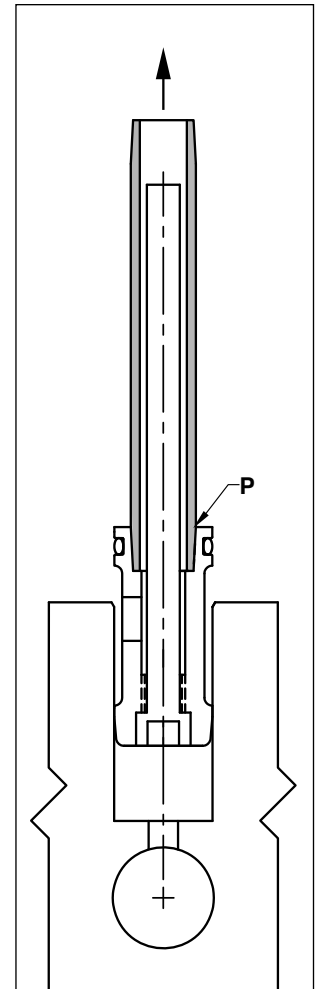
High Flow Tubes and Hex Series Tubes are sold separately on page E-15.

APPLICATION GUIDELINES

- The Bubbler Base allows for positive positioning of cooling tubes over previous methods.
- The compact design enables minimal center-to-center pin locations.
- Each Bubbler Base includes the O-Ring to ensure a positive seal within the core pin.
- Maximum temperature: 400 °F (200 °C)
- Utilize the largest diameter tube possible and match the inlet diameter's area.
- Core Pin diameter head should be large enough to incorporate a standard O-ring to seal around the tube.
- Water line location can be anywhere within the relief channel.
- To remove the Bubbler Base/Tube without damage, slip a pipe nipple around the tube that matches the "P" thread size, and fasten into the base as shown.
- The Bubbler Base can be removed by hand or by wrench on the pipe nipple (P).
- The quantity of Bubbler Bases and Tubes in line is dependent upon the mold design application and waterline calculations. For assistance in determining the optimal waterline circuit, please contact tech@procomps.com.



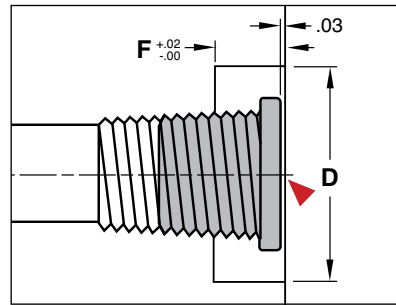
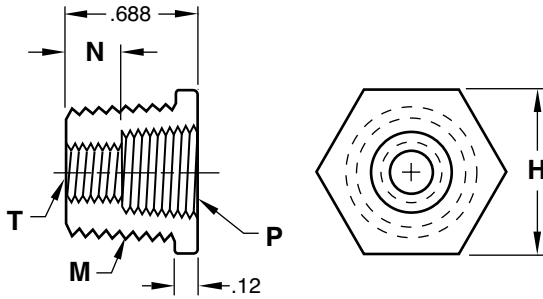
Application



Maintenance/Removal



INLET CASCADE™ CASCADE TUBE FITTING

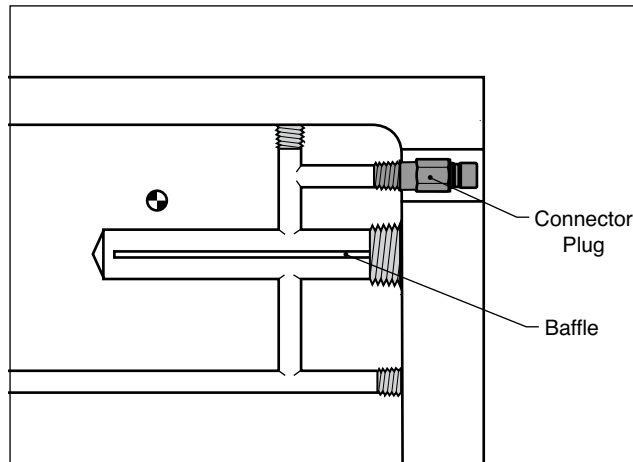


M 303 Stainless Steel **H** 18-22 HRC

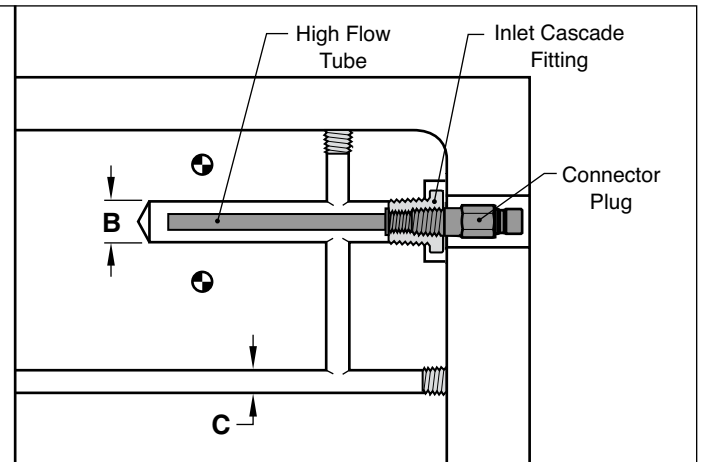
▶ CAD insertion point

CATALOG NUMBER	M WATERLINE NPT	P NPT	T TUBE THREAD	N	H HEX	D HEX CLEARANCE	F HEX C'BORE	COMPATIBLE HIGH FLOW TUBE	B DIA.	C DIA.	RECOMMENDED CONNECTOR PLUG
CF25	1/4	1/8	5/16-24	.33	.56	1.00	.430	HFT250	7/16	5/16	251, 351
CF37	3/8	1/4	3/8-24	.24	.68	1.12	.430	HFT312	9/16	7/16	352
CF50	1/2	3/8	7/16-20	.24	.87	1.50	.330	HFT375	11/16	9/16	553

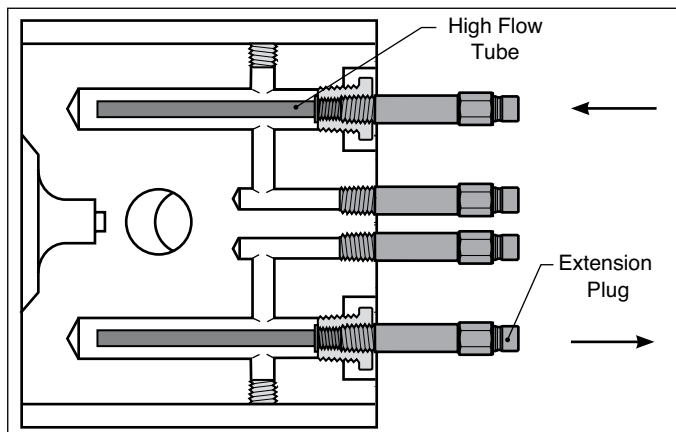
Previous Method



Inlet Cascade Method



Slide Application

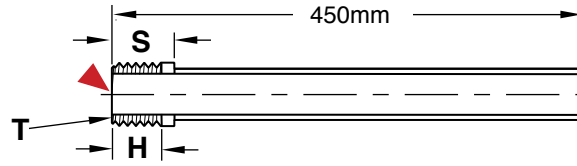


APPLICATION GUIDELINES

- The Inlet Cascade Fitting can be used when waterline space is limited, such as under a runner and between ejector pins or to provide a water circuit in a slide.
- The Inlet Cascade Fitting attaches to standard Tubes and Extension or Connector Plugs, eliminating the machining required for an extra "in" line to achieve consistent cooling.

HIGH FLOW TUBES

METRIC



M Stainless Steel

▶ CAD insertion point

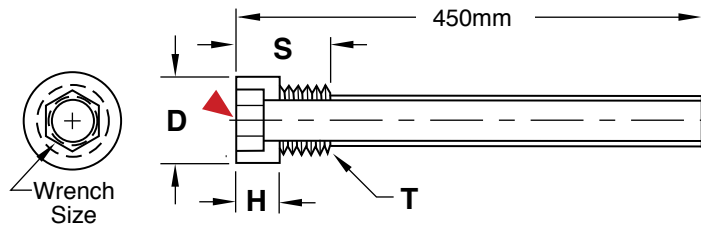
CATALOG NUMBER	TUBE O.D.	TUBE I.D.	T	S SHOULDER LENGTH	H THREAD LENGTH
HFTM18L450	1.8	1.5	M4 x .7	5	4
HFTM23L450	2.3	1.9	M5 x .8	6	5
HFTM32L450	3.2	2.8	M6 x 1.0	7	6
HFTM48L450	4.8	4.2	M8 x 1.25	10	8
HFTM64L450	6.4	5.8	M10 x 1.5	12	10
HFTM79L450	7.9	7.3	M12 x 1.75	14	12

ALTERNATIVE CONFIGURATIONS AVAILABLE

- Tubes can be ordered cut to a specific length or provided in longer lengths. To order, replace the length on any given catalog number with the desired length. Ex: HFTM79L200.

HEX SERIES TUBES

METRIC



M Stainless Steel

▶ CAD insertion point

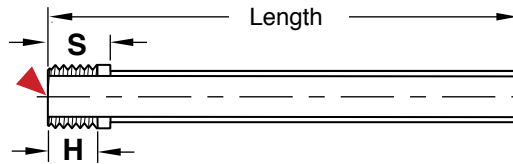
CATALOG NUMBER	TUBE O.D.	TUBE I.D.	T	S SHOULDER LENGTH	D	H HEAD HEIGHT	WRENCH SIZE
HEXM18L450	1.8	1.5	M4 x .7	8	5	4	3
HEXM23L450	2.3	1.9	M5 x .8	10	6	5	4
HEXM32L450	3.2	2.8	M6 x 1.0	12	8	6	5
HEXM48L450	4.8	4.2	M8 x 1.25	16	10	8	6
HEXM64L450	6.4	5.8	M10 x 1.5	16	12	8	6
HEXM79L450	7.9	7.3	M12 x 1.75	16	14	8	8

ALTERNATIVE CONFIGURATIONS AVAILABLE

- Tubes can be ordered cut to a specific length or provided in longer lengths. To order, replace the length on any given catalog number with the desired length. Ex: HEXM79L200.



HIGH FLOW TUBES



M Stainless Steel

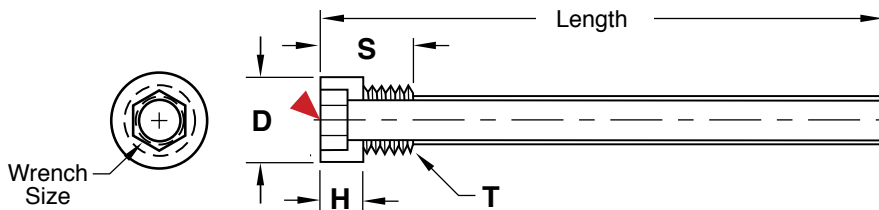
▶ CAD insertion point

TUBE O.D.	TUBE I.D.	THREAD SIZE	H	S	12" LENGTH	18" LENGTH	24" LENGTH	36" LENGTH
.072	.060	#5-44	.125	.140	HFT078L12	HFT078L18	HFT078L24	HFT078L36
		#10-32	.156	.203	HFTJ078L12	HFTJ078L18	HFTJ078L24	HFTJ078L36
.090	.076	#5-44	.125	.140	HFT094L12	HFT094L18	HFT094L24	HFT094L36
		#10-32	.156	.203	HFTJ094L12	HFTJ094L18	HFTJ094L24	HFTJ094L36
.125	.109	#10-32	.156	.203	HFT125L12	HFT125L18	HFT125L24	HFT125L36
		1/4-28	.203	.255	HFTJ125L12	HFTJ125L18	HFTJ125L24	HFTJ125L36
.187	.167	1/4-28	.203	.255	HFT187L12	HFT187L18	HFT187L24	HFT187L36
		5/16-24	.235	.290	HFTJ187L12	HFTJ187L18	HFTJ187L24	HFTJ187L36
.250	.230	5/16-24	.235	.290	HFT250L12	HFT250L18	HFT250L24	HFT250L36
		3/8-24	.296	.359	HFTJ250L12	HFTJ250L18	HFTJ250L24	HFTJ250L36
.312	.288	3/8-24	.296	.359	HFT312L12	HFT312L18	HFT312L24	HFT312L36
		7/16-20	.359	.437	HFTJ312L12	HFTJ312L18	HFTJ312L24	HFTJ312L36
.365	.340	7/16-20	.359	.437	HFT375L12	HFT375L18	HFT375L24	HFT375L36
		1/2-20	.421	.500	HFTJ375L12	HFTJ375L18	HFTJ375L24	HFTJ375L36
.427	.397	1/2-20	.421	.500	HFT437L12	HFT437L18	HFT437L24	HFT437L36
		9/16-18	.421	.500	HFTJ437L12	HFTJ437L18	HFTJ437L24	HFTJ437L36
.500	.444	9/16-18	.421	.531	HFT500L12	HFT500L18	HFT500L24	HFT500L36
		5/8-18	.421	.531	HFTJ500L12	HFTJ500L18	HFTJ500L24	HFTJ500L36

APPLICATION GUIDELINES

- High Flow Tubes are for use with High Flow Cascade Heads, Compact Cascade Heads, Quick Coupling Cascade Heads and Hex Key Cascade Heads.
- Tubes can be ordered cut to a specific length or provided in longer lengths. To order, replace the length on any given catalog number with the desired length. Ex. HFT125L14.5

HEX SERIES TUBES



M Stainless Steel

▶ CAD insertion point

TUBE O.D.	TUBE I.D.	T THREAD	WRENCH SIZE	S	D	H HEAD HEIGHT	12" LENGTH	18" LENGTH	24" LENGTH	36" LENGTH
.072	.060	#5-44	1/8	.312	.182	.156	HEXT078L12	HEXT078L18	HEXT078L24	HEXT078L36
		#10-32	1/8	.406	.245	.187	HEXTJ078L12	HEXTJ078L18	HEXTJ078L24	HEXTJ078L36
.090	.076	#5-44	1/8	.312	.182	.156	HEXT094L12	HEXT094L18	HEXT094L24	HEXT094L36
		#10-32	1/8	.406	.245	.187	HEXTJ094L12	HEXTJ094L18	HEXTJ094L24	HEXTJ094L36
.125	.109	#10-32	5/32	.406	.245	.187	HEXT125L12	HEXT125L18	HEXT125L24	HEXT125L36
		1/4-28	5/32	.406	.307	.250	HEXTJ125L12	HEXTJ125L18	HEXTJ125L24	HEXTJ125L36
.187	.167	1/4-28	3/16	.500	.307	.250	HEXT187L12	HEXT187L18	HEXT187L24	HEXT187L36
		5/16-24	1/4	.562	.370	.281	HEXTJ187L12	HEXTJ187L18	HEXTJ187L24	HEXTJ187L36
.250	.230	5/16-24	1/4	.562	.370	.281	HEXT250L12	HEXT250L18	HEXT250L24	HEXT250L36
		3/8-24	5/16	.625	.495	.312	HEXTJ250L12	HEXTJ250L18	HEXTJ250L24	HEXTJ250L36
.312	.288	3/8-24	5/16	.625	.495	.312	HEXT312L12	HEXT312L18	HEXT312L24	HEXT312L36
		1/2-20	3/8	.750	.620	.375	HEXTJ312L12	HEXTJ312L18	HEXTJ312L24	HEXTJ312L36

ALTERNATIVE CONFIGURATIONS AVAILABLE

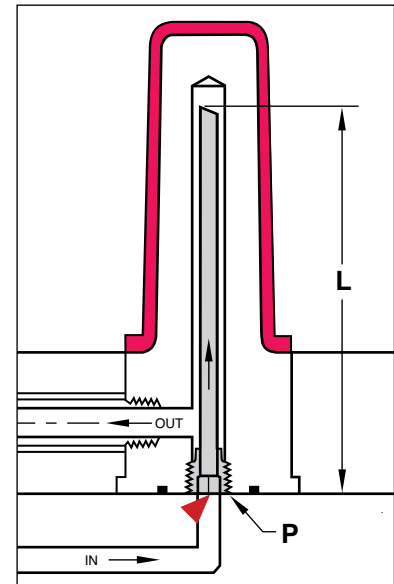
- Tubes can be ordered cut to a specific length or provided in longer lengths. To order, replace the length on any given catalog number with the desired length. Ex: HEXT312L14.5.

PISTON TUBES



M Tube: High Flow Stainless Steel, Pipe Plug: Stainless Steel ▶ CAD insertion point

P NPT	TUBE O.D.	TUBE I.D.	12" LENGTH	18" LENGTH	24" LENGTH	36" LENGTH	48" LENGTH
1/16	.072	.060	PT06-078L12	PT06-078L18	PT06-078L24	PT06-078L36	PT06-078L48
	.090	.076	PT06-094L12	PT06-094L18	PT06-094L24	PT06-094L36	PT06-094L48
	.109	.095	PT06-109L12	PT06-109L18	PT06-109L24	PT06-109L36	PT06-109L48
	.125	.109	PT06-125L12	PT06-125L18	PT06-125L24	PT06-125L36	PT06-125L48
	.187	.167	PT06-187L12	PT06-187L18	PT06-187L24	PT06-187L36	PT06-187L48
1/8	.125	.109	PT12-125L12	PT12-125L18	PT12-125L24	PT12-125L36	PT12-125L48
	.187	.167	PT12-187L12	PT12-187L18	PT12-187L24	PT12-187L36	PT12-187L48
	.250	.230	PT12-250L12	PT12-250L18	PT12-250L24	PT12-250L36	PT12-250L48
1/4	.187	.167	PT25-187L12	PT25-187L18	PT25-187L24	PT25-187L36	PT25-187L48
	.250	.230	PT25-250L12	PT25-250L18	PT25-250L24	PT25-250L36	PT25-250L48
	.312	.288	PT25-312L12	PT25-312L18	PT25-312L24	PT25-312L36	PT25-312L48
3/8	.312	.288	PT37-312L12	PT37-312L18	PT37-312L24	PT37-312L36	PT37-312L48
	.365	.340	PT37-375L12	PT37-375L18	PT37-375L24	PT37-375L36	PT37-375L48
1/2	.427	.397	PT37-437L12	PT37-437L18	PT37-437L24	PT37-437L36	PT37-437L48
	.365	.340	PT50-375L12	PT50-375L18	PT50-375L24	PT50-375L36	PT50-375L48
	.427	.397	PT50-437L12	PT50-437L18	PT50-437L24	PT50-437L36	PT50-437L48
3/4	.500	.444	PT50-500L12	PT50-500L18	PT50-500L24	PT50-500L36	PT50-500L48
	.427	.397	PT75-437L12	PT75-437L18	PT75-437L24	PT75-437L36	PT75-437L48
	.500	.444	PT75-500L12	PT75-500L18	PT75-500L24	PT75-500L36	PT75-500L48
	.625	.569	PT75-625L12	PT75-625L18	PT75-625L24	PT75-625L36	PT75-625L48



ALTERNATIVE CONFIGURATIONS AVAILABLE

- For Piston Tubes with a brass plug, specify "B" at the end of the catalog numbers for all sizes. Ex. PT25-250L12B.
- Longer lengths and Piston Tubes cut to length are available. Contact Customer Service for pricing and delivery.

BRASS TUBES



M Half-Hard Tempered Brass

TUBE O.D.	TUBE I.D.	THREAD SIZE	THREAD LENGTH	12" LENGTH	18" LENGTH	24" LENGTH	36" LENGTH
.125	.061	#5-44	.187	T125L12	T125L18	T125L24	T125L36
.187	.123	#10-32	.187	T187L12	T187L18	T187L24	T187L36
.250	.170	1/4-28	.250	T250L12	T250L18	T250L24	T250L36
.312	.210	5/16-24	.312	T312L12	T312L18	T312L24	T312L36
.375	.273	3/8-24	.375	T375L12	T375L18	T375L24	T375L36
.437	.307	7/16-20	.437	T437L12	T437L18	T437L24	T437L36
.625	.495	5/8-18	.625	T625L12	T625L18	T625L24	T625L36

ALTERNATIVE CONFIGURATIONS AVAILABLE

- To order tubes with both ends threaded, add a "T" to the end of the catalog number. Ex. T125L12T
- Tubing is available in stainless steel and threaded both ends. To order, specify "-SST" in the catalog number above. Ex. T125L12-SST. (Note: Not available in 5/8 OD.)
- Longer length tubes or tubes cut to length can be ordered by contacting Customer Service.



O-RINGS FACE SEAL



APPLICATION GUIDELINES

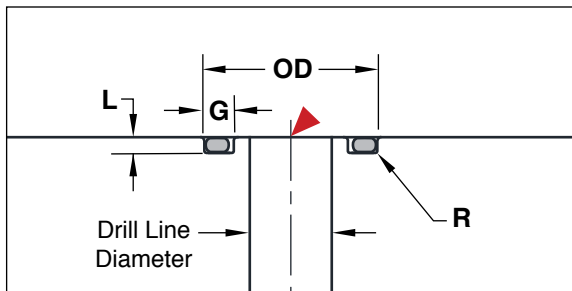
- Buna-N temperature range is -20°F to 225 °F (-28°C to 107°C)
- Viton® temperature range is 0°F to 400°F (-17°C to 204°C)
- Minimum order quantity is 25 rings per size and must be purchased in increments of 25.

▶ CAD insertion point

Face Seal Dimensions

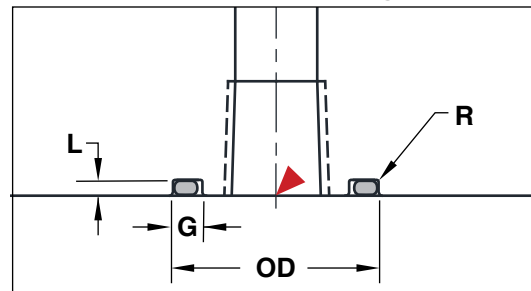
DASH NUMBER	CROSS SECTION	G	L	R
-013 through -025	1/16	.101 to .107	.050 to .054	.005 to .015
-112 through -125	3/32	.136 to .142	.074 to .080	.005 to .015

Drill Line: Face Sealing



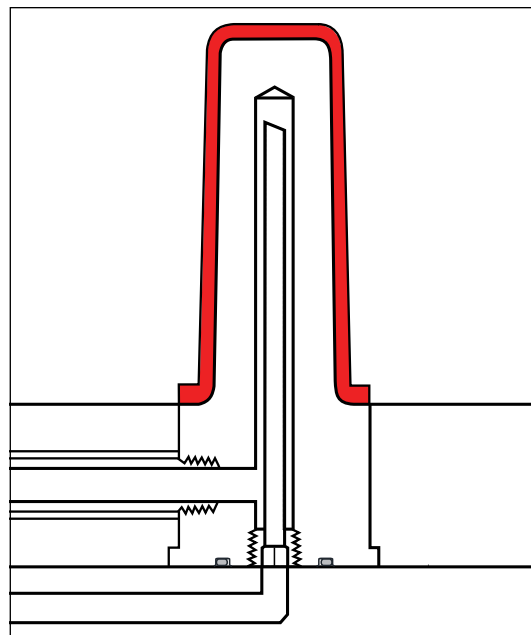
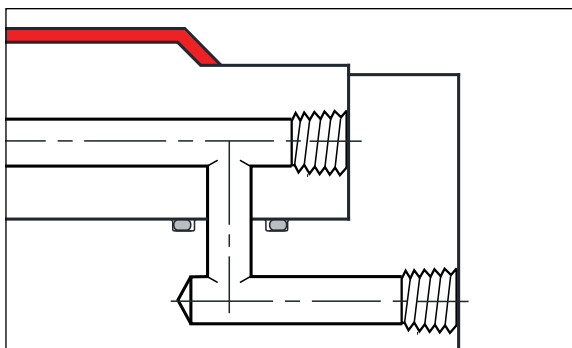
DRILL LINE DIAMETER	CATALOG NUMBER		OD
	BUNA-N	VITON	
.25 (1/4)	OR-013	OR-013-V	.566
	OR-112	OR-112-V	.693
.312 (5/16)	OR-014	OR-014-V	.629
	OR-113	OR-113-V	.755
.375 (3/8)	OR-015	OR-015-V	.691
	OR-114	OR-114-V	.818
.421 (27/64)	OR-016	OR-016-V	.754
	OR-114	OR-114-V	.818
.437 (7/16)	OR-017	OR-017-V	.816
	OR-115	OR-115-V	.880
.500 (7/16)	OR-018	OR-018-V	.879
	OR-116	OR-116-V	.943
.562 (9/16)	OR-019	OR-019-V	0.941
	OR-117	OR-117-V	1.005
.687 (11/16)	OR-021	OR-021-V	1.066
	OR-119	OR-119-V	1.130
.906 (29/32)	OR-024	OR-024-V	1.254
	OR-123	OR-123-V	1.380
.937 (15/16)	OR-025	OR-025-V	1.316
	OR-124	OR-124-V	1.443

NPT: Face Sealing



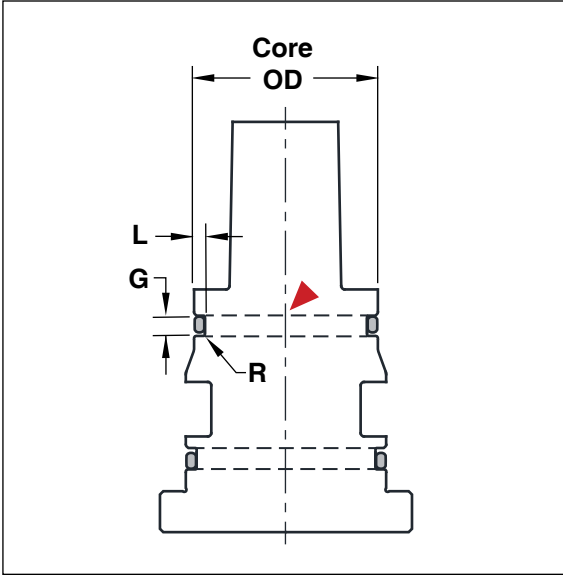
NPT	CATALOG NUMBER		OD
	BUNA-N	VITON	
1/16	OR-015	OR-015-V	.691
	OR-113	OR-113-V	.755
1/8	OR-016	OR-016-V	.754
	OR-114	OR-114-V	.818
1/4	OR-018	OR-018-V	.879
	OR-116	OR-116-V	.943
3/8	OR-020	OR-020-V	1.004
	OR-118	OR-118-V	1.068
1/2	OR-023	OR-023-V	1.191
	OR-122	OR-122-V	1.318
3/4	OR-026	OR-026-V	1.379
	OR-125	OR-125-V	1.505

Applications



O-RINGS

CORE DIAMETER SEAL



Core Seal Dimensions ▶ CAD insertion point

DASH NUMBER	CROSS SECTION	G	L	R
-014 through -048	1/16	.093 to .098	.048 to .049	.005 to .015
-114 through -157	3/32	.140 to .145	.079 to .080	.005 to .015
-208 through -247	1/8	.187 to .192	.109 to .110	.005 to .015

APPLICATION GUIDELINES

- Buna-N temperature range is -20°F to 225°F (-28°C to 107°C)
- Viton® temperature range is 0°F to 400°F (-17°C to 204°C)

To Order:

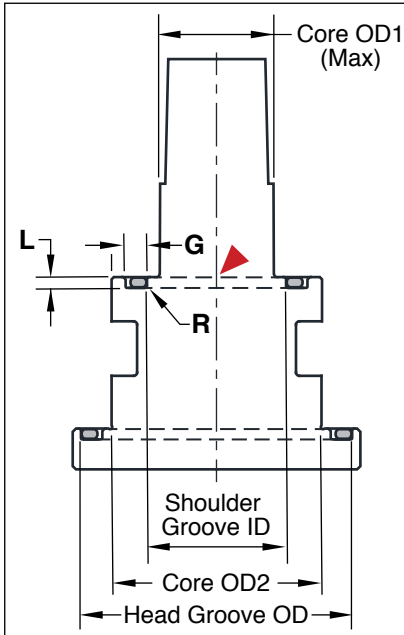
- Buna-N O-Rings: Specify the prefix "OR" before the dash number. Ex. OR-127 or OR-241.
- Viton O-Rings: Specify the prefix "OR" before the dash number and "-V" as the suffix. Ex. OR-127-V or OR-241-V.
- Minimum order quantity is 25 rings per size and must be purchased in increments of 25.

NOMINAL CORE DIAMETER	1/16 CROSS SECTION		3/32 CROSS SECTION		1/8 CROSS SECTION	
	DASH NUMBER	CORE OD +.000 - .001	DASH NUMBER	CORE OD +.000 - .001	DASH NUMBER	CORE OD +.000 - .001
5/8	-014	0.623	-	-	-	-
11/16	-015	0.685	-	-	-	-
3/4	-016	0.748	-	-	-	-
13/16	-017	0.81	-114	0.81	-	-
7/8	-018	0.873	-115	0.873	-208	0.872
15/16	-019	0.935	-116	0.935	-209	0.934
1	-020	0.998	-117	0.998	-210	0.997
1-1/16	-021	1.06	-118	1.06	-211	1.059
1-1/8	-022	1.123	-119	1.123	-212	1.122
1-3/16	-023	1.185	-120	1.185	-213	1.184
1-1/4	-024	1.248	-121	1.248	-214	1.247
1-5/16	-025	1.31	-122	1.31	-215	1.309
1-3/8	-026	1.373	-123	1.373	-216	1.372
1-7/16	-027	1.435	-124	1.435	-217	1.434
1-1/2	-028	1.498	-125	1.498	-218	1.497
1-9/16	-	-	-126	1.56	-219	1.559
1-5/8	-029	1.623	-127	1.623	-220	1.622
1-11/16	-	-	-128	1.685	-221	1.684
1-3/4	-030	1.748	-129	1.748	-222	1.747
1-13/16	-	-	-130	1.81	-	-
1-7/8	-031	1.873	-131	1.873	-223	1.872
1-15/16	-	-	-132	1.935	-	-
2	-032	1.998	-133	1.998	-224	1.997
2-1/16	-	-	-134	2.06	-	-
2-1/8	-033	2.123	-135	2.123	-225	2.122
2-3/16	-	-	-136	2.185	-	-
2-1/4	-034	2.248	-137	2.248	-226	2.247
2-5/16	-	-	-138	2.31	-	-
2-3/8	-035	2.373	-139	2.373	-227	2.372
2-7/16	-	-	-140	2.435	-	-
2-1/2	-036	2.498	-141	2.498	-228	2.497
2-9/16	-	-	-142	2.56	-	-
2-5/8	-037	2.623	-143	2.623	-229	2.622
2-11/16	-	-	-144	2.685	-	-
2-3/4	-038	2.748	-145	2.748	-230	2.747
2-13/16	-	-	-146	2.81	-	-
2-7/8	-039	2.873	-147	2.873	-231	2.872
2-15/16	-	-	-148	2.935	-	-
3	-040	2.998	-149	2.998	-232	2.997
3-1/16	-	-	-150	3.06	-	-
3-1/8	-041	3.123	-151	3.185	-233	3.122
3-1/4	-	-	-	-	-234	3.247
3-3/8	-042	3.373	-	-	-235	3.372
3-7/16	-	-	-152	3.435	-236	3.497
3-5/8	-043	3.623	-	-	-237	3.622
3-11/16	-	-	-153	3.685	-	-
3-3/4	-	-	-	-	-238	3.747
3-7/8	-044	3.873	-	-	-239	3.872
3-15/16	-	-	-154	3.935	-	-
4	-	-	-	-	-240	3.997
4-1/8	-045	4.123	-	-	-241	4.122
4-3/16	-	-	-155	4.185	-	-
4-1/4	-	-	-	-	-242	4.247
4-3/8	-046	4.373	-	-	-243	4.372
4-7/16	-	-	-156	4.435	-	-
4-1/2	-	-	-	-	-244	4.497
4-5/8	-047	4.623	-	-	-245	4.622
4-11/16	-	-	-157	4.685	-	-
4-3/4	-	-	-	-	-246	4.747
4-7/8	-048	4.873	-	-	-247	4.872



O-RINGS

CORE FACE SEAL



- ### APPLICATION GUIDELINES
- The Shoulder Groove ID is to be determined by the ID of the O-Ring and groove width.
 - The corresponding Head Groove OD is to be determined by the OD of the O-Ring and groove width.
 - Buna-N temp range: -20°F to 225°F (-28°C to 107°C)
 - Viton® temp range: 0°F to 400°F (-17°C to 204°C)

Face Seal Dimensions

CAD insertion point

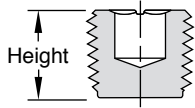
DASH NUMBER	CROSS SECTION	G GROOVE WIDTH	L	R
-025 through -046	1/16	.101 to .107	.050 to .054	.005 to .015
-123 through -157	3/32	.136 to .142	.074 to .080	.005 to .015
-217 through -245	1/8	.177 to .187	.101 to .107	.005 to .015

CORE OD1	1/16 CROSS SECTION				3/32 CROSS SECTION				1/8 CROSS SECTION						
	SHOULDER		CORE OD2	HEAD		SHOULDER		CORE OD2	HEAD		SHOULDER		CORE OD2	HEAD	
	DASH NUMBER	GROOVE ID		DASH NUMBER	GROOVE OD	DASH NUMBER	GROOVE ID		DASH NUMBER	GROOVE OD	DASH NUMBER	GROOVE ID		DASH NUMBER	GROOVE OD
1	-025	1.176	1-5/8	-033	2.129	-123	1.174	1-11/16	-136	2.193	-217	1.171	1-3/4	-	-
1-1/16	-026	1.239	1-11/16	-033	2.129	-124	1.237	1-3/4	-137	2.256	-218	1.234	1-13/16	-227	2.387
1-1/8	-027	1.301	1-3/4	-034	2.254	-125	1.299	1-13/16	-138	2.318	-219	1.296	1-7/8	-	-
1-3/16	-028	1.364	1-13/16	-034	2.254	-126	1.362	1-7/8	-139	2.381	-220	1.359	1-15/16	-228	2.512
1-1/4	-	-	1-7/8	-	-	-127	1.424	1-15/16	-140	2.443	-221	1.421	2	-	-
1-5/16	-029	1.489	1-15/16	-035	2.379	-128	1.487	2	-141	2.506	-222	1.484	2-1/16	-229	2.637
1-3/8	-	-	2	-	-	-129	1.549	2-1/16	-142	2.568	-	-	2-1/8	-	-
1-7/16	-030	1.614	2-1/16	-036	2.504	-130	1.612	2-1/8	-143	2.631	-223	1.609	2-3/16	-230	2.762
1-1/2	-	-	2-1/8	-	-	-131	1.674	2-3/16	-144	2.693	-	-	2-1/4	-	-
1-9/16	-031	1.739	2-3/16	-037	2.629	-132	1.737	2-1/4	-145	2.756	-224	1.734	2-5/16	-231	2.887
1-5/8	-	-	2-1/4	-	-	-133	1.799	2-5/16	-146	2.818	-	-	2-3/8	-	-
1-11/16	-032	1.864	2-5/16	-038	2.754	-134	1.862	2-3/8	-	-	-225	1.859	2-7/16	-232	3.012
1-3/4	-	-	2-3/8	-	-	-135	1.924	2-7/16	-148	2.943	-	-	2-1/2	-	-
1-13/16	-033	1.989	2-7/16	-039	2.879	-136	1.987	2-1/2	-149	3.006	-226	1.984	2-9/16	-233	3.137
1-7/8	-	-	2-1/2	-	-	-137	2.049	2-9/16	-150	3.068	-	-	2-5/8	-	-
1-15/16	-034	2.114	2-9/16	-040	3.004	-138	2.112	2-5/8	-	-	-227	2.109	2-11/16	-234	3.262
2	-	-	2-5/8	-	-	-139	2.174	2-11/16	-151	3.193	-	-	2-3/4	-	-
2-1/16	-035	2.239	2-11/16	-041	3.129	-140	2.237	2-3/4	-	-	-228	2.234	2-13/16	-235	3.387
2-1/8	-	-	2-3/4	-	-	-141	2.299	2-13/16	-	-	-	-	2-7/8	-	-
2-3/16	-036	2.364	2-13/16	-	-	-142	2.362	2-7/8	-	-	-229	2.359	2-15/16	-236	3.512
2-1/4	-	-	2-7/8	-	-	-143	2.424	2-15/16	-152	3.443	-	-	3	-	-
2-5/16	-037	2.489	2-15/16	-042	3.379	-144	2.487	3	-	-	-230	2.484	3-1/16	-237	3.637
2-3/8	-	-	3	-	-	-145	2.549	3-1/16	-	-	-	-	3-1/8	-	-
2-7/16	-038	2.614	3-1/16	-	-	-146	2.612	3-1/8	-153	3.693	-231	2.609	3-3/16	-238	3.762
2-1/2	-	-	3-1/8	-	-	-147	2.674	3-3/16	-	-	-	-	3-1/4	-	-
2-9/16	-039	2.739	3-3/16	-043	3.629	-148	2.737	3-1/4	-	-	-232	2.734	3-5/16	-239	3.887
2-5/8	-	-	3-1/4	-	-	-149	2.799	3-5/16	-	-	-	-	3-3/8	-	-
2-11/16	-040	2.864	3-5/16	-	-	-150	2.862	3-3/8	-	-	-233	2.859	3-7/16	-240	4.012
2-3/4	-	-	3-3/8	-	-	-151	2.924	3-7/16	-154	3.943	-	-	3-1/2	-	-
2-13/16	-041	2.989	3-7/16	-044	3.879	-	-	3-1/2	-	-	-234	2.984	3-9/16	-241	4.137
2-15/16	-	-	3-9/16	-	-	-	-	3-5/8	-	-	-235	3.109	3-11/16	-242	4.262
3	-	-	3-5/8	-	-	-	-	3-11/16	-155	4.193	-	-	3-3/4	-	-
3-1/16	-042	3.239	3-11/16	-045	4.129	-152	3.237	3-3/4	-156	4.443	-236	3.234	3-13/16	-243	4.387
3-3/16	-	-	3-13/16	-	-	-	-	3-7/8	-	-	-237	3.359	3-15/16	-244	4.512
3-5/16	-043	3.489	3-15/16	-046	4.379	-153	3.487	4	-157	4.693	-238	3.484	4-1/16	-245	4.637

- To Order:**
- Buna-N O-Rings: Specify the prefix "OR" before the dash number. Ex. OR-127 or OR-241.
 - Viton O-Rings: Specify the prefix "OR" before the dash number and "-V" as the suffix. Ex. OR-127-V or OR-241-V.
 - Minimum order quantity is 25 rings per size and must be purchased in increments of 25.

PIPE PLUGS

NPT STANDARD



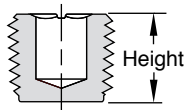
APPLICATION GUIDELINES

- Standard Plugs are flush type, 7/8" taper per foot. Oversize Plugs available with 3/4" taper per foot.
- To order oversized Pipe Plugs, add a "-O" to the end of the catalog number. Ex. BR50-O.
Note: Oversized not available in 2" Brass.

M Brass, Alloy Steel, and Stainless Steel

PIPE THREAD NPT	BRASS CATALOG NUMBER	STEEL CATALOG NUMBER	STAINLESS CATALOG NUMBER	FLUSH HEIGHT	OVERSIZE HEIGHT
1/16	BR06	ST06	SS06	.25	.31
1/8	BR12	ST12	SS12	.25	.31
1/4	BR25	ST25	SS25	.40	.43
3/8	BR37	ST37	SS37	.40	.50
1/2	BR50	ST50	SS50	.53	.56
3/4	BR75	ST75	SS75	.53	.62
1	BR100	ST100	SS100	.65	.75
1-1/4	BR125	ST125	SS125	.65	.81
1-1/2	BR150	ST150	SS150	.65	.81
2	BR200	ST200	SS200	.65	.87

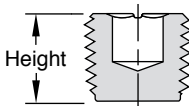
NPT STANDARD-DEEP HEX



M Brass

PIPE THREAD NPT	CATALOG NUMBER	HEIGHT
1/16	BRHD06	.289
1/8	BRHD12	.312
1/4	BRHD25	.445
3/8	BRHD37	.513
1/2	BRHD50	.625
3/4	BRHD75	.625

BSPT STANDARD



APPLICATION GUIDELINES

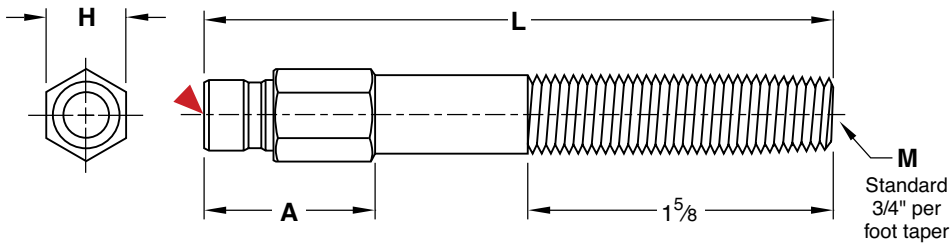
- Fits BSPT and BSPP threads.
- Identification ring present on bottom of plugs.

M Brass, Alloy Steel, and Stainless Steel

PIPE THREAD	BRASS CATALOG NUMBER	STEEL CATALOG NUMBER	STAINLESS CATALOG NUMBER	HEIGHT (MM)
1/16-28 BSPT	BR06-BSP	ST06-BSP	SS06-BSP	7
1/8-28 BSPT	BR12-BSP	ST12-BSP	SS12-BSP	8
1/4-19 BSPT	BR25-BSP	ST25-BSP	SS25-BSP	10
3/8-19 BSPT	BR37-BSP	ST37-BSP	SS37-BSP	10
1/2-14 BSPT	BR50-BSP	ST50-BSP	SS50-BSP	10
3/4-14 BSPT	BR75-BSP	ST75-BSP	SS75-BSP	13
1-11 BSPT	BR100-BSP	-	-	14
1 1/4-11 BSPT	BR125-BSP	-	-	16



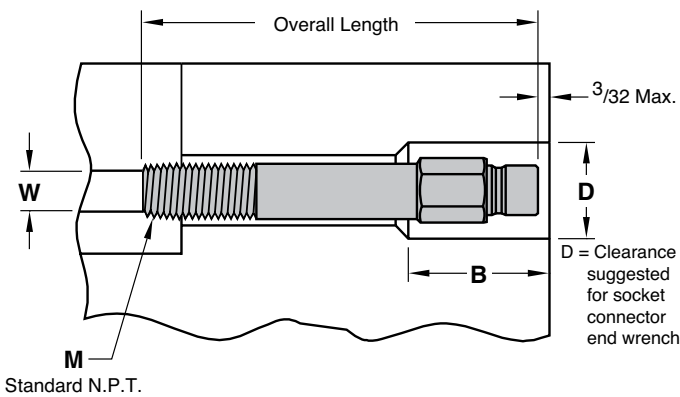
EXTENSION PLUGS



M Brass

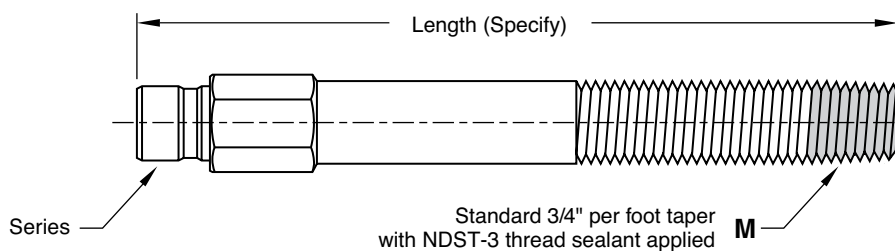
▶ CAD insertion point

EXTENSION SERIES	M PIPE THREAD	D	B	W (REF)
250	1/16	.75	1.00	1/4
251	1/8	.87	1.25	5/16
252	1/4	1.00	1.50	7/16
253	3/8	1.12	1.50	9/16
350	1/16	1.00	1.25	1/4
351	1/8	1.00	1.25	5/16
352	1/4	1.00	1.50	7/16
353	3/8	1.12	1.50	9/16
354	1/2	1.50	1.75	11/16
553	3/8	1.37	1.62	9/16
554	1/2	1.50	1.75	11/16



ALTERNATIVE CONFIGURATIONS AVAILABLE

- Note: Standard Series Extension Plugs are shown on page E-22. Keyed Connect Extension Plugs are shown on page E-23.
- Stainless Steel Extension Plugs are also available. Specify "-SS" at the end of the catalog number. Ex. 252L5.5-SS or 353L4-SS
- Extension Plugs can be obtained made to BSPT specs. The threads are BSPT, and all other dimensions are inch nominal per the chart on page E-22. To order, specify "-BSP" at the end of the catalog number. Ex. 252L5.5-BSP
- ND ST-3 Thread Sealant can be applied to any Extension Plug. To order, specify "-ST" at the end of the catalog number. Ex. 252L5.5-ST or 252L5.5-SS-ST
- Extension Plugs can be ordered cut to length, in any quantity, as shown below. All Extension Plugs cut to length have sealant applied to the tapered end for convenience. To order, specify series and NPT prefix with required length. Ex. 352L6.53



EXTENSION PLUGS

STANDARD SERIES



• Use with standard Socket Connectors shown on page E-25 only.

200 Series 1/4" HOLE					300 Series 3/8" HOLE					500 Series 1/2" HOLE				
CATALOG NUMBER	L LENGTH	M NPT	H HEX SIZE	A	CATALOG NUMBER	L LENGTH	M NPT	H HEX SIZE	A	CATALOG NUMBER	L LENGTH	M NPT	H HEX SIZE	A
1/16" PIPE EXTENSIONS														
250L2.5	2.5	1/16	.37	.68	350L2.5	2.5	1/16	.56	.87	AVAILABLE ON REQUEST				
250L4	4.0	1/16	.37	.81	350L4	4.0	1/16	.56	1.00					
250L5.5	5.5	1/16	.37	.81	350L5.5	5.5	1/16	.56	1.00					
250L7	7.0	1/16	.37	.81	350L7	7.0	1/16	.56	1.00					
1/8" PIPE EXTENSIONS														
251L2.5	2.5	1/8	.43	.68	351L2.5	2.5	1/8	.56	.87	AVAILABLE ON REQUEST				
251L4	4.0	1/8	.43	1.00	351L4	4.0	1/8	.56	1.00					
251L5.5	5.5	1/8	.43	1.00	351L5.5	5.5	1/8	.56	1.00					
251L7	7.0	1/8	.43	1.00	351L7	7.0	1/8	.56	1.00					
251L8.5	8.5	1/8	.43	1.00	351L8.5	8.5	1/8	.56	1.00					
251L10	10.0	1/8	.43	1.00	351L10	10.0	1/8	.56	1.00					
251L11.5	11.5	1/8	.43	1.00	351L11.5	11.5	1/8	.56	1.00					
251L13	13.0	1/8	.43	1.00	351L13	13.0	1/8	.56	1.00					
1/4" PIPE EXTENSIONS														
252L2.5	2.5	1/4	.56	.87	352L2.5	2.5	1/4	.56	.87	AVAILABLE ON REQUEST				
252L4	4.0	1/4	.56	1.25	352L4	4.0	1/4	.56	1.25					
252L5.5	5.5	1/4	.56	1.25	352L5.5	5.5	1/4	.56	1.25					
252L7	7.0	1/4	.56	1.25	352L7	7.0	1/4	.56	1.25					
252L8.5	8.5	1/4	.56	1.25	352L8.5	8.5	1/4	.56	1.25					
252L10	10.0	1/4	.56	1.25	352L10	10.0	1/4	.56	1.25					
252L11.5	11.5	1/4	.56	1.25	352L11.5	11.5	1/4	.56	1.25					
252L13	13.0	1/4	.56	1.25	352L13	13.0	1/4	.56	1.25					
3/8" PIPE EXTENSIONS														
253L2.5	2.5	3/8	.68	1.00	353L2.5	2.5	3/8	.68	1.00	553L2.5	2.5	3/8	.81	1.12
253L4	4.0	3/8	.68	1.25	353L4	4.0	3/8	.68	1.25	553L4	4.0	3/8	.81	1.37
253L5.5	5.5	3/8	.68	1.25	353L5.5	5.5	3/8	.68	1.25	553L5.5	5.5	3/8	.81	1.37
253L7	7.0	3/8	.68	1.25	353L7	7.0	3/8	.68	1.25	553L7	7.0	3/8	.81	1.37
253L8.5	8.5	3/8	.68	1.25	353L8.5	8.5	3/8	.68	1.25	553L8.5	8.5	3/8	.81	1.37
253L10	10.0	3/8	.68	1.25	353L10	10.0	3/8	.68	1.25	553L10	10.0	3/8	.81	1.37
253L11.5	11.5	3/8	.68	1.25	353L11.5	11.5	3/8	.68	1.25	553L11.5	11.5	3/8	.81	1.37
253L13	13.0	3/8	.68	1.25	353L13	13.0	3/8	.68	1.25	553L13	13.0	3/8	.81	1.37
1/2" PIPE EXTENSIONS														
AVAILABLE ON REQUEST					354L2.5	2.5	1/2	.87	1.12	554L2.5	2.5	1/2	.87	1.12
					354L4	4.0	1/2	.87	1.50	554L4	4.0	1/2	.87	1.50
					354L5.5	5.5	1/2	.87	1.50	554L5.5	5.5	1/2	.87	1.50
					354L7	7.0	1/2	.87	1.50	554L7	7.0	1/2	.87	1.50
					354L8.5	8.5	1/2	.87	1.50	554L8.5	8.5	1/2	.87	1.50
					354L10	10.0	1/2	.87	1.50	554L10	10.0	1/2	.87	1.50
					354L11.5	11.5	1/2	.87	1.50	554L11.5	11.5	1/2	.87	1.50
					354L13	13.0	1/2	.87	1.50	554L13	13.0	1/2	.87	1.50



EXTENSION PLUGS KEYED CONNECT SERIES

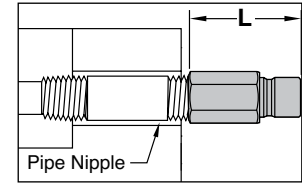
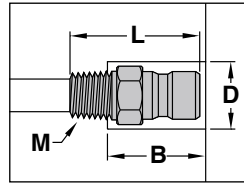


- Eliminate in/out connection mistakes, using the keyed plugs for all inlets
- Use with Keyed Socket Connectors shown on page E-27 only.
- Perfect for die cast jet cooling applications.

200 Series 1/4" HOLE					300 Series 3/8" HOLE					500 Series 1/2" HOLE				
CATALOG NUMBER	L LENGTH	M NPT	H HEX SIZE	A	CATALOG NUMBER	L LENGTH	M NPT	H HEX SIZE	A	CATALOG NUMBER	L LENGTH	M NPT	H HEX SIZE	A
1/16" PIPE EXTENSIONS (KEYED)														
250L2.5-K	2.5	1/16	.37	.68	350L2.5-K	2.5	1/16	.56	.87	AVAILABLE ON REQUEST				
250L4-K	4.0	1/16	.37	.81	350L4-K	4.0	1/16	.56	1.00					
250L5.5-K	5.5	1/16	.37	.81	350L5.5-K	5.5	1/16	.56	1.00					
250L7-K	7.0	1/16	.37	.81	350L7-K	7.0	1/16	.56	1.00					
1/8" PIPE EXTENSIONS (KEYED)														
251L2.5-K	2.5	1/8	.43	.68	351L2.5-K	2.5	1/8	.56	.87	AVAILABLE ON REQUEST				
251L4-K	4.0	1/8	.43	1.00	351L4-K	4.0	1/8	.56	1.00					
251L5.5-K	5.5	1/8	.43	1.00	351L5.5-K	5.5	1/8	.56	1.00					
251L7-K	7.0	1/8	.43	1.00	351L7-K	7.0	1/8	.56	1.00					
251L8.5-K	8.5	1/8	.43	1.00	351L8.5-K	8.5	1/8	.56	1.00					
251L10-K	10.0	1/8	.43	1.00	351L10-K	10.0	1/8	.56	1.00					
251L11.5-K	11.5	1/8	.43	1.00	351L11.5-K	11.5	1/8	.56	1.00					
251L13-K	13.0	1/8	.43	1.00	351L13-K	13.0	1/8	.56	1.00					
1/4" PIPE EXTENSIONS (KEYED)														
252L2.5-K	2.5	1/4	.56	.87	352L2.5-K	2.5	1/4	.56	.87	AVAILABLE ON REQUEST				
252L4-K	4.0	1/4	.56	1.25	352L4-K	4.0	1/4	.56	1.25					
252L5.5-K	5.5	1/4	.56	1.25	352L5.5-K	5.5	1/4	.56	1.25					
252L7-K	7.0	1/4	.56	1.25	352L7-K	7.0	1/4	.56	1.25					
252L8.5-K	8.5	1/4	.56	1.25	352L8.5-K	8.5	1/4	.56	1.25					
252L10-K	10.0	1/4	.56	1.25	352L10-K	10.0	1/4	.56	1.25					
252L11.5-K	11.5	1/4	.56	1.25	352L11.5-K	11.5	1/4	.56	1.25					
252L13-K	13.0	1/4	.56	1.25	352L13-K	13.0	1/4	.56	1.25					
3/8" PIPE EXTENSIONS (KEYED)														
253L2.5-K	2.5	3/8	.68	1.00	353L2.5-K	2.5	3/8	.68	1.00	553L2.5-K	2.5	3/8	.81	1.12
253L4-K	4.0	3/8	.68	1.25	353L4-K	4.0	3/8	.68	1.25	553L4-K	4.0	3/8	.81	1.37
253L5.5-K	5.5	3/8	.68	1.25	353L5.5-K	5.5	3/8	.68	1.25	553L5.5-K	5.5	3/8	.81	1.37
253L7-K	7.0	3/8	.68	1.25	353L7-K	7.0	3/8	.68	1.25	553L7-K	7.0	3/8	.81	1.37
253L8.5-K	8.5	3/8	.68	1.25	353L8.5-K	8.5	3/8	.68	1.25	553L8.5-K	8.5	3/8	.81	1.37
253L10-K	10.0	3/8	.68	1.25	353L10-K	10.0	3/8	.68	1.25	553L10-K	10.0	3/8	.81	1.37
253L11.5-K	11.5	3/8	.68	1.25	353L11.5-K	11.5	3/8	.68	1.25	553L11.5-K	11.5	3/8	.81	1.37
253L13-K	13.0	3/8	.68	1.25	353L13-K	13.0	3/8	.68	1.25	553L13-K	13.0	3/8	.81	1.37
1/2" PIPE EXTENSIONS (KEYED)														
AVAILABLE ON REQUEST					354L2.5-K	2.5	1/2	.87	1.12	554L2.5-K	2.5	1/2	.87	1.12
					354L4-K	4.0	1/2	.87	1.50	554L4-K	4.0	1/2	.87	1.50
					354L5.5-K	5.5	1/2	.87	1.50	554L5.5-K	5.5	1/2	.87	1.50
					354L7-K	7.0	1/2	.87	1.50	554L7-K	7.0	1/2	.87	1.50
					354L8.5-K	8.5	1/2	.87	1.50	554L8.5-K	8.5	1/2	.87	1.50
					354L10-K	10.0	1/2	.87	1.50	554L10-K	10.0	1/2	.87	1.50
					354L11.5-K	11.5	1/2	.87	1.50	554L11.5-K	11.5	1/2	.87	1.50
					354L13-K	13.0	1/2	.87	1.50	554L13-K	13.0	1/2	.87	1.50

CONNECTOR PLUGS

STANDARD SERIES



Inch Standard

M Brass

M Brass

	MALE TYPE: INCH						FEMALE TYPE: INCH			
	CATALOG NUMBER	M NPT	INNER DIAMETER	D	B	L	CATALOG NUMBER	M NPT	INNER DIAMETER	L
200 SERIES (1/4" HOLE)	250	1/16	3/16	.75	.75	.94	250F	1/16	1/4	.75
	251	1/8	1/4	.87	.75	.94	251F	1/8	1/4	1.00
	252	1/4	1/4	1.00	.94	1.13	252F	1/4	1/4	1.25
	253	3/8	1/4	1.12	.94	1.19	253F	3/8	1/4	1.16
300 SERIES (3/8" HOLE)	351	1/8	1/4	1.00	1.00	1.20	351F	1/8	11/32	1.00
	352	1/4	3/8	1.00	1.09	1.34	352F	1/4	3/8	1.34
	353	3/8	3/8	1.12	1.13	1.38	353F	3/8	3/8	1.34
	354	1/2	3/8	1.50	1.25	1.59	354F	1/2	3/8	1.57
500 SERIES (1/2" HOLE)	552	1/4	3/8	1.37	1.37	1.62	552F	1/4	7/16	1.25
	553	3/8	1/2	1.37	1.37	1.62	553F	3/8	9/16	1.37
	554	1/2	5/8	1.50	1.50	1.75	554F	1/2	5/8	1.75
	556	3/4	5/8	1.75	1.56	1.90	556F	3/4	5/8	1.75

Note: Use with Standard Series Socket Connectors sold on opposite page only.

International Standard

M Brass

M Brass

	MALE TYPE: BSPT or METRIC							FEMALE TYPE: BSPT				
	CATALOG NUMBER	M BSPT	INNER DIAMETER	D	B	L	HEX INCH	CATALOG NUMBER	M BSPT	INNER DIAMETER	L	HEX INCH
200 SERIES (6.35MM HOLE)	251-BSPT	1/8	6.4	22	19	24	7/16	251F-BSPT	1/8	6	25	1/2
	252-BSPT	1/4	6.4	25	24	29	9/16	252F-BSPT	1/4	6	32	5/8
	252-M10	M10	6.4	25	24	29	9/16					
300 SERIES (9.52MM HOLE)	351-BSPT	1/8	9.5	25	25	30	9/16	351F-BSPT	1/8	9	25	9/16
	352-BSPT	1/4	9.5	25	28	34	9/16	352F-BSPT	1/4	9	34	9/16
	353-BSPT	3/8	9.5	28	29	35	11/16	353F-BSPT	3/8	9	34	3/4
500 SERIES (12.7MM HOLE)	553-BSPT	3/8	12.7	35	35	41	13/16	553F-BSPT	3/8	15	35	13/16
	554-BSPT	1/2	15.8	38	38	44	7/8	554F-BSPT	1/2	15	44	1/2

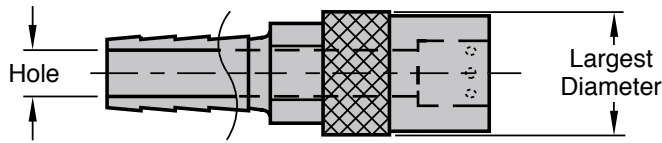
Note: Use with Metric or Inch threaded Standard Series Socket Connectors sold on opposite page only. Also, each BSPT connector is marked with an identification ring near the hex.

ALTERNATIVE CONFIGURATIONS AVAILABLE

- For Connector Plugs manufactured from stainless steel, add "-SS" to the end of the catalog number. Ex. 250-SS or 351-SS or 251-FSS
Note: 552F, 556F, and 252-M10 are available in brass only.



SOCKET CONNECTORS STANDARD SERIES



- Pressure to 200 psi
- Max temp = 400°F
- Use with standard Connector Plugs sold on opposite page or Extension Plugs sold on page E-22.

M Brass with Stainless Steel Bearings and Silicone Seals

		200 SERIES (1/4" HOLE)			300 SERIES (3/8" HOLE)			500 SERIES (1/2" Hole)		
		CATALOG NUMBER	HOSE ID	LARGEST DIA.	CATALOG NUMBER	HOSE ID	LARGEST DIA.	CATALOG NUMBER	HOSE ID	LARGEST DIA.
STRAIGHT		SC204	1/4	.71	SC306	3/8	.97	SC504	1/2	1.21
		SC205	5/16	.71	SC308	1/2	.97	SC506	3/4	1.21
		SC206	3/8	.71	-	-	-	-	-	-
90° STEM		SC214	1/4	.71	SC316	3/8	.97	SC514	1/2	1.21
		SC215	5/16	.71	SC318	1/2	.97	SC516	3/4	1.21
		SC216	3/8	.71	-	-	-	-	-	-
45° STEM		SC224	1/4	.71	SC326	3/8	.97	SC524	1/2	1.21
		SC225	5/16	.71	SC328	1/2	.97	SC526	3/4	1.21
		SC226	3/8	.71	-	-	-	-	-	-
Socket Body Only		CATALOG NUMBER	THREAD		CATALOG NUMBER	THREAD		CATALOG NUMBER	THREAD	
Straight		SC200B	1/8		SC300B	1/4		SC500B	1/2	
90° Degree		SC200B-4	1/4		SC300B-4	3/8		-	-	
		SC200B-90	1/4		SC300B-90	3/8		SC500B-90	1/2	
Replacement Seals: Silicone (Red)		SC200S			SC300S			SC500S		
Replacement Seals: Viton (Black)		SC200S-V			SC300S-V			SC500S-V		

ALTERNATIVE CONFIGURATIONS AVAILABLE

- To order valved style Socket Connectors or Bodies (shown at right), add "-V" to the end of the catalog number. Ex. SC316-V
- To order Socket Connectors or Bodies with barbs for Push-Lok® hose, specify "-PL" at the end of the catalog number. Ex. SC326-PL or SC306-V-PL
- Note: Valved versions (-V or -V-PL) are not available in the 500 series.



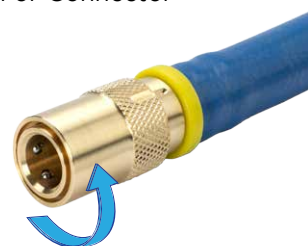
STANDARD SERIES: LOCKING CONNECTORS

This system provides a positive locking connection to Extension or Connector Plugs. Connect and twist to lock the sleeve into place.



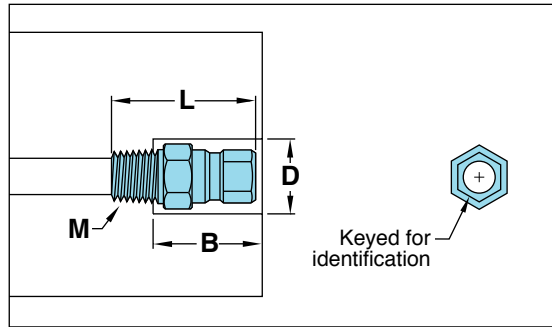
To Order:

- Specify "-L" as the suffix to the standard items in the chart above. Examples:
 SC205-L (Standard Barbs)
 SC300B-L (Body)
 SC326-PL-L (Push-Lok Barbs)
 Note: Not available in the Valved versions.



CONNECTOR PLUGS

KEYED CONNECT SERIES



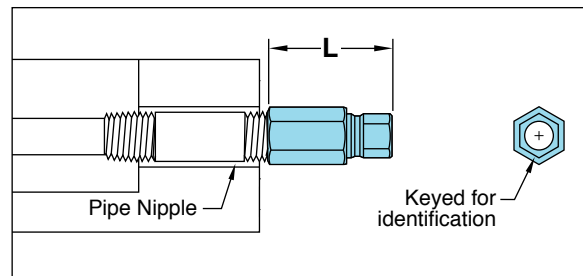
APPLICATION GUIDELINES

- Eliminate in/out connection mistakes, using the keyed plugs for all inlets.
- Enables faster changeover.
- Use with Keyed Socket Connectors as shown on opposite page only.

Male Type: Inch Standard

M Brass

200 SERIES (1/4" HOLE)						300 SERIES (3/8" HOLE)						500 SERIES (1/2" HOLE)					
CATALOG NUMBER	M NPT	INNER DIAMETER	D	B	L	CATALOG NUMBER	M NPT	INNER DIAMETER	D	B	L	CATALOG NUMBER	M NPT	INNER DIAMETER	D	B	L
250-K	1/16	3/16	.75	.75	.94	351-K	1/8	1/4	1.00	1.00	1.20	552-K	1/4	3/8	1.37	1.37	1.62
251-K	1/8	1/4	.87	.75	.94	352-K	1/4	3/8	1.00	1.09	1.34	553-K	3/8	1/2	1.37	1.37	1.62
252-K	1/4	1/4	1.00	.94	1.13	353-K	3/8	3/8	1.12	1.13	1.38	554-K	1/2	5/8	1.50	1.50	1.75
253-K	3/8	1/4	1.12	.94	1.19	354-K	1/2	3/8	1.50	1.25	1.59	556-K	3/4	5/8	1.75	1.56	1.90



Female Type: Inch Standard

M Brass

200 SERIES (1/4" HOLE)				300 SERIES (3/8" HOLE)				500 SERIES (1/2" HOLE)			
CATALOG NUMBER	M NPT	INNER DIAMETER	L	CATALOG NUMBER	M NPT	INNER DIAMETER	L	CATALOG NUMBER	M NPT	INNER DIAMETER	L
250F-K	1/16	1/4	1.00	351F-K	1/8	11/32	1.00	552F-K	1/4	7/16	1.25
251F-K	1/8	1/4	1.00	352F-K	1/4	3/8	1.00	553F-K	3/8	9/16	1.37
252F-K	1/4	1/4	1.25	353F-K	3/8	3/8	1.62	554F-K	1/2	5/8	1.75
253F-K	3/8	1/4	1.38	354F-K	1/2	3/8	1.75	556F-K	3/4	5/8	1.75

ALTERNATIVE CONFIGURATIONS AVAILABLE

- For Connector Plugs manufactured from stainless steel, add "-SS" to the end of the catalog number. Ex. 250-K-SS or 351F-K-SS
Note: The 250F-K, 351F-K and all 500 Series Female Plugs are available in brass only.
- Contact Customer Service for metric options.
- Keyed connectors do not fit standard Socket connectors.

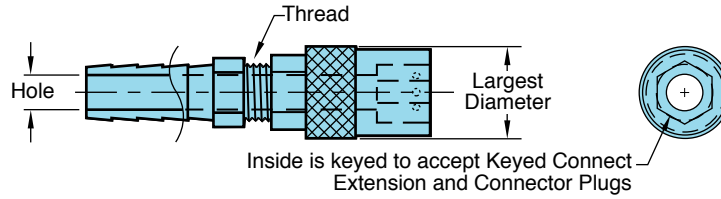


SOCKET CONNECTORS


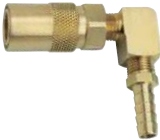


KEYED CONNECT SERIES

APPLICATION GUIDELINES

- Eliminate in/out connection mistakes, using the keyed plugs for all inlets
- Enables faster changeovers
- Pressure to 200 psi
- Max temp = 400°F
- Includes Blue Safety Clip
- Use with Keyed Connector Plugs sold on opposite page or Keyed Extension Plugs shown on page E-23.



M Brass with Stainless Steel Bearings and Silicone Seals

200 SERIES (1/4" HOLE)			300 SERIES (3/8" HOLE)			500 SERIES (1/2" HOLE)			
CATALOG NUMBER	HOSE ID	LARGEST DIA.	CATALOG NUMBER	HOSE ID	LARGEST DIA.	CATALOG NUMBER	HOSE ID	LARGEST DIA.	
STRAIGHT 	SC204-K	1/4	.71	SC306-K	3/8	.97	SC504-K	1/2	1.21
	SC205-K	5/16	.71	SC308-K	1/2	.97	SC506-K	3/4	1.21
	SC206-K	3/8	.71	-	-	-	-	-	-
90° STEM 	SC214-K	1/4	.71	SC316-K	3/8	.97	SC514-K	1/2	1.21
	SC215-K	5/16	.71	SC318-K	1/2	.97	SC516-K	3/4	1.21
	SC216-K	3/8	.71	-	-	-	-	-	-
45° STEM 	SC224-K	1/4	.71	SC326-K	3/8	.97	SC524-K	1/2	1.21
	SC225-K	5/16	.71	SC328-K	1/2	.97	SC526-K	3/4	1.21
	SC226-K	3/8	.71	-	-	-	-	-	-
Socket Body Only 	CATALOG NUMBER	THREAD		CATALOG NUMBER	THREAD		CATALOG NUMBER	THREAD	
	SC200B-K	1/8		SC300B-K	1/4		SC500B-K	1/2	
	SC200B-4-K	1/4		SC300B-4-K	3/8		-	-	
Replacement Seals: Silicone (Red)	SC200S			SC300S			SC500S		
Replacement Seals: Viton (Black)	SC200S-V			SC300S-V			SC500S-V		

Note: 200 and 300 Series Straight Socket Connectors are manufactured from a single piece, not assembled as shown.

ALTERNATIVE CONFIGURATIONS AVAILABLE

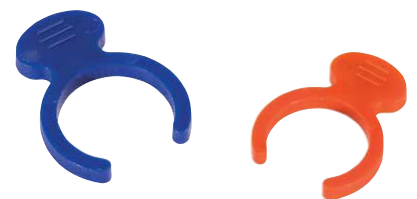
- To order Socket Connectors or Bodies with barbs for Push-Lok® hose, specify "-PL" before the -K within the catalog number. Ex. SC326-PL-K or SC306-PL-K

APPLICATION GUIDELINES

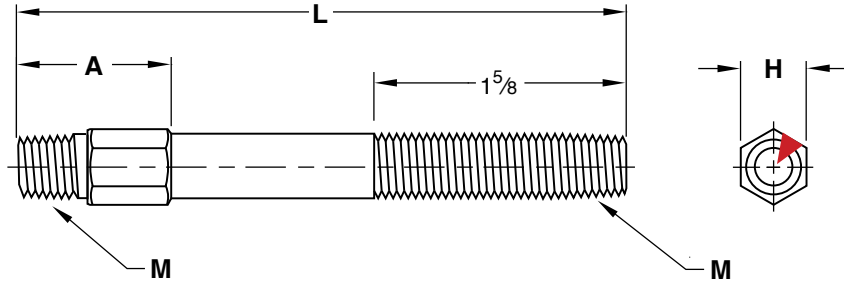
- Clips are designed for the Keyed Connect Series of Socket Connectors. They can be used on the standard or locking Socket Connectors but will be for color designation only.

CATALOG NUMBER	COLOR	SERIES
SC200-BL	Blue	200
SC300-BL		300
SC500-BL		500
SC200-R	Red	200
SC300-R		300
SC500-R		500

SAFETY CLIPS



ADJUSTABLE HEX NIPPLES



M Brass

CATALOG NUMBER	M PIPE NPT	A	H	AVAILABLE OVERALL LENGTHS (L)							
				2.5	4	5.5	7	8.5	10	11.5	13
APN06	1/16	.68	3/8	•	•	•	•	•	•	•	•
APN12	1/8	.75	7/16	•	•	•	•	•	•	•	•
APN25	1/4	.87	9/16	•	•	•	•	•	•	•	•
APN37	3/8	1.00	11/16	•	•	•	•	•	•	•	•
APN50	1/2	1.37	7/8	•	•	•	•	•	•	•	•

▶ CAD insertion point

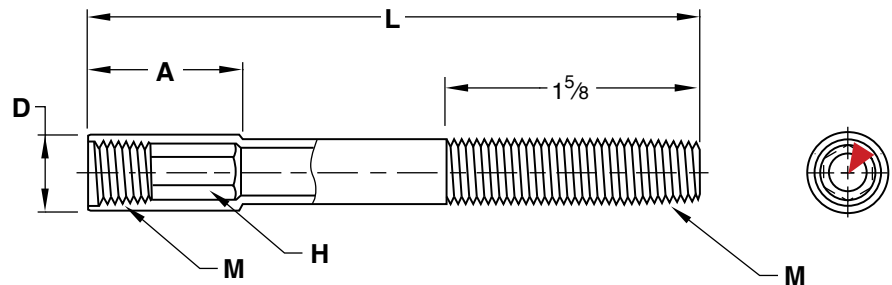
ALTERNATIVE CONFIGURATIONS AVAILABLE

To Order:

- Specify prefix and length. Ex APN50L11.5.

- For Adjustable Hex Nipples manufactured from stainless steel, add “-SS” to the end of the catalog number. Ex. APN25L7-SS or APN50L4-SS
- Adjustable Hex Nipples can be ordered cut to any length, in any quantity. Specify the catalog number (for brass or stainless steel) with required length. Ex. APN25L6.25 or APN37L5.75-SS

HEX KEY EXTENSION PIPES



M Brass

CATALOG NUMBER	M PIPE NPT	A	D	H	AVAILABLE OVERALL LENGTHS (L)				
					2.5	4	5.5	7	8.5
HKEPN12	1/8	.75	.50	1/4	•	•	•	•	•
HKEPN25	1/4	1.00	.69	3/8	•	•	•	•	•
HKEPN37	3/8	1.25	.81	1/2	•	•	•	•	•
HKEPN50	1/2	1.50	1.00	9/16	•	•	•	•	•

▶ CAD insertion point

To Order:

- Specify prefix and length. Ex. HKEPN12L2.5

ALTERNATIVE CONFIGURATIONS AVAILABLE

- Hex Key Extension Pipes can be ordered cut to any length in any quantity. Specify the catalog prefix with required length. Ex. HKEPN25L6.25

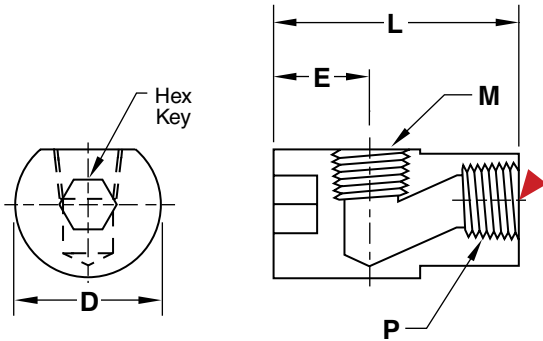


HEX KEY ELBOWS



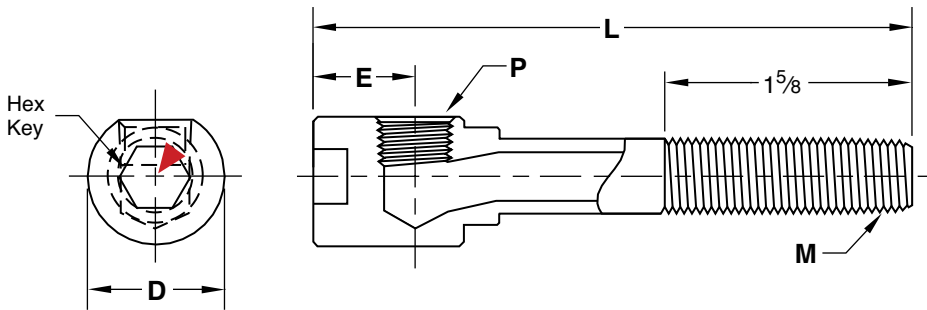
M Brass

▶ CAD insertion point



CATALOG NUMBER	M NPT	P NPT	HEX KEY	L	D	E
HK1616	1/16	1/16	1/4	1.12	.552	.531
HK1818	1/8	1/8	5/16	1.25	.615	.580
HK1814	1/8	1/4	3/8	1.375	.860	.593
HK1414	1/4	1/4	3/8	1.50	.860	.660
HK3838	3/8	3/8	1/2	1.75	.985	.780
HK1438	1/4	3/8	1/2	1.625	.985	.712
HK1212	1/2	1/2	1/2	2.12	1.235	.940

HEX KEY EXTENSION ELBOWS



M Brass

▶ CAD insertion point

To Order:

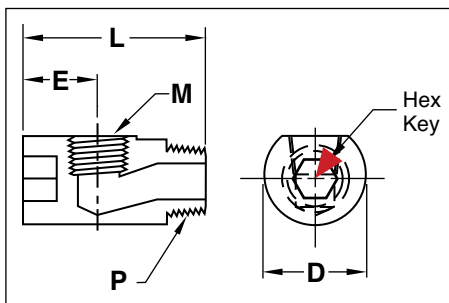
- Specify Prefix and length.
Ex. HKEE1818L2.5 or HKEE1414L11.5
- Hex Key Extension Elbows can be ordered in any length in any quantity. Specify the catalog prefix with the required length.
Ex. HKEE1414L3.75

CATALOG NUMBER	M PIPE NPT	P NPT	HEX KEY	D	E	Available Overall Lengths (L)								
						2.5	4	5.5	7	8.5	10	11.5	13	
HKEE1616	1/16	1/16	1/4	.552	.531	•	•	•	•	•	•	•	•	•
HKEE1818	1/8	1/8	5/16	.615	.580	•	•	•	•	•	•	•	•	•
HKEE1414	1/4	1/4	3/8	.860	.660	•	•	•	•	•	•	•	•	•
HKEE3838	3/8	3/8	1/2	.985	.780	•	•	•	•	•	•	•	•	•
HKEE1212	1/2	1/2	1/2	1.235	.940	•	•	•	•	•	•	•	•	•

HEX KEY STREET ELBOWS

M Brass

▶ CAD insertion point



CATALOG NUMBER	M NPT	P NPT	HEX KEY	L	D	E
HKL1616	1/16	1/16	1/4	1.156	.552	.531
HKL1618	1/16	1/8	5/16	1.218	.615	.531
HKL1818	1/8	1/8	5/16	1.312	.615	.580
HKL1814	1/8	1/4	3/8	1.500	.860	.593
HKL1414	1/4	1/4	3/8	1.625	.860	.660
HKL1438	1/4	3/8	1/2	1.625	.985	.712
HKL3838	3/8	3/8	1/2	1.750	.985	.780
HKL1212	1/2	1/2	1/2	2.250	1.235	.940



PIPE NIPPLES



M Brass or Stainless Steel

BRASS CATALOG NUMBER	STAINLESS CATALOG NUMBER	PIPE SIZE NPT	CLOSE OVERALL LENGTH	AVAILABLE OVERALL LENGTHS (L)																	
				Close*	1	1.5	2	2.5	3	3.5	4	4.5	5	5.5	6	7	8	9	10	11	12
BPN06	GPN06	1/16	5/8	•	•	•	•	•	•	•	•	•	•	•	•	•	•	•	•	•	•
BPN12	GPN12	1/8	3/4	•		•	•	•	•	•	•	•	•	•	•	•	•	•	•	•	•
BPN25	GPN25	1/4	7/8	•		•	•	•	•	•	•	•	•	•	•	•	•	•	•	•	•
BPN37	GPN37	3/8	1	•		•	•	•	•	•	•	•	•	•	•	•	•	•	•	•	•
BPN50	GPN50	1/2	1-1/8	•		•	•	•	•	•	•	•	•	•	•	•	•	•	•	•	•

*Close is the shortest available nipple length.

To Order:

- Specify prefix and length. Ex. BPN37CLOSE or BPN12L3.5
- Pipe Nipples can be ordered cut to any length, in any quantity. To order, specify the prefix and required length. Ex. BPN37L5.25 or GPN12L2.25

PUSH-LOK® HOSE



M Synthetic Rubber Tube (Parker Series 801)

CATALOG NUMBER	HOSE I.D.	HOSE O.D.	MINIMUM BEND RADIUS (IN)	INCHES OF MERCURY
WJH25-	1/4	.50	2.5	28
WJH31-BA	5/16	.58	3	28
WJH37-	3/8	.63	3	28
WJH50-	1/2	.78	5	28
WJH62-	5/8	.91	6	15
WJH75-	3/4	1.03	7	15

APPLICATION GUIDELINES

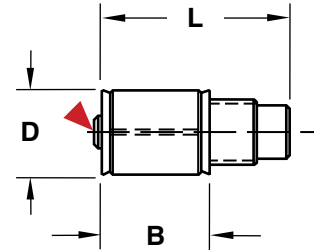
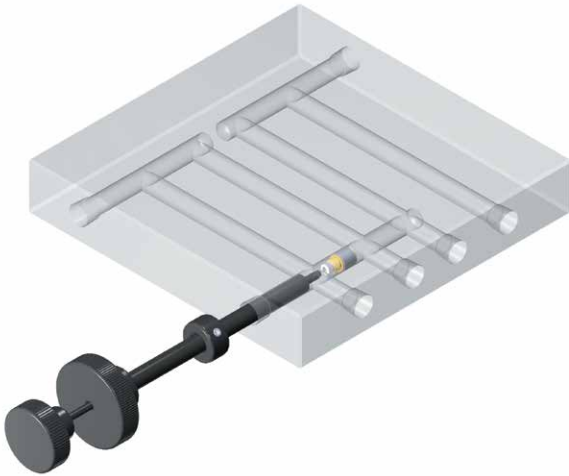
- Sold in 24" lengths.
- Max temperature with water: 190°F (90°C).
- Working pressure: 250 psi
- Burst pressure: 1000 psi
- Note: WJH31 is only available in Black (BA).

To Order:

- Specify catalog number with the appropriate color suffix: Gray (GR), Black (BA), Blue (BL), Green (G), Yellow (Y), and Red (R). Ex. WJH50-Y.
- For a 50' box, specify "-B" after the color. Ex. WJH37-Y-B.
- Reels also available by contacting Customer Service.



WATER BLOCKER™ PLUGS



APPLICATION GUIDELINES

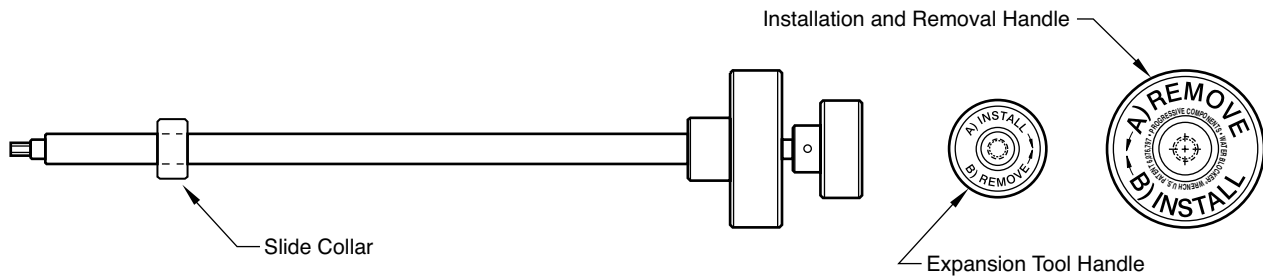
- Water Blocker Plugs are used to divert the flow of water, and can be removed and reinstalled for maintenance purposes.
- Maximum Pressure: 175 PSI
- Wrench (sold below) is available in two different lengths on most sizes.

M Brass with Stainless Steel Screw

CATALOG NUMBER	D ±.005	B	L	WATERLINE NOMINAL	WATERLINE DIAMETER
WB250	.245	.36	.60	1/16 NPT	.250
WB344	.334	.41	.71	1/8 NPT	.344
WB344-75	.334	.79	1.094	1/8 NPT	.344
WB375	.365	.41	.71	1/4 NPT	.375
WB437	.428	.43	.78	1/4 NPT	.437
WB562	.552	.57	.92	3/8 NPT	.562
WB688	.678	.64	1.06	1/2 NPT	.688

▶ CAD insertion point

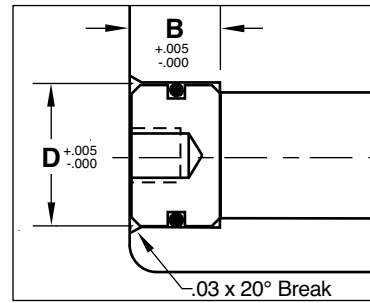
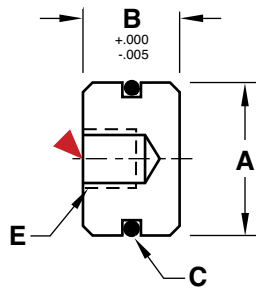
WRENCHES



CATALOG NUMBER	WATER BLOCKER	OVERALL LENGTH
WB25S24	WB250	24"
WBS12	WB344-WB375	12"
WBS24	WB344-WB375	24"
WBL12	WB437-WB688	12"
WBL24	WB437-WB688	24"

THREADLESS PLUGS

PUSH-IN O-RING PLUGS



Threadless O-Ring Plugs are designed for inserts backed up by mold steel.

M Brass with Buna O-Rings

Maximum temp: 250°F (120°C)

CATALOG NUMBER	A	B	C O-RING	D REAM DIA.	E	REPLACEMENT O-RING (BUNA)
TWP281	.273	.250	1/16	.281	#6-32	OR-007
TWP375	.366	.312	1/16	.375	#10-32	OR-010
TWP500	.494	.312	1/16	.500	#10-32	OR-012
TWP625	.618	.437	3/32	.625	1/4-20	OR-111
TWP750	.743	.500	3/32	.750	1/4-20	OR-113
TWP1000	.990	.625	1/8	1.000	3/8-16	OR-117
TWP1187	1.177	.625	1/8	1.187	3/8-16	OR-120

ALTERNATIVE CONFIGURATIONS AVAILABLE

- For plugs with Viton O-rings (maximum temperature 400°F, 200°C) specify “-V” at the end of the catalog number. Ex. TWP500-V or OR-007-V for the O-ring.
- For stainless steel threadless plugs, specify “-SS” at the end of the catalog number. Ex. TWP500-SS or TWP281-SS-V for stainless plugs with Viton O-rings.

▶ CAD insertion point

TAP-IN O-RING PLUGS

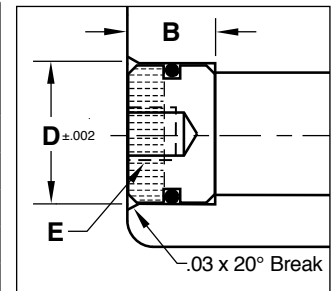
M Brass with Viton O-Rings



APPLICATION GUIDELINES

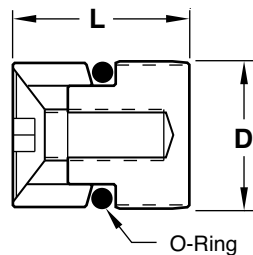
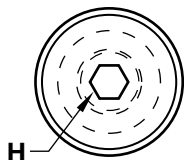
- Tap-In O-Ring Plugs do not require steel back up.
- Viton O-Rings included for maximum temperature of 400°F (200°C).
- Max pressure: 200 psi

CATALOG NUMBER	NOMINAL PIPE SIZE	D REAM DIA.	B DEPTH +.005 / -.000	E
TAP281	1/16	.281	.312	#6-32
TAP375	1/8	.375	.312	#10-32
TAP500	1/4	.500	.375	1/4-20
TAP625	3/8	.625	.437	5/16-18
TAP750	1/2	.750	.500	5/16-18



THREADLESS DIVERTING PLUGS

M Brass with Buna O-Rings



CATALOG NUMBER	NOMINAL PIPE SIZE	D DRILL SIZE	H	L
TDP12	1/8	11/32	5/64	.50
TDP12-OS	1/8	23/64	5/64	.50
TDP25	1/4	7/16	1/8	.56
TDP25-OS	1/4	29/64	1/8	.56
TDP37	3/8	9/16	1/8	.62
TDP37-OS	3/8	37/64	1/8	.62
TDP50	1/2	11/16	1/8	.62
TDP50-OS	1/2	45/64	1/8	.62

APPLICATION GUIDELINES

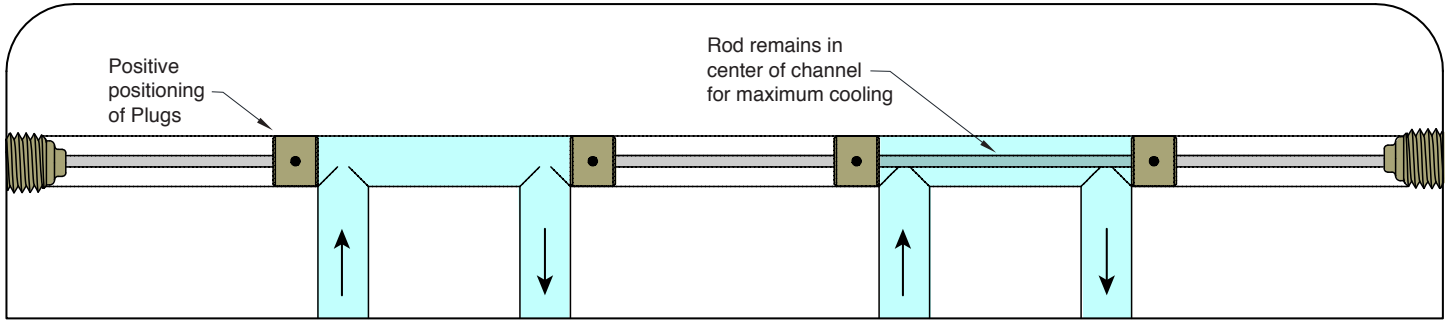
- Maximum pressure: 70 psi

ALTERNATIVE CONFIGURATIONS AVAILABLE

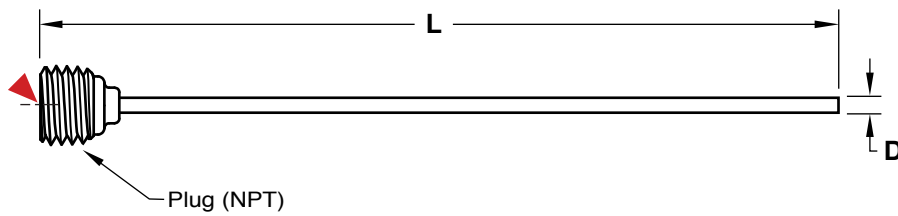
- For plugs with Viton O-rings (maximum temperature 400°F, 200°C) specify “-V” at the end of the catalog number. Ex. TDP50-V or TDP50-OS-V



DIVERTING RODS & PLUGS



RODS



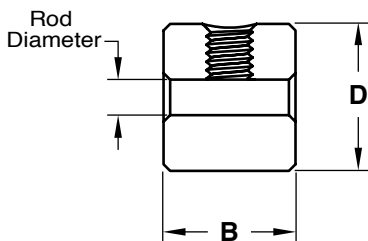
M Brass with Stainless Steel Rod

CATALOG NUMBER	PIPE SIZE NPT	L	D	DIVERTER PLUGS USED
DR125	1/8	12	3/32	D125
DR250	1/4	18	1/8	D250
DR375	3/8	18	1/8	D375
DR500	1/2	24	3/16	D500
DR750	3/4	24	3/16	D750
DR1000	1	36	3/16	D1000

▶ CAD insertion point

ALTERNATIVE CONFIGURATIONS AVAILABLE

- Longer lengths and Diverter Rods cut to length are available. Contact Customer Service for pricing and delivery.



PLUGS

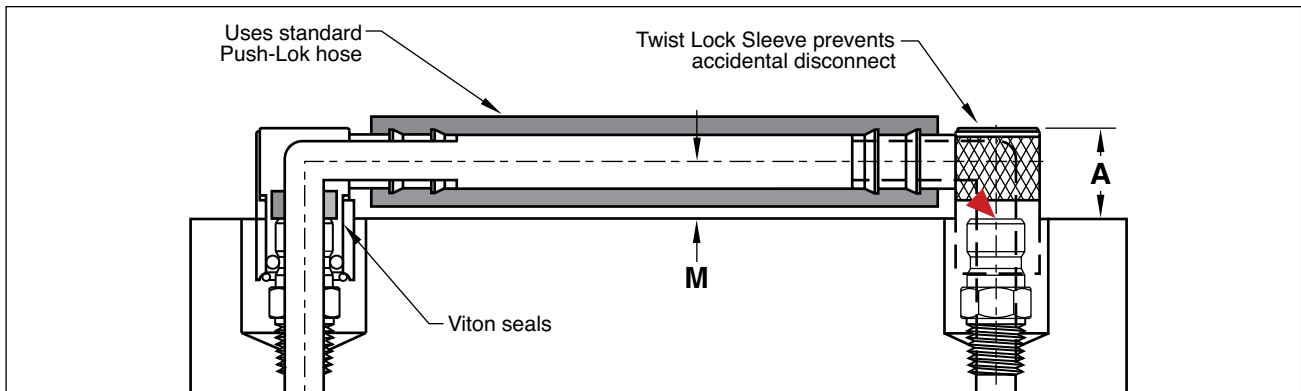
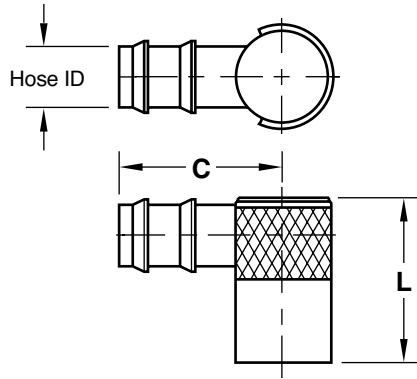
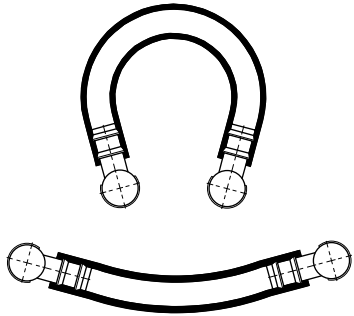


CATALOG NUMBER	FOR PIPE SIZE NPT	FOR ROD DIAMETER	D +.000 -.005	B
D125	1/8	3/32	.340	3/8
D250	1/4	1/8	.432	7/16
D375	3/8	1/8	.557	1/2
D500	1/2	3/16	.682	3/4
D750	3/4	3/16	.932	3/4
D1000	1	3/16	1.115	3/4

Includes locking screw.

WATER JUMPERS

PUSH-LOK® SERIES



▶ CAD insertion point

M Brass and Stainless Steel

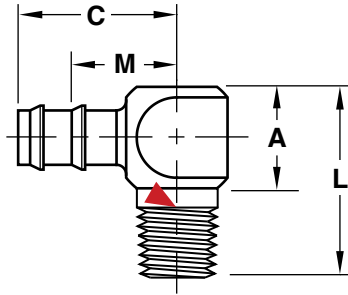
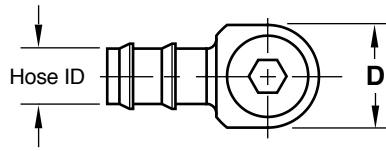
CATALOG NUMBER	FITS PLUG SERIES NUMBER	HOSE I.D.	L	C	M	A
WJ200-25	200	1/4	1	1-1/4	3/8	5/8
WJ200-37	200	3/8	1	1-1/4	3/8	5/8
WJ300-37	300	3/8	1-7/16	1-9/16	1/2	7/8
WJ300-50	300	1/2	1-7/16	1-9/16	1/2	7/8
WJ500-50	500	1/2	2-1/8	1-7/8	7/8	1-3/8
WJ500-75	500	3/4	2-1/8	2	7/8	1-3/8

APPLICATION GUIDELINES

- Maximum temp: 400°F (200°C)



WATER JUMPERS SWIVEL TYPE



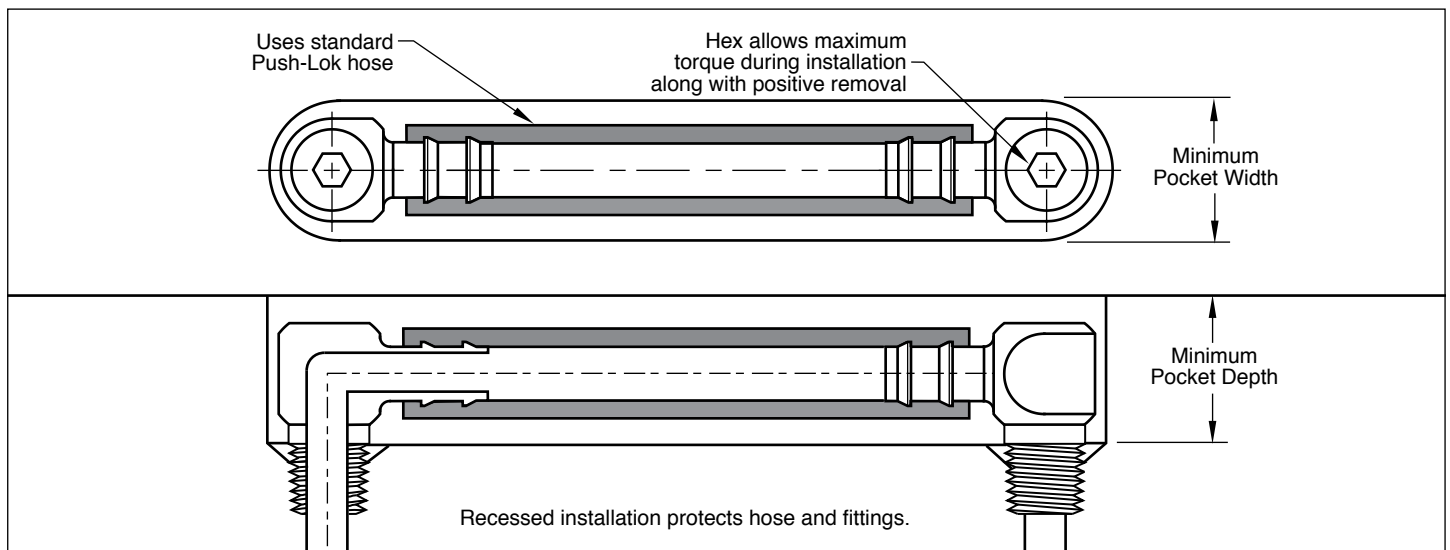
APPLICATION GUIDELINES

- Maximum temp: 400°F (200°C)

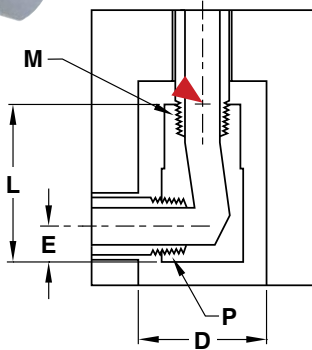
M Brass with internal Viton seals

CATALOG NUMBER	PIPE SIZE NPT	HOSE I.D.	HEX KEY SIZE	L	A	C	M	D	MIN. POCKET WIDTH	MIN. POCKET DEPTH
WJ125L1.1	1/8	5/16	3/16	1-3/16	11/16	1	5/8	.660	11/16	1
WJ125L2.0	1/8	5/16	3/16	2	11/16	1	5/8	.660	11/16	1
WJ125L3.5	1/8	5/16	3/16	3-1/2	11/16	1	5/8	.660	11/16	1
WJ250L1.4	1/4	3/8	1/4	1-7/16	13/16	1-3/16	25/32	.840	7/8	1-3/16
WJ250L2.3	1/4	3/8	1/4	2-3/8	13/16	1-3/16	25/32	.840	7/8	1-3/16
WJ250L3.8	1/4	3/8	1/4	3-7/8	13/16	1-3/16	25/32	.840	7/8	1-3/16
WJ375L1.6	3/8	1/2	5/16	1-5/8	1	1-3/8	15/16	.980	1	1-3/8
WJ375L2.6	3/8	1/2	5/16	2-5/8	1	1-3/8	15/16	.980	1	1-3/8
WJ375L4.1	3/8	1/2	5/16	4-1/8	1	1-3/8	15/16	.980	1	1-3/8
WJ500L2.0	1/2	3/4	3/8	2	1-1/8	1-1/2	1-1/8	1.235	1-1/4	1-9/16
WJ500L2.0-50	1/2	1/2	3/8	2	1-1/8	1-1/2	1-1/8	1.235	1-1/4	1-9/16
WJ500L3.0	1/2	3/4	3/8	3	1-1/8	1-1/2	1-1/8	1.235	1-1/4	1-9/16
WJ500L3.0-50	1/2	1/2	3/8	3	1-1/8	1-1/2	1-1/8	1.235	1-1/4	1-9/16
WJ500L4.5	1/2	3/4	3/8	4-1/2	1-1/8	1-1/2	1-1/8	1.235	1-1/4	1-9/16
WJ500L4.5-50	1/2	1/2	3/8	4-1/2	1-1/8	1-1/2	1-1/8	1.235	1-1/4	1-9/16

▶ CAD insertion point



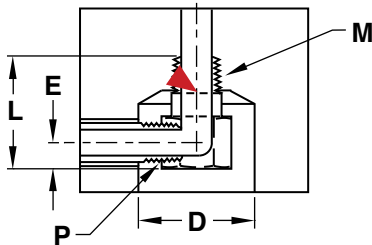
HEX ELBOWS FEMALE



▶ CAD insertion point

ALLOY STEEL CATALOG NUMBER	BRASS CATALOG NUMBER	M NPT	P NPT	HEX SIZE	L	D	E
HEL1616	HELB1616	1/16	1/16	9/16	.81	1.00	.218
HEL1818	HELB1818	1/8	1/8	3/4	1.00	1.25	.281
HEL1414	HELB1414	1/4	1/4	7/8	1.37	1.37	.343
HEL3838	HELB3838	3/8	3/8	1	1.62	1.50	.500
HEL1212	HELB1212	1/2	1/2	1-1/4	1.87	1.87	.562
HEL3434	HELB3434	3/4	3/4	1-1/2	2.25	2.25	.625

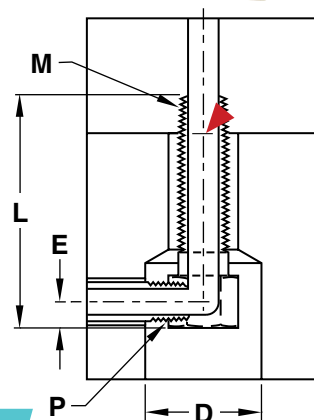
MALE



▶ CAD insertion point

ALLOY STEEL CATALOG NUMBER	BRASS CATALOG NUMBER	M NPT	P NPT	HEX SIZE	L	D	E
HEL1616M	HELB1616M	1/16	1/16	9/16	.81	1.00	.218
HEL1818M	HELB1818M	1/8	1/8	3/4	1.06	1.25	.281
HEL1814M	HELB1814M	1/4	1/8	3/4	1.06	1.25	.281
HEL1414M	HELB1414M	1/4	1/4	7/8	1.31	1.37	.343
HEL1438M	HELB1438M	3/8	1/4	7/8	1.31	1.37	.343
HEL3838M	HELB3838M	3/8	3/8	1	1.62	1.50	.437
HEL1212M	HELB1212M	1/2	1/2	1-1/4	2.00	1.87	.562
HEL7575M	HELB7575M	3/4	3/4	1-1/2	2.12	2.25	.625

EXTENSION ELBOWS MALE



M Brass

▶ CAD insertion point

CATALOG NUMBER	M PIPE NPT	P IN/OUT NPT	HEX SIZE	D	E	AVAILABLE OVERALL LENGTHS (L)							
						2.5	4	5.5	7	8.5	10	11.5	13
HELB1818	1/8	1/8	.75	1.25	.28	•	•	•	•	•	•	•	•
HELB1814	1/4	1/8	.75	1.25	.28	•	•	•	•	•	•	•	•
HELB1414	1/4	1/4	.87	1.37	.34	•	•	•	•	•	•	•	•
HELB1438	3/8	1/4	.875	1.37	.34	•	•	•	•	•	•	•	•
HELB3838	3/8	3/8	1.00	1.50	.50	•	•	•	•	•	•	•	•
HELB1212	1/2	1/2	1.25	1.75	.62	•	•	•	•	•	•	•	•

To Order:

- Specify prefix and length. Ex. HELB1818L2.5 or HELB1414L11.5

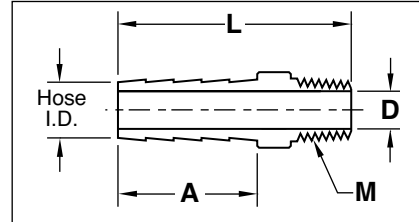


FITTINGS

MALE HOSE BARBS

M Brass

CATALOG NUMBER	M NPT	HOSE I.D.	D	A	L
MB16-0	#10-32 UNF	1/16	.052	.45	.57
MB18-0	#10-32 UNF	1/8	.090	.56	.81
MB18-2	1/8	1/8	.093	.50	1.03
MB14-2	1/8	1/4	.187	.97	1.54
MB14-4	1/4	1/4	.187	.97	1.64
MB15-2	1/8	5/16	.250	.97	1.54
MB15-4	1/4	5/16	.250	.97	1.64
MB38-2	1/8	3/8	.281	.97	1.54
MB38-4	1/4	3/8	.281	.97	1.64
MB50-4	1/4	1/2	.375	.97	1.64
MB50-6	3/8	1/2	.375	.97	1.76
MB50-8	1/2	1/2	.375	.97	1.86
MB75-8	1/2	3/4	.562	.97	1.86
MB75-12	3/4	3/4	.562	.97	1.97

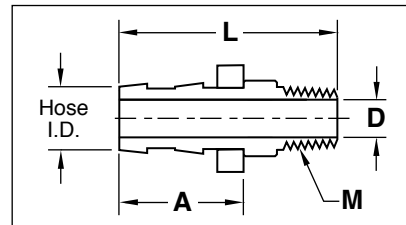


Note: MB16 and MB18 include Buna O-rings and clamps.

M Brass

CATALOG NUMBER	M NPT	HOSE I.D.	D	A	L
MB14-1-PL	1/16	1/4	.187	.97	1.69
MB14-2-PL	1/8	1/4	.187	.97	1.54
MB14-4-PL	1/4	1/4	.187	.97	1.64
MB38-2-PL	1/8	3/8	.281	.97	1.54
MB38-4-PL	1/4	3/8	.281	.97	1.64
MB38-6-PL	3/8	3/8	.281	.97	1.75
MB38-8-PL	1/2	3/8	.281	.97	1.97
MB50-4-PL	1/4	1/2	.375	.97	1.64
MB50-6-PL	3/8	1/2	.375	.97	1.76
MB50-8-PL	1/2	1/2	.375	.97	1.86
MB50-12-PL	3/4	1/2	.375	.97	1.97
MB75-8-PL	1/2	3/4	.562	.97	1.86
MB75-12-PL	3/4	3/4	.562	.97	1.97

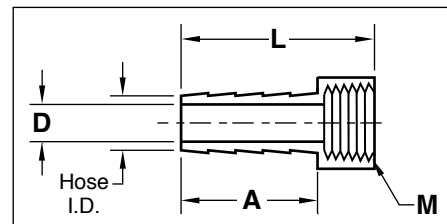
MALE PUSH-LOK HOSE BARBS



M Brass

CATALOG NUMBER	M NPT	HOSE I.D.	D	A	L
FB14-2	1/8	1/4	.187	.97	1.47
FB14-4	1/4	1/4	.187	.97	1.58
FB15-4	1/4	5/16	.250	.97	1.58
FB38-2	1/8	3/8	.281	.97	1.47
FB38-4	1/4	3/8	.281	.97	1.58
FB50-6	3/8	1/2	.375	.97	1.63
FB50-8	1/2	1/2	.375	.97	1.73

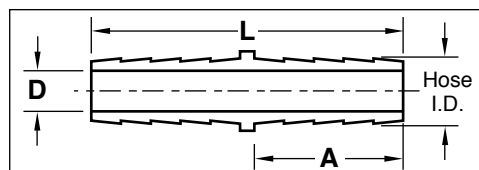
FEMALE HOSE BARBS



M Brass

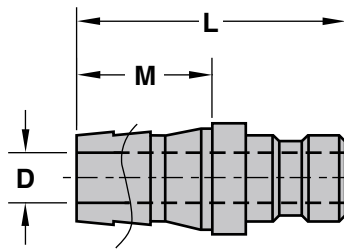
CATALOG NUMBER	HOSE I.D.	D	A	L
HS14	1/4	.187	.97	2.00
HS38	3/8	.281	.97	2.00
HS50	1/2	.375	.97	2.00

HOSE SPLICERS



COMBINATION HOSE INSERTS

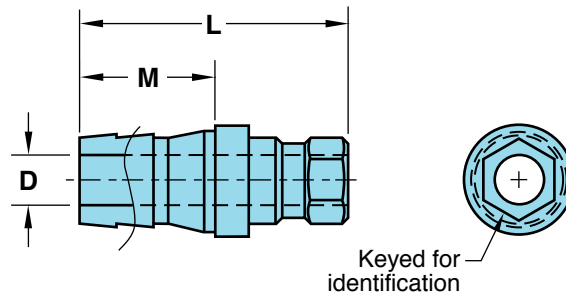
STANDARD SERIES



M Brass

200 SERIES (1/4" HOLE)					300 SERIES (3/8" HOLE)					500 SERIES (1/2" HOLE)				
CATALOG NUMBER	HOSE I.D.	D	M	L	CATALOG NUMBER	HOSE I.D.	D	M	L	CATALOG NUMBER	HOSE I.D.	D	M	L
200-4	1/4	3/16	.875	1.37	300-4	1/4	3/16	.875	1.81	500-8	1/2	13/32	1.062	2.00
200-5	5/16	1/4	.875	1.37	300-5	5/16	1/4	.875	1.81	500-12	3/4	9/16	1.500	2.50
200-6	3/8	1/4	1.062	1.56	300-6	3/8	9/32	1.062	1.81					
200-8	1/2	1/4	1.062	1.56	300-8	1/2	11/32	1.062	1.81					

KEYED CONNECT SERIES



M Brass

200 SERIES (1/4" HOLE)					300 SERIES (3/8" HOLE)					500 SERIES (1/2" HOLE)				
CATALOG NUMBER	HOSE I.D.	D	M	L	CATALOG NUMBER	HOSE I.D.	D	M	L	CATALOG NUMBER	HOSE I.D.	D	M	L
200-4-K	1/4	3/16	.875	1.37	300-6-K	3/8	9/32	1.062	1.81	500-8-K	1/2	13/32	1.062	2.00
200-6-K	3/8	1/4	1.062	1.56	300-8-K	1/2	11/32	1.062	1.81	500-12-K	3/4	9/16	1.500	2.50

Note: Keyed Combination Hose Inserts do not fit standard Socket Connectors.



COVER PLUGS

M Brass

CATALOG NUMBER	FITS SOCKET SERIES
CP200	200 (1/4")
CP300	300 (3/8")
CP500	500 (1/2")



CLAMPS

CATALOG NUMBER	HOSE O.D.
HC58	5/8
HC78	7/8
HC118	1-1/8



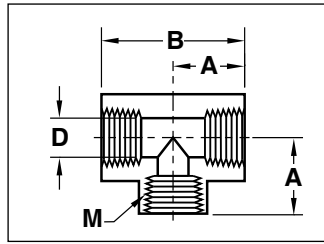
SEALANT TAPE

CATALOG NUMBER	DESCRIPTION
TT250	1/4" x 520"
TT500	1/2" x 520"



FITTINGS

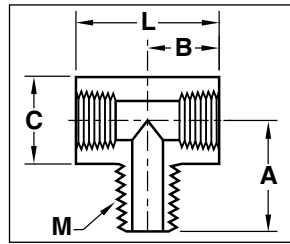
TEES



M Brass

CATALOG NUMBER	M NPT	A	B	D
T18	1/8	.55	1.10	.328
T14	1/4	.78	1.56	.422
T38	3/8	.87	1.68	.562
T50	1/2	1.07	2.14	.687

MALE TEES

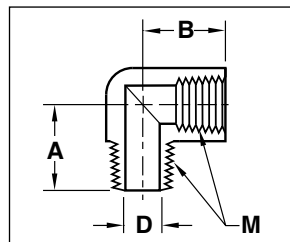


M Brass

CATALOG NUMBER	M NPT	A	B	C	L
MT10	#10-32 UNF	.500	.18	.38	.38
MT18	1/8	.66	.53	.56	1.06
MT14	1/4	.91	.76	.71	1.52
MT38	3/8	.97	.84	.81	1.68
MT50	1/2	1.26	1.09	1.00	2.18

Note: M10 includes O-ring.

90° STREET ELBOWS

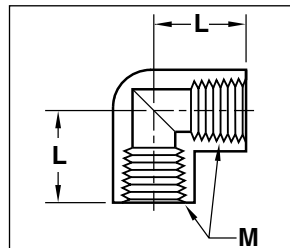


M Brass

CATALOG NUMBER	M NPT	A	B	D
ELS10	#10-32 UNF	.50	.18	.090
ELS18	1/8	.81	.56	.220
ELS14	1/4	.91	.45	.312
ELS38	3/8	.98	.54	.428
ELS50	1/2	1.25	1.03	.522

Note: ELS10 includes O-ring.

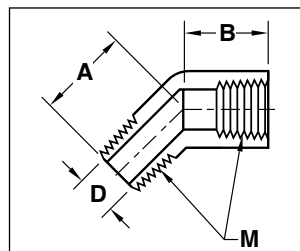
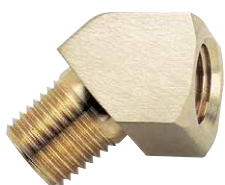
90° ELBOWS



M Brass

CATALOG NUMBER	M NPT	L
EL18	1/8	.55
EL14	1/4	.78
EL38	3/8	.84
EL50	1/2	1.09

45° STREET ELBOWS



M Brass

CATALOG NUMBER	M NPT	A	B	D
ELA18	1/8	.50	.38	.220
ELA14	1/4	.70	.54	.314
ELA38	3/8	.78	.54	.440
ELA50	1/2	1.00	.73	.562

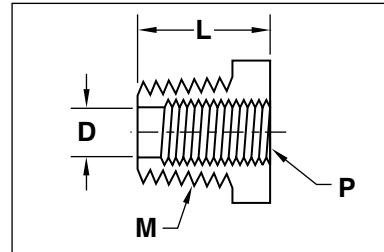


FITTINGS

REDUCING BUSHINGS

M Brass

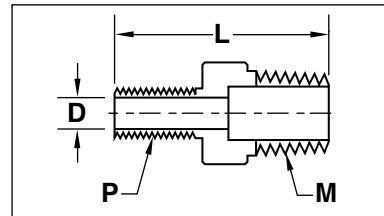
CATALOG NUMBER	M NPT	P NPT	L	D
RB18-0	1/8	#10-32 UNF	.56	.156
RB18-1	1/8	1/16	.56	.250
RB14-0	1/4	#10-32 UNF	.75	.156
RB14-2	1/4	1/8	.75	.328
RB38-4	3/8	1/4	.75	.422
RB50-6	1/2	3/8	1.00	.562



MALE REDUCERS

M Brass

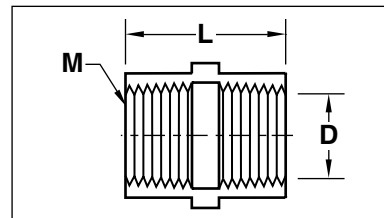
CATALOG NUMBER	M NPT	P NPT	L	D
MR18-1	1/8	1/16	1.19	.187
MR14-2	1/4	1/8	1.22	.220
MR38-4	3/8	1/4	1.41	.314
MR50-6	1/2	3/8	1.62	.440



COUPLINGS

M Brass

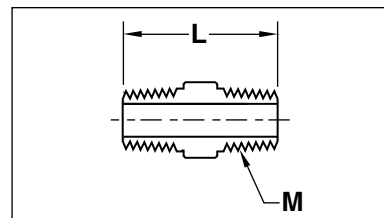
CATALOG NUMBER	M NPT	L	D
C18	1/8	.75	.328
C14	1/4	1.12	.422
C38	3/8	1.12	.562
C50	1/2	1.50	.688



HEX NIPPLES

M Brass

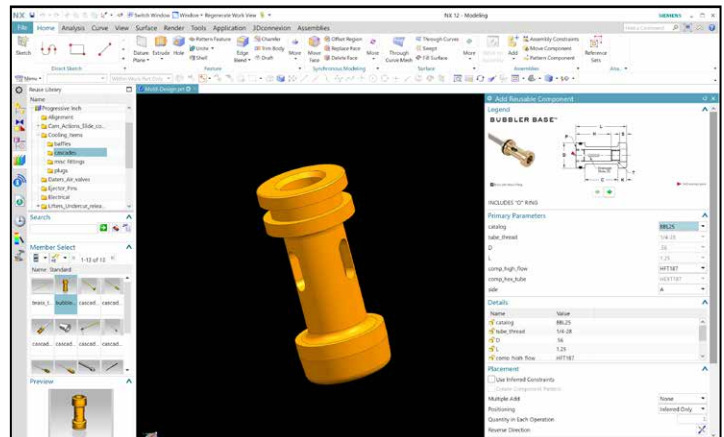
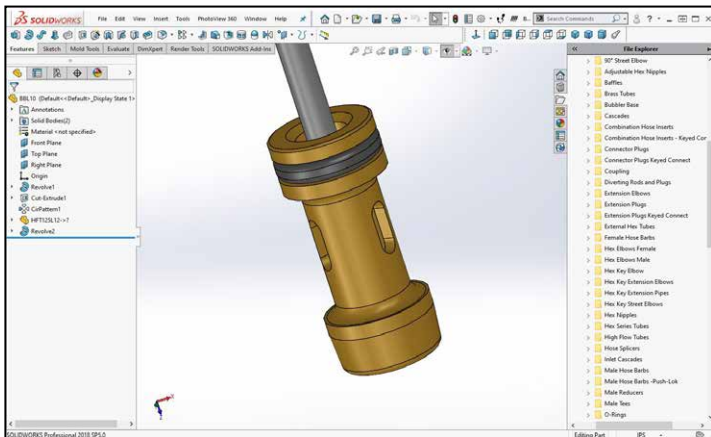
CATALOG NUMBER	M NPT	HEX SIZE	L
HN18	1/8	7/16	.969
HN14	1/4	9/16	1.375
HN38	3/8	11/16	1.437
HN50	1/2	7/8	1.813



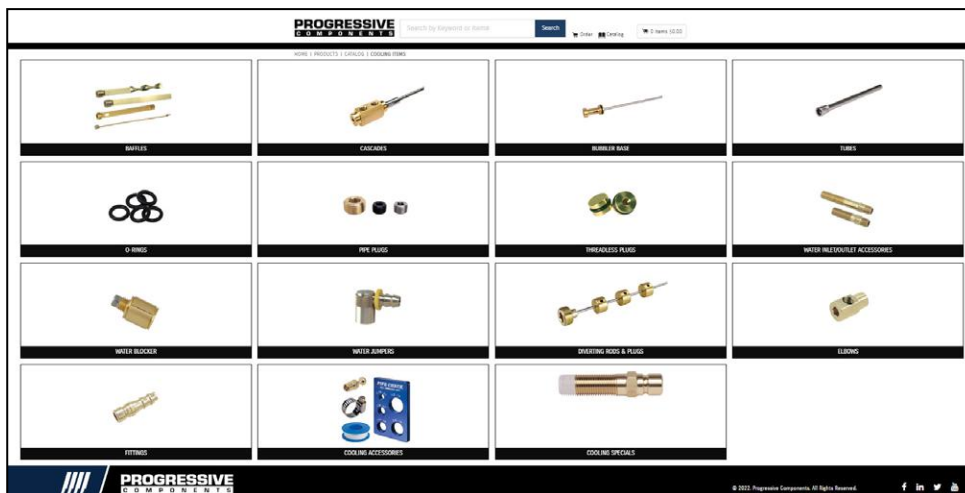
ONLINE RESOURCES



When considering design options, numerous animations can be viewed at procomps.com/animations.



CAD geometry is available online as individual downloads or as part of the CADalog system. The seven formats include: IGES (.igs), ACIS (.sat), STEP (.step), Parasolid (.x_t), SolidWorks (.sldasm), NX (.prt) (Re-Use and MoldWizard) and Visi (.wfk).



Industry-leading web store expedites the purchasing process. Go to shop.procomps.com for information and additional resources.



MOLD MONITORING

SECTION F



CVe Real-Time Monitor	ProFile: Real-Time	ProFile: Asset Management	Asset Tags & Plates
Prefix: CVE			Prefix: AMTG
Page: F-2	Page: F-3	Page: F-5	Page: F-6



CVe OnDemand Monitor	OnDemand Software	CounterView: S-Series	CounterView: R-Series
Prefix: CVE		Prefix: CVPL, CVIN, CVPLHT	Prefix: CVR-A, CVR-B
Page: F-7	Page: F-9	Page: F-10	Page: F-11



Insulator Blocks	CV/CVe Cover Plates	System Cooling	System Cooling Test Rig
Prefix: CV, CVMM, CVRA	Prefix: CV	Prefix: SCM	Prefix: SCTR
Page: F-12 & F-13	Page: F-12	Page: F-15	Page: F-18



PROFILE MAINTENANCE MANAGEMENT

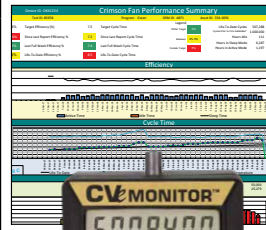
Asset Mgt.
Page F-6



CounterViews
Page F-10



CVe OnDemand
Page F-7



CVe Real-Time
Page F-2



QR Code for GPS Location	X			X
Asset Management	X	X	X	X
Preventive Maintenance, Work Order and Spare Parts Management	X		X	X
Real-Time Data				X
Cloud-Based File Sharing		X	X	X
Customizable Dashboards				X
APIs for Data Sharing With ERP/MES Systems				X
Multilingual options available	X		X	X
Requires PC-Based Software			X	
Collects Cycle Counts		X	X	X
Historical Data Reporting				X
Mobile App Compatible	X			X

1. Start with any platform based on your timeline, budget and/or resources. Contact SystemMonitoring@procomps.com to learn what platform is best for you and your customers.
2. Build and add additional systems at your own pace with various levels of visibility.
3. Progressive Components' Global Team will provide assistance and support from installation to production.

CVe MONITOR® RT

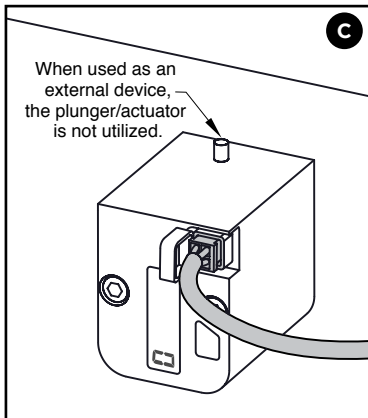
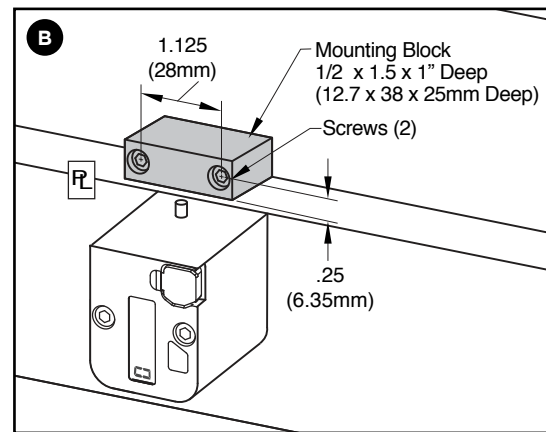
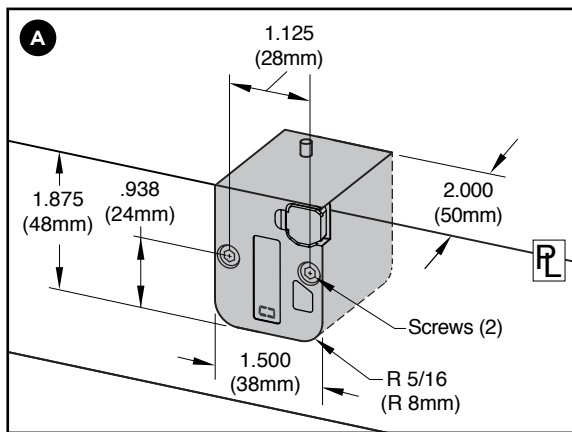
REAL-TIME MOLD MONITORING



APPLICATION GUIDELINES

- Progressive's Real-Time CVe Monitor tracks tool activity, allowing users to view the tool's cycle count on the display while also wirelessly sending data to the cloud.
- The QR code and unique serialization on every monitor aligns to a specific tool via the ProFile Real-Time Monitoring System (page F-3) and OnDemand App (page F-9).
- Includes two replaceable batteries.
- Display orientation can change on the device for either A side or B side installation. Water resistant with an ingress protection rating of IP52.
- Maximum temperature: 190°F (90°C).

MOUNTING OPTIONS



Parting Line Mount	A	Parting line mount makes unit visible to operator. Display orientation can be changed by pressing the button on the face.
External Mount	B	No pocket machining necessary. Designed specifically for retrofit applications. Order the CVe-RT and the CVe-EXT Block as shown below.
Non-Mold Use	C	The CVe Monitor can be wired to a PLC or other modules to act as a switch, not requiring any activation via an open/close event. See page F-4 for cable options.

CATALOG NUMBER	DESCRIPTION
CVe-RT	Real-Time CVe Monitor including #8-32 x 2" SHCS (2) and M4 x 50mm SHCS (2)

CATALOG NUMBER	DESCRIPTION
CVe-EXT	External Mounting Block including #8-32 x 1" SHCS (2) and M4 x 25mm SHCS (2)



PROFILE[®] REAL-TIME MONITORING

PROFILE SYSTEM FEATURES:

Global Overview of Assets

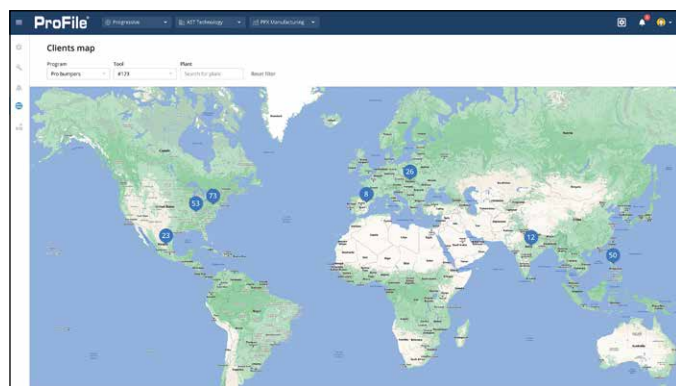
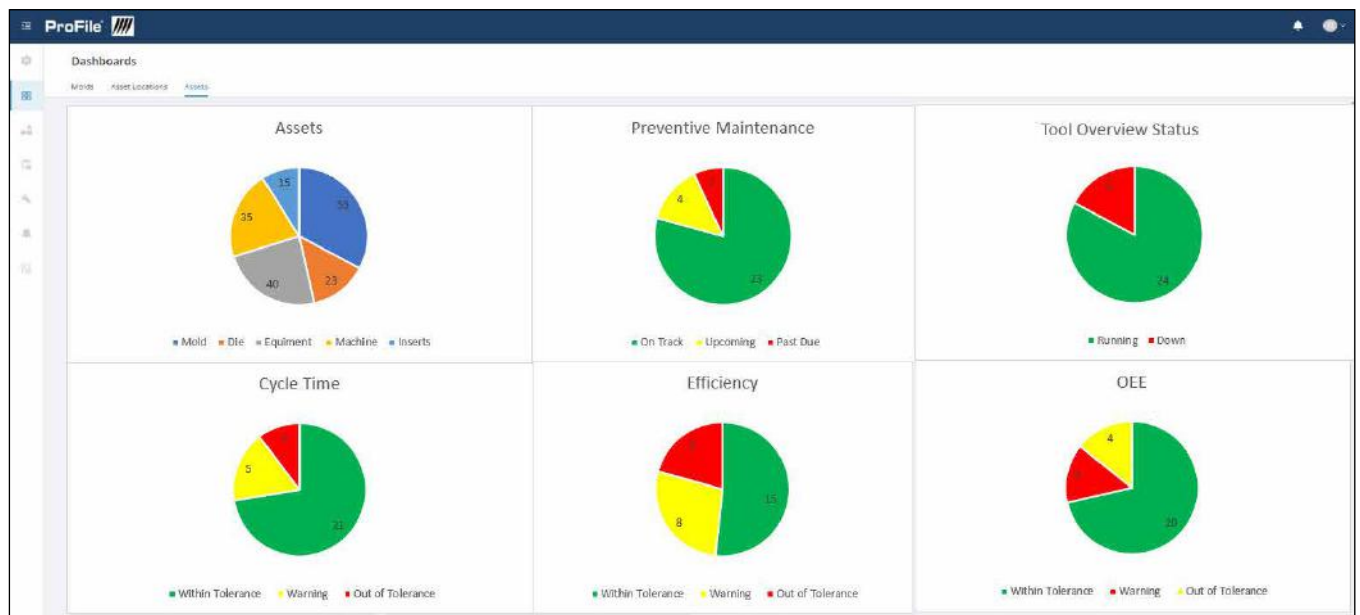
- Real time visibility of performance and key metrics.
- Monitor all assets: Molds, Machines, Dies and Equipment.
- Track mold condition, data, and GPS location.

Mold Maintenance & Repair

- Track Preventive Maintenance adherence.
- Process Work Orders using the integrated system.
- Track Spare Parts Inventory and Parts Consumed.
- Generate true cost of maintenance report.

Data Sharing

- Website can be accessed anywhere the internet is available.
- ProFile Mobile App for iOS and Android allows easy access.
- Filing Cabinet with 10GB per asset facilitates document sharing with stakeholders based on their role.
- Interface ProFile with existing ERP/MES systems using APIs.
- Utilize APIs to connect to report generating platforms.



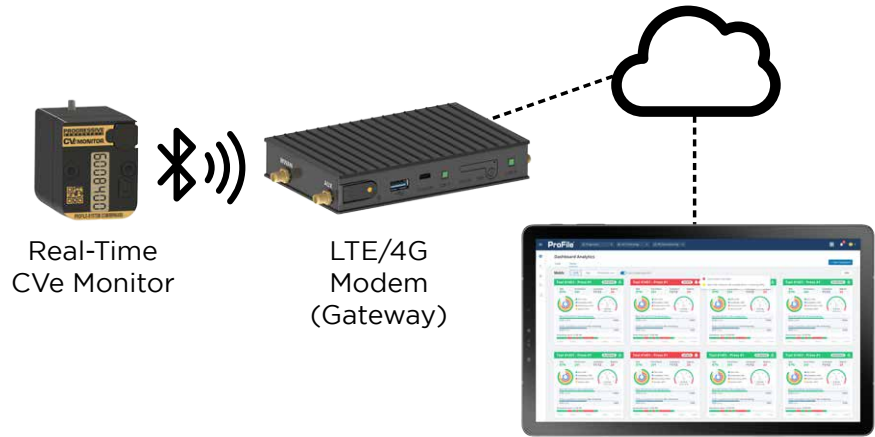
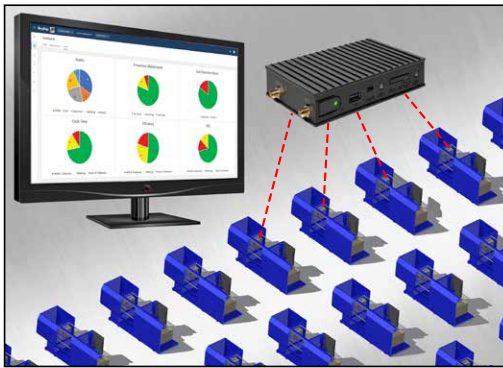
Global view of all assets by location, quantity, and class.



Customizable Performance Dashboard showing status and KPIs.

PROFILE® REAL-TIME MONITORING

For real-time monitoring of tools, Progressive provides hardware and website access for OEMs and molders utilizing the Real-Time CVE Monitors. For alternative OnDemand App use, refer to page F-9.







HARDWARE

Gateway

- Bluetooth® technology pushes tool data from the CVE Monitor to the cloud for real-time reporting.
- Utilizes FCC and CE certified internal components.
- One (1) Gateway per facility collects data from all CVE Monitors present on tools via Bluetooth transmissions.
- Range Extenders are available for long distances.
- Accesses the internet via cellular technology.
- Sends data to the customer’s web portal consistently.
- Includes SIM Card and related programming for regional use.

Cables & Accessories

- The PLC cable allows for connection from the CVE Monitor to the PLC for assembly or decorating.
- To connect to an external switch or when using with high speeds and heat applications, utilize the cable with the Magnetic Switch connection.
- Battery replacement kit includes installation instructions.
- Accessories below are exclusively used with the Real-Time CVE Monitor. Contact SystemMonitoring@procomps.com for a consultative quote on all items required for a single or multiple locations.

CATALOG NUMBER	DESCRIPTION	IMAGE
CVEL-GWBT	Real-Time Gateway North America version	
CVEL-GWBT-IN	Real-Time Gateway International version	
CVEL-BTEXT	Range Extender: RF Adapter to USB	
CVEL-BT-PLC	Cable: PLC Molex® Connector to White/Green/Black/Red Wires Wire: 72" (1800mm) Long	
CVEL-BT-SWT	Cable: PLC Molex® Connector to Magnetic Switch Switch & Magnet: .9"x.55" (23mmx14mm) Wire: 72" (1825mm) Long	
CVE-BTREPLKIT	Battery Replacement Kit for the Real-Time CVE Monitor Includes 2 batteries, housing seal, and Torx® wrench	

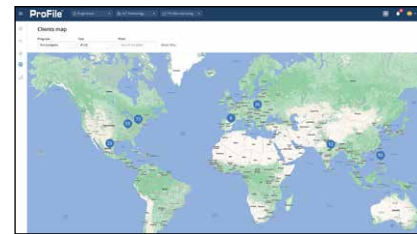
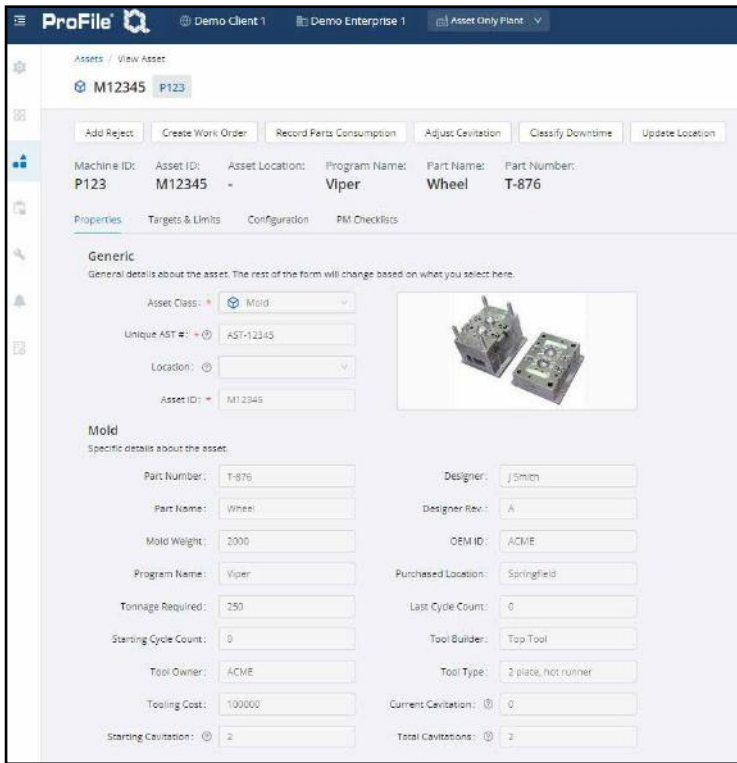


PROFILE® ASSET MANAGEMENT SYSTEM

The ProFile Asset Management System is a comprehensive solution for tracking assets. The cloud-based system organizes assets and stores related documents and photos, while also logging GPS locations.

Several options of Asset Tags and Plates are offered on the following page.

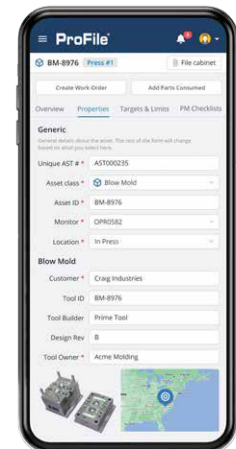
- Different asset types require different types of data. ProFile offers five asset classes (molds, dies, machines, equipment, and inserts) with customizable asset types under each class. There are also several user-defined fields to give users increased flexibility.
- Each asset page includes a filing cabinet to store critical documents associated with that asset. These documents can be easily accessed and shared by users with permissions. Users have 10GB of storage associated with their asset database.
- When logging in to ProFile via ProFile-System.com, the dashboard shows a breakdown of assets in the system by asset class. Clicking on any of the asset classes on the chart will drill down to the detailed listing. Also, the dashboard shows Preventive Maintenance status of assets for easy access to overdue PMs.
- See a complete list of all assets in one place or choose the tab for the asset class filter. All fields on the tool listing are sortable using the header fields.



Asset ID	Asset Image	Upcoming PM	Last GPS Scan	Last PMS	Current PMS	Part Number	Part Name	Action
4077728		●	1/19/2022, 11:47:01 PM	PL-PR053.01		T-876	Wheel	Switch Edit ...
4070003		●	2/18/22, 10:45:01 AM	PL-PR053.01		T-876	Wheel	Switch Edit ...

Mobile Functionality and GPS

- Scan the QR code on the Asset Tags or Plates on your mobile device to see a summary view of the asset. To see additional data, press the Details button. Every time a QR code is scanned, the GPS location is pushed to the cloud and recorded on the asset page.
- Preventive Maintenance and Work Orders can be scheduled.
- Users can create checklists and assign them to assets to view how many cycles or the date assets require maintenance. To schedule maintenance or other activities, Work Orders can be utilized to track unscheduled maintenance and repairs for assets.
- The ProFile Asset Management system can be used with both CounterView and CVE Monitoring devices via their unique serial number.
- For a demonstration or to set up an account for ProFile system access, contact SystemMonitoring@procomps.com.



PROFILE® ASSET TAGS AND PLATES

SPECIFICATIONS: STANDARD TAGS

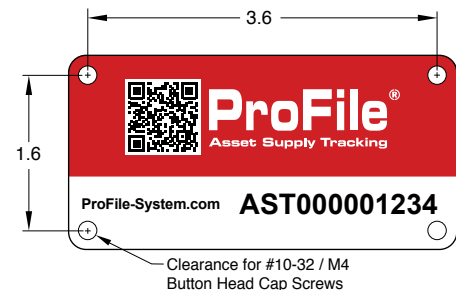
- ProFile account required and established at time of purchase. More information on the Asset Management system can be found on page F-5.
- Two sizes available. Small versions fit on CounterViews. Refer to page F-10 for CounterView specs.
- 8 mils thick aluminum, brushed finish.
- 3M 467 adhesive can be affixed to standard tool steel. Max temp 300°F (150°C).
- Serial number (AST prefix) is established by Progressive and aligns to customer-specific asset identification within ProFile-System.com.
- Minimum order quantity is 25 tags of any type and must be purchased in increments of 25.



CATALOG NUMBER	SIZE	DESCRIPTION
AMTG-S24	4" x 2" (101.6mmx50.8mm)	ProFile Asset Tag-Large
AMTG-S15	1.25" x .5" (31.7mmx212.7mm)	ProFile Asset Tag-Small

SPECIFICATIONS: STANDARD PLATES

- ProFile account required and established at time of purchase. More information on the Asset Management system can be found on page F-5.
- 20 mils thick aluminum.
- Provides heat resistance for assets up to 600°F (315°C).
- Bolts to mold base/asset with included button head cap screws.
- Minimum order quantity is 25 plates and must be purchased in increments of 25.



CATALOG NUMBER	SIZE	DESCRIPTION
AMTG-P24	4" x 2" (101.6mmx50.8mm)	ProFile Asset Plate

CUSTOM TAG & PLATE ORDERING INFORMATION

- Specifications are same as standard Tags and Plates, shown above.
- Layout is as shown at left below, but the text can vary based on your requirements as shown on the sample at right. Also, the color can be selected to match your company's logos. All custom Tags/Plates include the QR code and unique serial number. Refer to the template at procomps.com to submit your quote request.
- Minimum order quantity = 50 for 4x2" Plates and Tags; 100 for the 1.25 x .5" tags.
- Delivery for initial order is 3 weeks, including proof time.





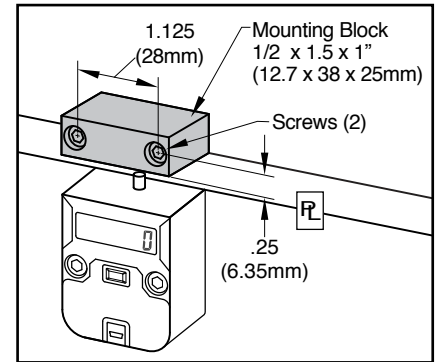
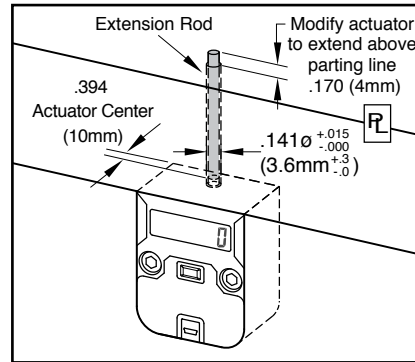
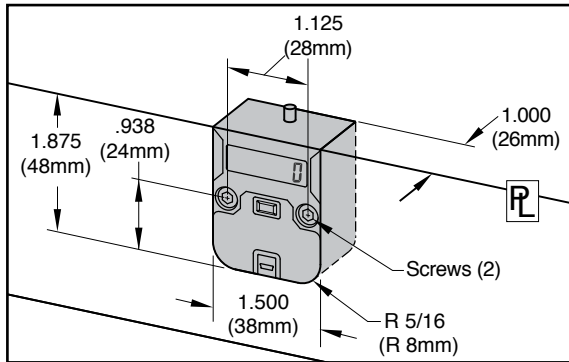
CVe MONITOR® ONDEMAND MOLD MONITORING

APPLICATION GUIDELINES

- Progressive's OnDemand CVe Monitor tracks tool activity, allowing users to view data on the display or from comprehensive reports using the free PC-based OnDemand application.
- 7-digit LCD display with a push button to move through the display modes.
- 16GB flash drive included for file storage. Replaceable battery.
- Water resistant with an ingress protection rating of IP52.
- Maximum temperature: 190°F (90°C). For protection against higher temperatures, refer to the Insulators available on pages F-12 and F-13.
- Dimensional compatibility with Progressive's mechanical CounterViews.
- Mini USB connectivity for data retrieval with cables sold separately on page F-8.
- Cover Plates for protection are sold separately on page F-14.



MOUNTING OPTIONS



CATALOG NUMBER	DESCRIPTION
CVE	CVe Monitor including #8-32 x 1" SHCS (2) and M4 x 25mm SHCS (2)

CATALOG NUMBER	DESCRIPTION
CVE-INT	Internal Extension Rod (8"/200mm)
CVE-EXT	External Mounting Block including #8-32 x 1" SHCS (2) and M4 x 25mm SHCS (2)

To Order:

- For installation below parting line (rails as shown in the center graphic above), order the CVE and CVE-INT.
- For installation outside of the mold (right graphic), order the CVE and CVE-EXT.

ON-MOLD DISPLAY MODES

Each device is provided at -25 cycles to allow for mold set up and initialization of the CVe Monitor. Once it reaches zero (0), all timers and data will reset on the monitor. During production, users can press the button on the front of the monitor and review the following information on the display:

Cycle Count

Total cycles for the life of the mold is presented on the main screen.



Efficiency Percentage

The percentage of time that the mold has been actively cycling vs being idle.



Cycle Time

Since the first production cycle, cycle time for the life of the mold.



Efficiency Percentage-Recent

The percentage of time the mold has been active in the past 500 cycles.



Cycle Time-Recent

Cycle time for the past 500 cycles is shown in seconds.



Cycle Count Reset

Press and hold button to reset separate counter to 0 for interim monitoring of cycles.



Mold Temperature

View current temperature experienced by the monitor (°C) by pressing button twice.



Flash Drive

Utilize the 16GB flash drive by connecting the CVe to a PC/Tablet with an industry-standard mini USB cable, sold on page F-8.



CVE MONITOR®

ONDEMAND MOLD MONITORING

Once data is initialized using the complimentary OnDemand software (from procomps.com/cve-ondemand), users can choose to be alerted to the following sets of conditions for the OnDemand CVE Monitor.

Preventive Maintenance

During initialization, Preventive Maintenance (PM) checkpoints are entered and saved onto the OnDemand CVE Monitor. If a PM checkpoint is exceeded, the monitor enters the PM alert mode and displays both a wrench icon and PM Due as shown at right.



When PM is performed and entered via OnDemand or by the in-mold actuation/button push combination, the next checkpoint for the PM will be written. If no PM is performed, the OnDemand CVE Monitor will remain in PM alert mode until the user performs all PMs whose thresholds have been exceeded.

Cycle Time

During initialization, the target cycle time can be written to the monitor using OnDemand. Any variation greater than 2% from the target will enter the alert mode and display the clock icon as shown at right. When the cycle time returns to within 2% of the target, the alert is removed.



Efficiency

During initialization, the target efficiency can be written to the monitor using OnDemand. Any variation greater than 2% from the target will enter the alert mode and display the percentage (%) icon as shown at right. When the efficiency returns to within 2% of the target, the alert is removed.



Low Battery

The OnDemand CVE Monitor has a battery life of approximately 4 years in typical molding environments where temperatures are controlled. (The battery is 1/2AA lithium non-rechargeable with 3.6V.) When the battery reaches a specified level, the display will show a battery icon as shown at right, and the replacement kit can be ordered separately below.



RETROFITTING

Users can view additional data by double-clicking the button on the monitor.

Retrofit CVE for CounterView Tools

During initialization, molders can start the cycle count with the tool's actual cycle count from an existing CounterView or known cycles from maintenance records. Once entered, the user can see the total cycles for the tool, which includes the count of the cycles from the counter and those run with the CVE Monitor.



In the graphic at right, the tool had 1,000,000 cycles on it originally, but ran 507,288 after the OnDemand CVE Monitor was installed.



CABLES AND CONNECTIVITY

Using a USB cable, users can connect the OnDemand CVE Monitor to their computer or tablet and view data in OnDemand, outlining the reason for the report generation. Notes can be included and user information is recorded for historical reference. More details about OnDemand are on the following pages.



OnDemand Activity Log [Software Version 3.1.0/2.6.1/3.1.9]									
Cve Initialize Date	November 23, 2017	December 17, 2017							
Device ID	OKX1234	OKX1234							
Tool ID	85658	85658							
Part ID	Blower Housing	Blower Housing							
Program Name	ABT57	ABT57							
Customer	Mocha	Mocha							
Target Efficiency%	Crimson Fan	Crimson Fan							
Target Cycle Time	N/A	94%							
Initial PM Point	N/A	7.5							
Target PM Interval	50000	50000							
Cycles Prior to Cve Installation*	1000000	1000000							
DEM ID	N/A	ABT1							
ASSET ID	N/A	0356-5686							
Reason for connecting CVE Monitor									
Date/Tms	Battery	Cycles	OD User	Conn. By	Company	Destination	REV	REV	Notes
October 4, 2018	OK	507,288	INIECT1	Blake Fitz	Injection Tech	Crimson@crimson.com	N	N	N/A Replaced damaged core pin in cavity 4
October 4, 2018	OK	506,524	INIECT1	Blake Fitz	Injection Tech	Crimson@crimson.com	N	N	N/A Data Pull
September 19, 2018	OK	491,274	INIECT1	Blake Fitz	Injection Tech	Crimson@crimson.com	N	N	N/A Pulled from production for mold operational issues. It is being sent to evaluation and rework
September 7, 2018	OK	484,567	MOLDHOU1	Chuck Louse	Mold House	Crimson@crimson.com	N	Y	N/A Full PM. Cavity #2 was shutoff
June 28, 2018	OK	364,001	MOLDHOU1	Chuck Louse	Mold House	Crimson@crimson.com	N	Y	N/A Full PM
May 31, 2018	OK	314,856	MOLDHOU1	Chuck Louse	Mold House	Crimson@crimson.com	N	Y	N/A Full PM
April 28, 2018	OK	260,002	MOLDHOU1	Chuck Louse	Mold House	Crimson@crimson.com	N	Y	N/A Full PM. Cavity #2 was shutoff
April 4, 2018	OK	211,563	MOLDHOU1	Chuck Louse	Mold House	Crimson@crimson.com	N	Y	N/A Full PM
March 22, 2018	OK	193,268	INIECT1	Blake Fitz	Injection Tech	Crimson@crimson.com	N	Y	N/A 3 cavities are shutdown. Pulled for evaluation and repair
February 7, 2018	OK	106,235	MOLDHOU1	Chuck Louse	Mold House	Crimson@crimson.com	N	Y	N/A Full PM
January 10, 2018	OK	58,725	MOLDHOU1	Chuck Louse	Mold House	Crimson@crimson.com	N	Y	N/A Full PM
December 17, 2017	OK	9,265	MOLDHOU1	Chuck Louse	Mold House	Crimson@crimson.com	N	Y	N/A Initial mold inspection. There is no wear or damage to mold follow initial run. Targets are set. Mold is released for production
November 23, 2017	OK	0	MOLDHOU1	Chuck Louse	Mold House	Crimson@crimson.com	N	N	N/A Mold is completed and released for sampling

CATALOG NUMBER	DESCRIPTION
CVEL-DATA9	USB 2.0 to Type B Mini 9 Foot, Right-Angle Cable
CVEL-DATA9S	USB A to Type B Mini 9 Foot, Straight Cable
CVE-USB-15	USB 2.0 to Type B Mini, 15 Foot, Common Straight Cable
CVE-REPLKIT	Battery Replacement Kit for the CVE Monitor



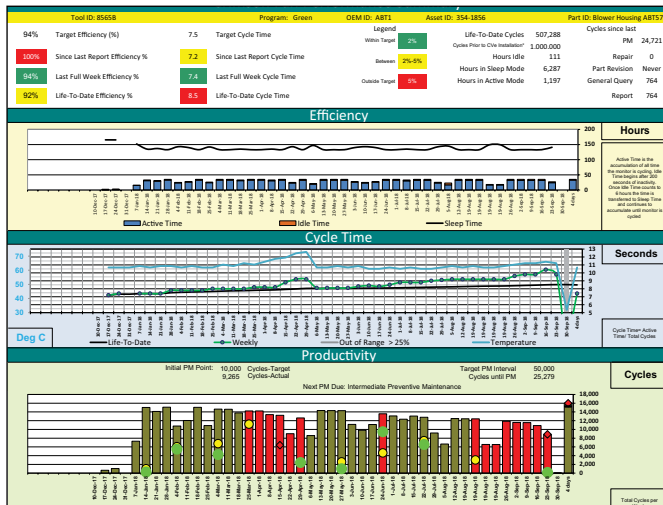
ONDEMAND®

Drive comprehensive reporting using data from the CVE Monitors. Availability for the specific version CVE Monitor is outlined below, but both applications have the following features:

- When the CVE is initialized, users can identify their tool and align all reports with the device serial number which is tracked throughout the application.
- Ten languages supported: English, German, Mandarin, Spanish, French, Italian, Japanese, Korean, Portuguese and Thai. Reports are generated in the chosen language.
- Users can view statistics on a particular tool, review productivity for preventive maintenance (PM), as well as other actual data compared to targets established by the mold.
- Users can also view weekly cycle time and maximum mold temperature tracking with variances over time.
- Both the PC-based software and the App are free of charge but must be utilized with the specific CVE Monitor version that supports the interface.

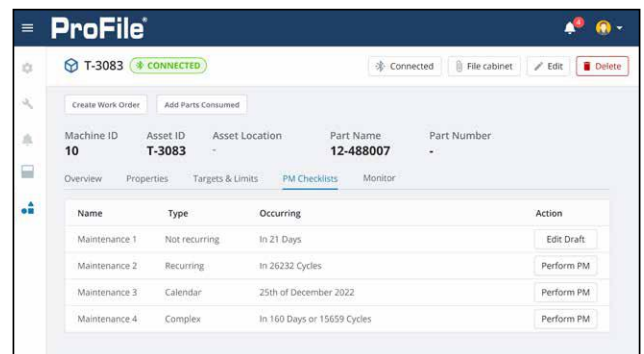
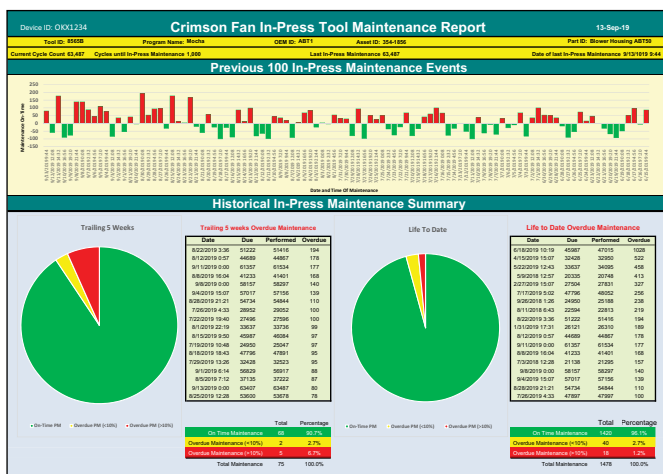
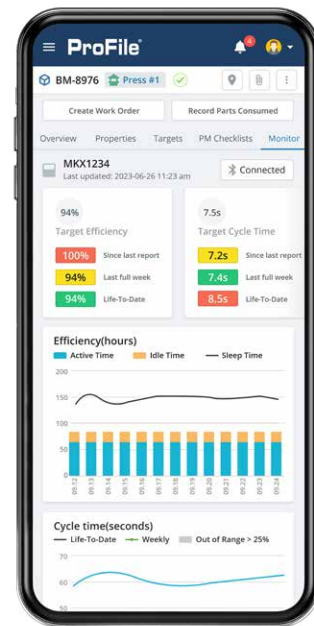
FOR THE ONDEMAND CVE MONITOR

- Utilize the PC-based system and cables available on the previous page.
- Download from procomps.com/cve-ondemand.



FOR THE REAL-TIME CVE MONITOR

- Use the ProFile Mobile Application on phones or tablets. No cables or PC required.
- Download from Apple and Google Play stores.



Users initialize the CVE Monitor using the PC-based OnDemand program and can set their targets accordingly.

Standard reports show variances between actual and target data, and the reports can be emailed to stakeholders for analysis.

Users can initialize the Real-Time CVE Monitor via the QR code on the face of the monitor or call up the record within the application using the serial number.

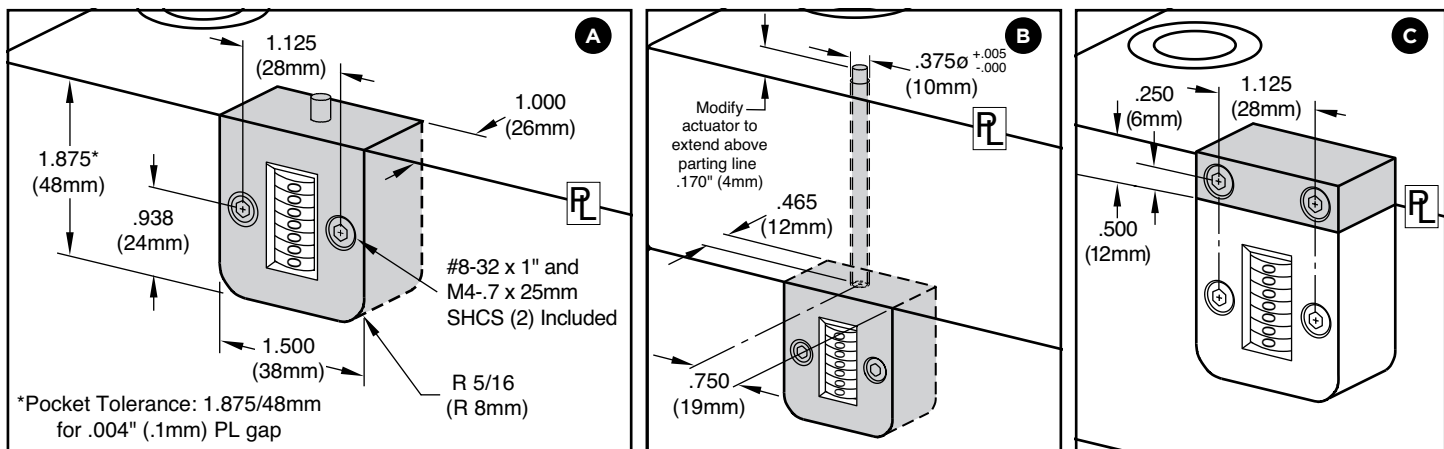
Targets are set within the App and standardized reports can be generated and emailed, while data can also be exported and shared.

COUNTERVIEW® S-SERIES



- ### APPLICATION GUIDELINES
- Maximum operating temperatures:
 - 250°F (120°C) Standard CounterView
 - 375°F (190°C) High Temp CounterView
 - Counter: Non-resettable mechanical, 7-digit
 - Available for installation on the movable or stationary halves and with extensions.
 - For heat protection, refer to the Insulators available on pages F-12 and F-13.
 - Cover Plates for protection are sold separately on page F-14.
 - CounterViews can be ordered pre-set to a specific cycle count. Contact Customer Service for more information.

M Glass-filled Nylon housing



Mounting Options

Parting Line Mount	A	Parting line mount makes unit easily visible to operator.
Internal Extension Mount	B	Machinable 8" (200mm) included extension rod allows installation in support plate or rail. Not available for High Temp CounterViews.
External Mount	C	No pocket machining necessary. Designed specifically for retrofit applications. Order the Parting Line Mount and the CVE-EXT Block as shown below.

Operator Side: Movable Half / B Side



Operator Side: Stationary Half / A Side



CATALOG NUMBER	VERSION & MOUNTING STYLE
CVPL-B	Standard: Parting Line
CVIN-B	Standard: Internal Extension
CVPLHT-B	High Temp: Parting Line

Screws included.

CATALOG NUMBER	VERSION & MOUNTING STYLE
CVPL-A	Standard: Parting Line
CVIN-A	Standard: Internal Extension
CVPLHT-A	High Temp: Parting Line

Screws included.

ACCESSORIES



CATALOG NUMBER	DESCRIPTION
CVE-EXT	External Mounting Block including #8-32 x 1" (2) and M4 x 25mm screws (2)
CVID	ID Plate for CounterView



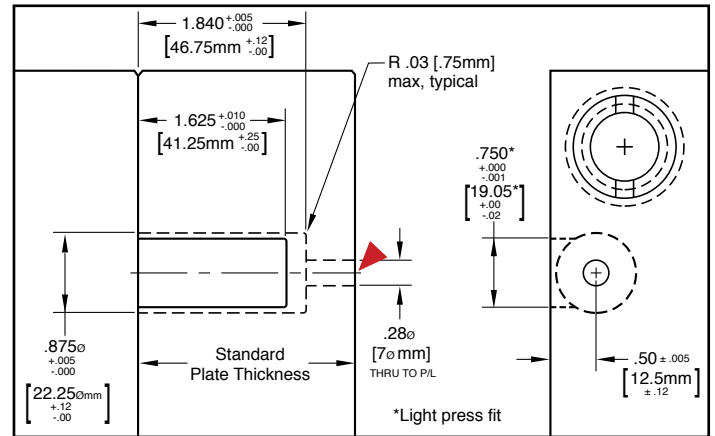
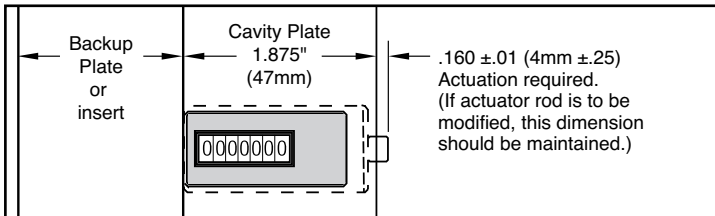
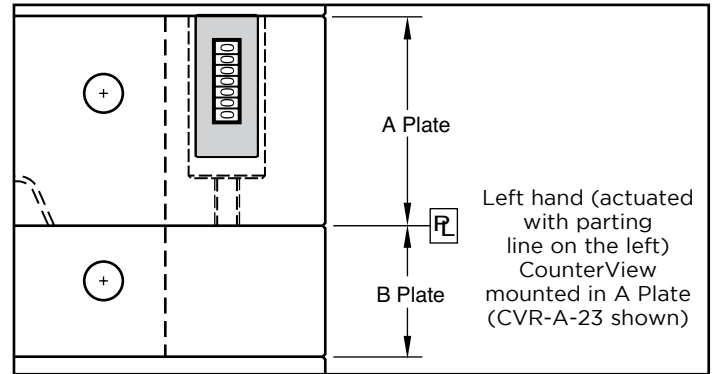
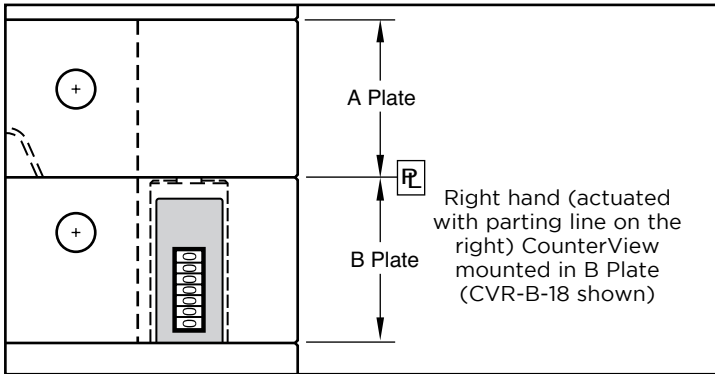
COUNTERVIEW® R-SERIES

APPLICATION GUIDELINES

- Counter: Non-resettable mechanical, 7-digit
- Available for installation on the movable or stationary halves and with extensions.
- Maximum operating temperature is 250°F (120°C). For heat protection, refer to the Insulator available on page F-12.
- CounterViews can be ordered pre-set to a specific cycle count. Contact Customer Service for more information.



M Glass-filled Nylon housing



The R-Series CounterView can be installed in the A or B plates with a minimum thickness of 1.875" (47mm). Larger plates utilize a threaded rod (included with each) that is pre-machined to the appropriate length for standard plate thicknesses to provide consistent actuation.

Operator Side: Movable Half / B Side



Operator Side: Stationary Half / A Side



Inch Standard

CATALOG NUMBER	NOMINAL PLATE THICKNESS
CVR-B-18	1.875
CVR-B-23	2.375
CVR-B-28	2.875
CVR-B-33	3.375
CVR-B-38	3.875
CVR-B-43	4.375
CVR-B-83	8.375

Metric Standard

CATALOG NUMBER	NOMINAL PLATE THICKNESS
CVR-B-56	56
CVR-B-66	66
CVR-B-76	76
CVR-B-96	96
CVR-B-116	116
CVR-B-196	196

Inch Standard

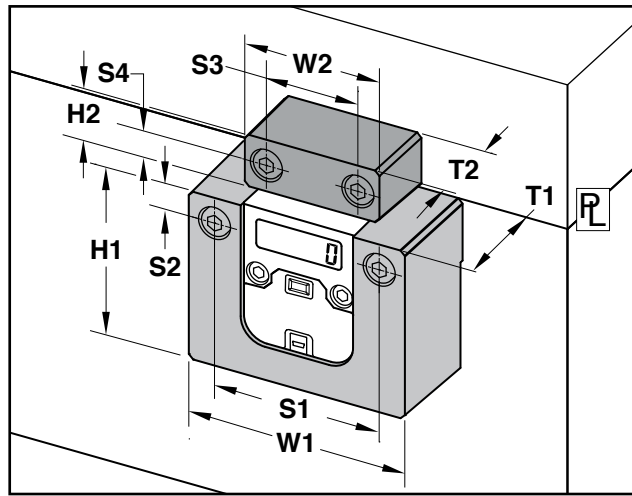
CATALOG NUMBER	NOMINAL PLATE THICKNESS
CVR-A-18	1.875
CVR-A-23	2.375
CVR-A-28	2.875
CVR-A-33	3.375
CVR-A-38	3.875
CVR-A-43	4.375
CVR-A-83	8.375

Metric Standard

CATALOG NUMBER	NOMINAL PLATE THICKNESS
CVR-A-56	56
CVR-A-66	66
CVR-A-76	76
CVR-A-96	96
CVR-A-116	116
CVR-A-196	196

Each R-Series CounterView includes the actuator. All except CVR-B-18 and CVR-A-18 require attachment of the actuator rod to the threaded CounterView unit.

INSULATOR BLOCKS EXTERNAL MOUNT



APPLICATION GUIDELINES

- Maximum temperature: 360°F (180°C).
- Installation can be on the cavity or core half of the tool. For use with ProFile, mount to the stationary half for optimum cable routing.
- The Insulator Block accepts the screws from the S-Series CounterView sold on page F-10 or the OnDemand Cve Monitor sold on page F-7. Can be utilized with the Real-Time Cve Monitor sold on page F-2, but it will protrude outside of the block.

M Vadyne

CATALOG NUMBER	DESCRIPTION	HI	WI	TI	SI	S2	H2	W2	T2	S3	S4
CV-BLK	Inch version with screws: (2) 1/4-20 x 1-1/8 (Actuator) (2) 1/4-20 x 1-1/2 (Block)	2.37	3.00	1.37	2.25	.50	.75	2.00	1.00	1.00	.37
CVMM-BLK	Metric version with screws: (2) M6-1.0 x 30 (Actuator) (2) M6-1.0 x 40 (Block)	60	76	35	57	12.5	19	50	25	25.5	9.5

R-SERIES COUNTERVIEW INSULATOR BLOCK

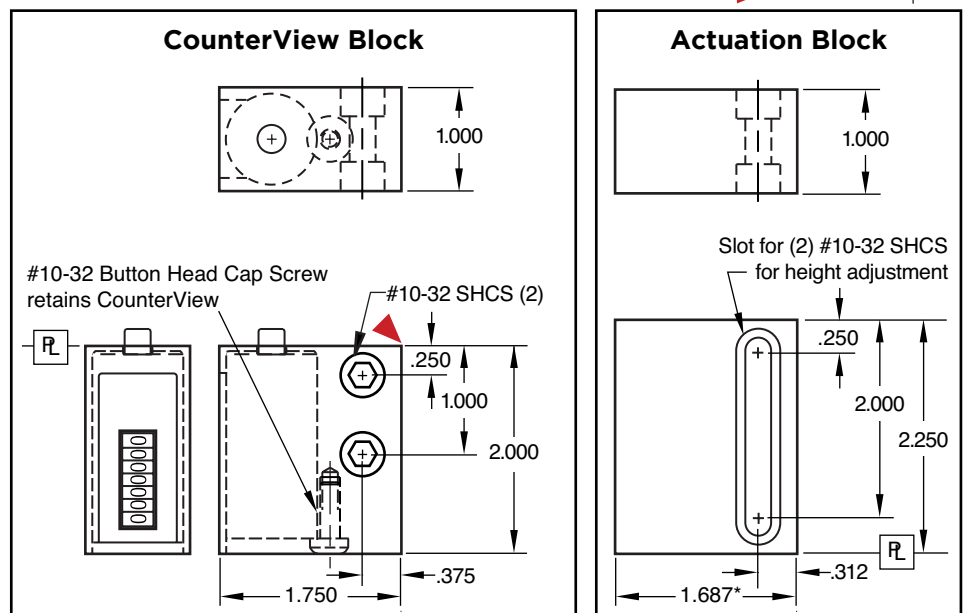


M A36 **S** Black Oxide

CATALOG NUMBER	DESCRIPTION
CVRA-100	CounterView Attachment Block Set (Includes Screws)

R-Series CounterViews are sold separately on page F-11.

► CAD insertion point



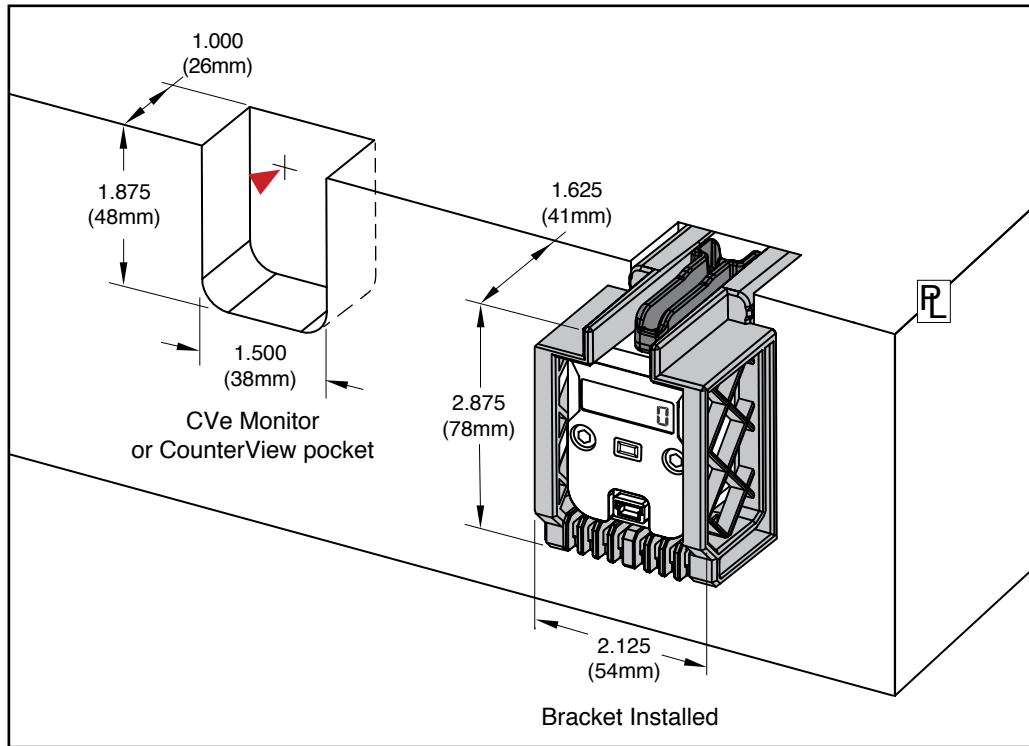
Note: The width of the Actuation Block is smaller by 1/16" to allow for clearance if the CounterView Block is recessed into the mold.



INSULATOR BLOCKS RETROFIT BRACKET



▶ CAD insertion point



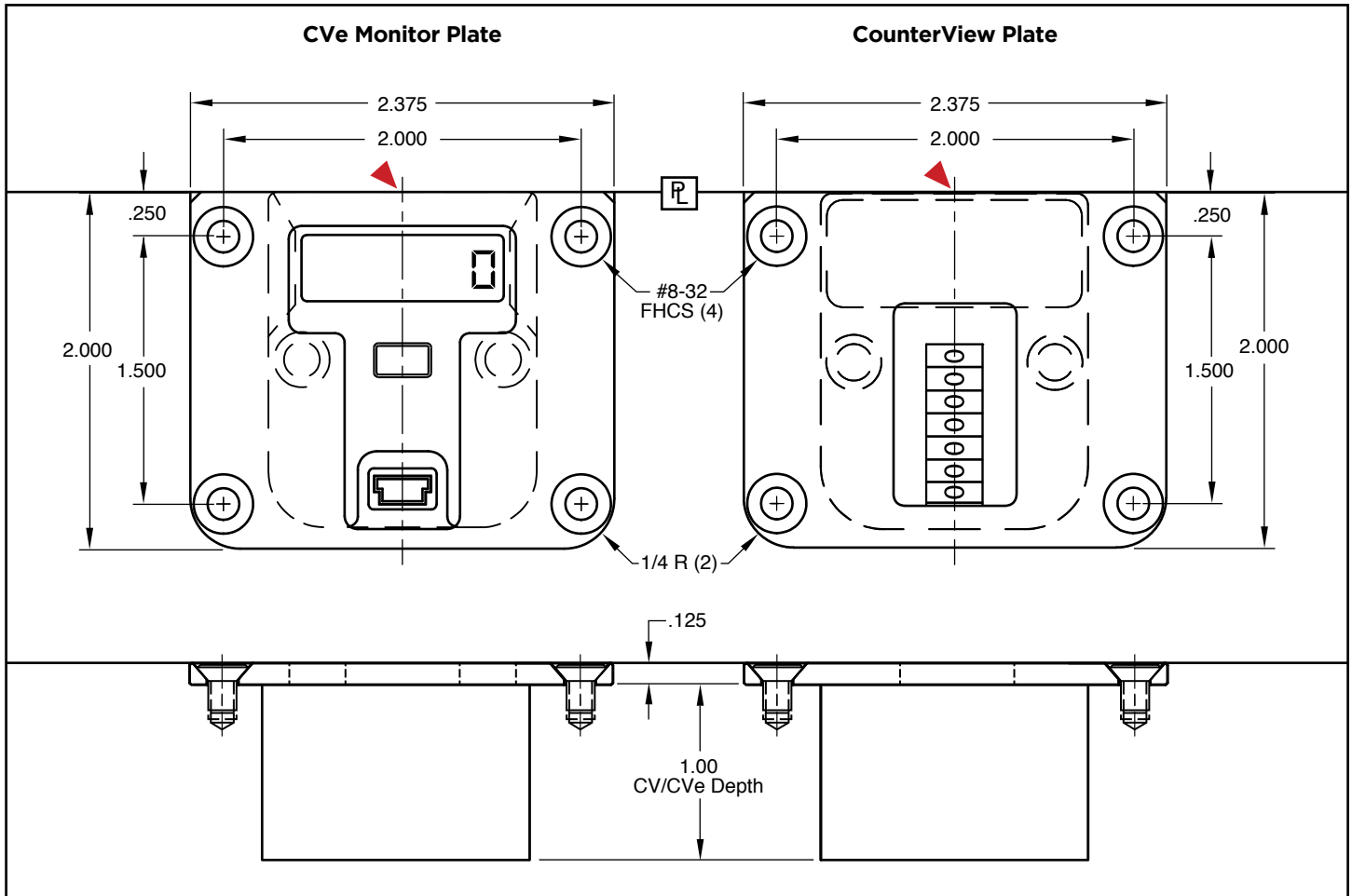
M Vadyne

CATALOG NUMBER	DESCRIPTION
CV-BRACKET	Inch version with screws: (2) #8-32 x 1-1/2
CVMM-BRACKET	Metric version with screws: (2) M4-.7 x 35mm

APPLICATION GUIDELINES

- Maximum temperature: 410°F (210°C).
- The Inch or Metric Insulator Block assembly sits in the pocket as shown above, and utilizes the screw locations from the square CounterView sold on page F-10 or the OnDemand CVe Monitor sold on page F-7.
- The Bracket can be installed on the cavity or core half of the tool. For use with OnDemand CVe Monitors using the ProFile system, mount to the stationary half for optimal cable routing. The Bracket can be utilized with the Real-Time CVe Monitor sold on page F-2, but the monitor will protrude 1" outside of the tool.
- The CVe Monitor or CounterView are actuated via a Striker which is attached to the Insulator Bracket as a single unit. No preload adjustment is required.

COVER PLATES



▶ CAD insertion point

M 1018 **H** 135 Brinell **S** Black Oxide

CATALOG NUMBER	DESCRIPTION
CVE-PLT	CVe Monitor Cover Plate with (4) #8-32 x 5/16 long FHCS
CV-PLT	CounterView Cover Plate with (4) #8-32 x 5/16 long FHCS

APPLICATION GUIDELINES

- Cover Plates can be used for both the A-Side and B-Side mounting options for the CounterViews sold separately on page F-10.
- OnDemand CVe Monitors are sold separately on page F-7.
- The Cover Plates can be installed flush to the outside of the mold base by adjusting the depth of the pocket for the CVe Monitor or CounterView by the 1/8" thickness of the plate. If mounting on outside of the base, no pocket adjustment is needed.

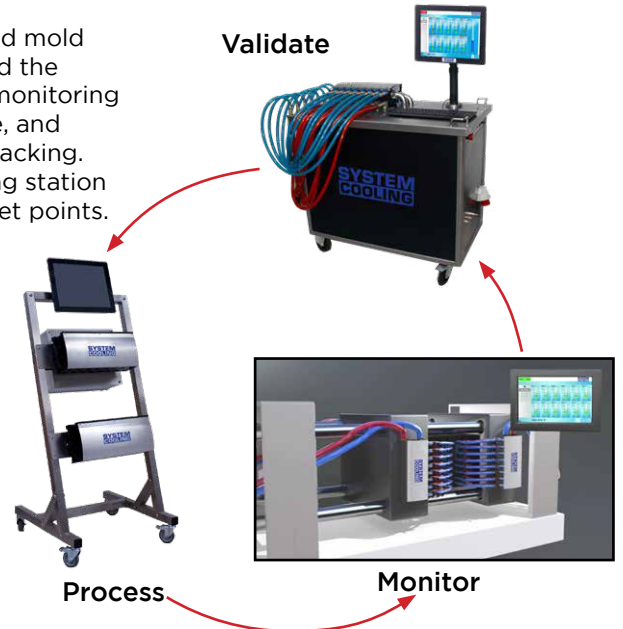


SYSTEM COOLING™ MOLD COOLING MONITORING

System Cooling is a suite of products that allows injection molders and mold makers to collect and view data on the cooling lines within a mold and the cooling parameters during production. Molders utilizing the process monitoring system can view and collect data related to coolant flow, temperature, and pressure with information recorded and time stamped for historical tracking. Mold makers and tool room managers can utilize the Test Rig, a testing station that analyzes the mold for flow capacity, leaks, and optimal process set points.

Benefits:

- Allows for troubleshooting of quality inconsistencies.
- Alarms when process deviations are detected, reducing scrap.
- Reduces setup errors by the detection of flow constraints due to closed valves or dead-headed circuits.
- Identifies flow deviations from long-term corrosion build up, blockages, or equipment faults.
- Identifies temperature deviations and fluctuations from cycle time changes, unauthorized adjustments, or equipment faults.
- Validations certify that molds are production-ready.
- Aids in scheduling maintenance intervals based on past analysis and historical data, while also providing reporting capabilities.



SYSTEM COOLING™ MANIFOLDS

The instrumented manifold takes the place of traditional distribution manifolds on molding machines. Its compact form and stainless steel construction grants versatility in a variety of applications from harsh environments to space-limited configurations and clean rooms. The flow sensors operate on the vortex flow principle without any moving parts. Manifolds can be mounted to the molding machine or a separate cart.

Manifolds monitor:

- Supply temperature
- Supply pressure
- Return temperature by zone
- Flow by zone
- Return pressure

Additional features include:

- Main supply and return ports on both top and bottom of manifold provide flexibility.
- No moving parts and large unrestricted flow path.
- Color-coded ball valves and 300 series connectors installed.
- Maximum temperature: 250°F (120°C)



ORDERING INFORMATION

ZONES	FLOW RANGE	CATALOG NUMBER
4	.25-5.25 GPM / 1-20 LPM	SCM-4-1-SS-HT
	.5-10.5 GPM / 2-40 LPM	SCM-4-2-SS-HT
8	.25-5.25 GPM / 1-20 LPM	SCM-8-1-SS-HT
	.5-10.5 GPM / 2-40 LPM	SCM-8-2-SS-HT
12	.25-5.25 GPM / 1-20 LPM	SCM-12-1-SS-HT
	.5-10.5 GPM / 2-40 LPM	SCM-12-2-SS-HT



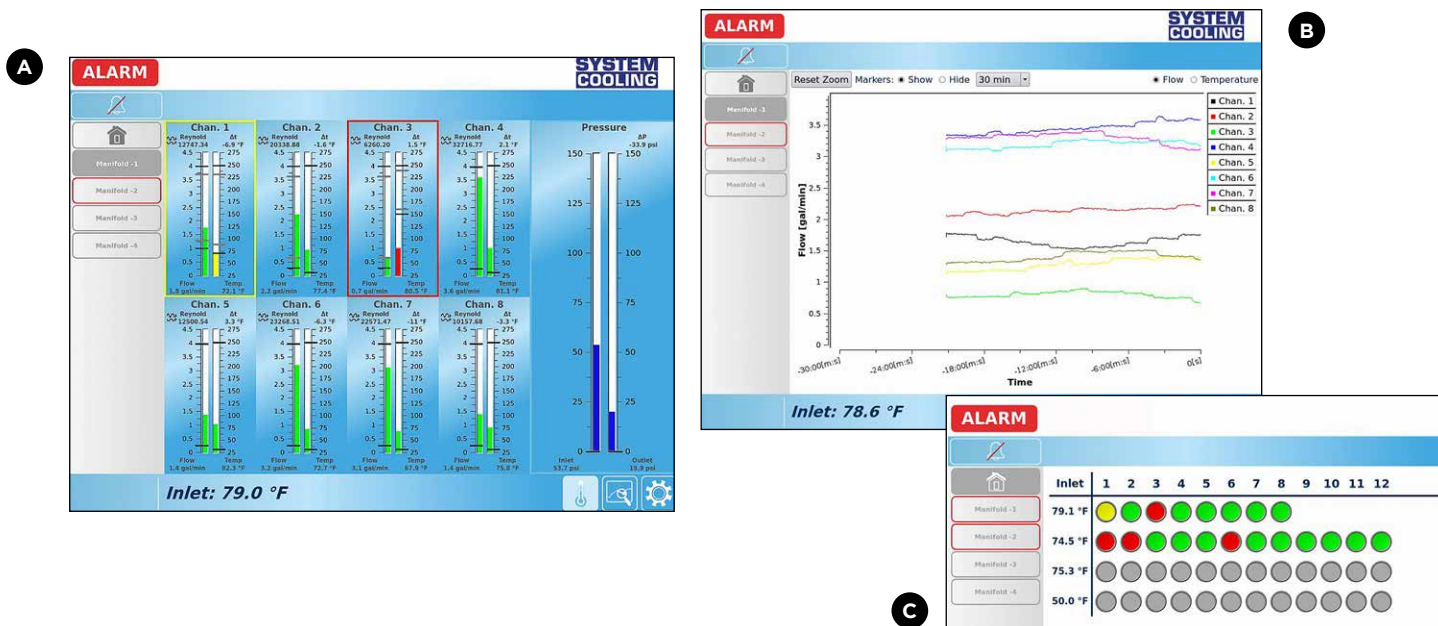
Flow and temperature are measured in each zone individually.

Monitoring system consists of Manifolds and required electronics. Please contact SystemMonitoring@procomps.com for system information and quotes.

SYSTEM COOLING™ SOFTWARE

The System Cooling software interface is easy to use with only five screens to navigate. The system provides real-time information, historical data, and profiles (mold ID, circuit names, and data thresholds) for mold management:

- A Information Display**
 - Temperature deltas between supply and return are calculated per zone.
 - Reynolds numbers are calculated per zone, and laminar, transitional, or turbulent status is displayed.
 - Alarms are activated per monitored parameter based on the profiles of the molds.
- B Historical Data**
 - Graphs present data for the most recent two hours of production.
 - Data can be exported via USB or by network connection for viewing in Excel or additional systems.
- C System Overview**
 - The status of the entire system, all zones of all manifolds, can be viewed at a glance.



MOUNTING

The System Cooling Monitoring System can either be permanently installed on a molding machine or mounted to a mobile cart as shown on the following page.

When mounted to a machine, the System Cooling I/O module, included with every system, can communicate to external devices such as the molding machine, part diverters, stack lights, and data networks.

- Alarm or warning state can switch molding machine to semi-auto or manual mode.
- Part diverters can automatically separate nonconforming parts.
- Illuminate stack lights for visibility to technicians.
- Data markers from the molding machine, typically at the beginning of each cycle, can be accepted and overlaid on the data.
- Machine idle state input signals the system to suppress alarm output during alarm state.

The system is also VNC capable, eliminating the need for a touchscreen controller. The interface can be accessed via VNC from a smartphone, laptop, or the machine controller.

Note: Molding presses must be verified for compatibility.





SYSTEM COOLING™ PORTABLE CART

As an alternative to permanently dedicating System Cooling to a press, the system can be mounted to a mobile cart.

Applications that can benefit from a mobile cart include:

- Troubleshooting
- Process development for new molds.
- Ad-hoc projects and validation efforts.
- On the standard carts, one or two manifolds can be mounted. Custom configurations are also available by contacting Customer Service.

Ordering Information

CATALOG NUMBER	TYPE
SCP-CART	Portable Cart for 4/8/12 Zone Manifolds



SYSTEM SPECIFICATIONS

Contact SystemMonitoring@procomps.com for additional specifications or questions.

MANIFOLD SPECIFICATIONS	
Manifold Feed Ports	1" BSPP
Circuit Ports	3/8 (-1) or 1/2 (-2) NPT
Regulation	Color-Coded Ball Valves
Connections	300 Series Quick Connectors
Maximum Pressure	145 PSI
Maximum Temperature	250° F / 120° C
Flow Sensor Type	Vortex
Accuracy-Flow	1.5% fs
Accuracy-Temperature	+/- 1.5% fs
Resolution-Temperature	0.9°F/0.5°C
Response Time	< 1 s
Seals	EPDM

SOFTWARE & ELECTRONICS SPECIFICATIONS	
Display	15.6" Touch Screen
Communication Ports	Ethernet / USB
Communication system	ASCII (USB)/HTML/SSH (optional)/VNC
Supported Protocols	USB Serial / TCP / IP
Machine Controller Integration	VNC
Maximum Supported Manifolds	8 Manifolds / 96 Zones
Display Units	°C, LPM, Bar / °F, GPM, PSI
Alarm Units	User Defined
Warning Limits	10% of alarm limits (optional)
Alarm & Warning Output	N/C and N/O Dry Contacts
Marker Input	24 VDC Galvanically Isolated
Idle Input	24 VDC Galvanically Isolated
Power Supply	12-24 VDC

SYSTEM COOLING™ TEST RIG

The Test Rig analyzes molds to validate, maintain, and optimize processes. The Rig runs flow capacity and pressure leak tests, and the premium version also determines optimal cooling process parameters. Reports are generated from the results and can be sent, saved, or printed. The Test Rig is a standalone test station equipped with a water reservoir, pump, 8-zone manifold, and unique control system and offered with three different models for customer applications.

New Molds

Mold makers are able to provide new tools to the customer complete with a report of operating parameters, including data relating to the cooling circuits in the mold. Traceable documentation of design validation for flow capacity under simulated production conditions and leak testing is provided by the Test Rig. These benchmarks are vital for any quality assurance process and establish a baseline for future comparisons.

Mold Maintenance

Mold cooling circuits need to be maintained regularly to remove scale and rust to ensure maximum productivity. With the Test Rig, the cooling channels can be analyzed and tested easily. The pressure can be precisely controlled by the variable output pump through the user interface to simulate the production environment. Each report can be compared against the baseline values to determine required maintenance and establish maintenance intervals for future service. The test results certify that a mold has regained flow capacity values and is in ready to run condition before being sent back to production.

Process Optimization

The cooling circuit flow capability at a given supply pressure is determined by the flow capacity test. The additional optimization executed by the extended flow test within the premium version determines the minimum required supply pressure to achieve maximum flow. This aids in defining process parameters to conserve central cooling supply capacity, potentially leading to reduced energy consumption.



Ordering Information

CATALOG NUMBER	FLOW RANGE
SCTR-1*	8 Zone Test Rig - .25-4 GPM / 1-15 LPM
SCTR-2*	8 Zone Test Rig - .5-10.5 GPM / 2-40 LPM

Specify the Test Rig catalog number above followed by the model suffix shown at right. Ex: SCTR-2-M will be the Test Rig Premium Model with the higher flow range.

TEST RIG SPECIFICATIONS	
Zones	8
Regulation	Color Coded Ball Valves
Connections	300 Series Quick Connectors
Flow Sensor Type	Vortex
Accuracy - Flow	1.5% fs
Max Total Flow	32 GPM / 120 LPM
Max Pump Pressure	58 PSI
Max Rated Pressure	145 PSI
Seals	EPDM
Display Units	°C, LPM ,Bar / °F, GPM, PSI
Ports	Ethernet and USB
Power Requirements	480v 60Hz 5A

MODEL TYPE	FEATURES
Test Rig Basic (-B)	<ul style="list-style-type: none"> Flow capacity and leak tests Plug and play, ready for testing Ports for data export or networking
Test Rig Plus (-P)	Includes basic Test Rig features, plus: <ul style="list-style-type: none"> Advanced software with extended flow optimization test. Built-in WiFi router capable of sending reports directly to a printer
Test Rig Premium (-M)	Includes the same features as the Plus model and adds: <ul style="list-style-type: none"> Automatic water change system



SLIDE COMPONENTS CAMACTIONS

SECTION G



CamAction 100 Series	CamAction 200 Series	CamAction 250 Series	CamAction 300/350 Series
Prefix: CA, CMM	Prefix: CA, CMM	Prefix: CA	Prefix: CA, CMM
Page: G-2	Page: G-3	Page: G-4	Page: G-5 - G-8



CamAction 400 Series	Slide Retainers & Cleats	SRT Bases & Bushings	SRT Slide Lock Style & Cleats
Prefix: CA	Prefix: SRT, SRTM	Prefix: SRTBA, SRTBU	Prefix: SRTLK
Page: G-9	Page: G-14 & G-15	Page: G-16	Page: G-17



Square Gibs	Center Guides	Wear Strips	Wear Plates
Prefix: SG	Prefix: CG	Prefix: WS	Prefix: WP
Page: G-18	Page: G-19	Page: G-20	Page: G-21



Wear Plates (Bronze)	L-Gibs (Bronze)	Angle Pins	Angle Pin Holders
Prefix: WP	Prefix: LGIB	Prefix: AP	Prefix: APH
Page: G-22	Page: G-22	Page: G-23	Page: G-24 & G-25



CAM ACTION® ASSEMBLIES SELECTION GUIDE

Progressive's CamActions provide easy installation for molding and releasing details. Several sizes and travel configurations are available.

- Advanced materials and treatments for long-lasting production.
- Inserts and pins available in all series.
- For application assistance, please contact tech@procomps.com.



Inch Standard

TRAVEL	OVERALL ASSEMBLY SIZES	CATALOG NUMBER	CAMACTION SERIES	PAGE NUMBER
.160"	1.00" X 1.25" X 1.00" H	CA-100	100 Series	G-2
.230"	1.00" X 1.25" X 1.50" H	CA-200	200 Series	G-3
.230"	1.00" X 1.25" X 4.12" H	CA-200L*		
.150"	.50" X .75" X 1.25" H	CA-250-15	250 Series	G-4
.310"	.80" X 1.38" X 1.75" H	CA-250-31		
.500"	1.25" X 2.00" X 2.75" H	CA-250-50	300 Series	G-5
.250"	1.50" X 2.25" X 2.25" H	CA-300		
.250"	1.50" X 2.25" X 5.79" H	CA-300L*	350 Series	G-7
.750"	1.50" X 2.63" X 2.63" H	CA-350		
1.000"	3.00" X 4.00" X 4.44" H	CA-400	400 Series	G-9

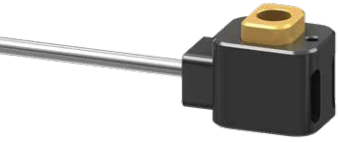
L= Longer Driver or Lock to extend below parting line.

Metric Standard

TRAVEL	OVERALL ASSEMBLY SIZES	CATALOG NUMBER	CAMACTION SERIES	PAGE NUMBER
4mm	26 X 32 X 25.4 H	CAMM-100	100 Series	G-2
5.8mm	26 X 32 X 38.1 H	CAMM-200	200 Series	G-3
5.8mm	26 X 32 X 103.2 H	CAMM-200L*		
4mm	12 X 20 X 32 H	CAMM-250-4	250 Series	G-4
8mm	20 X 34 X 47 H	CAMM-250-8		
12mm	32 X 50 X 68 H	CAMM-250-12	300 Series	G-6
6.35mm	40 X 60 X 57.7 H	CAMM-300		
6.35mm	40 X 60 X 147.4 H	CAMM-300L*	350 Series	G-8
18mm	40 X 64 X 66.5 H	CAMM-350		

L= Longer Driver or Lock to extend below parting line.

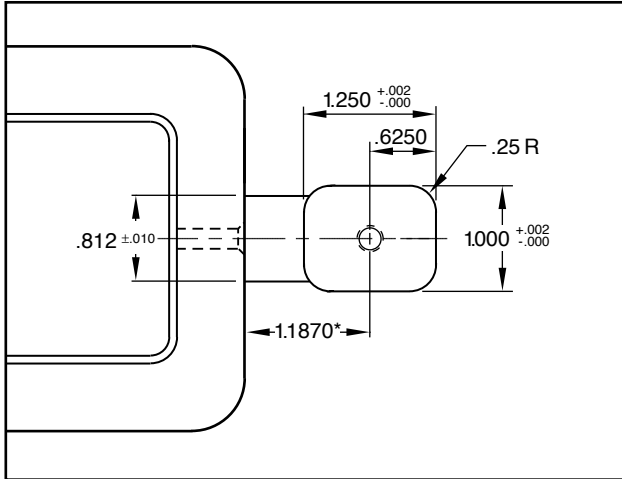
CAM ACTION®
100 SERIES



APPLICATION GUIDELINES

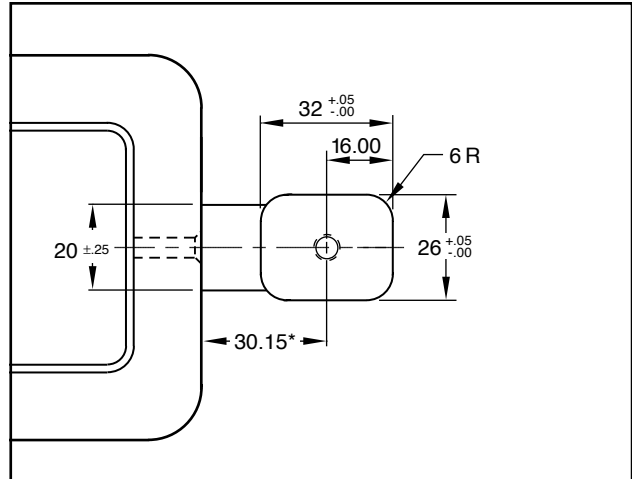
- Travel = .160" (4mm)
- Max operating temperature 300°F (150°C)
- Core Pins (sold on page G-10) are to be fully supported in the core as shown.

Inch Standard

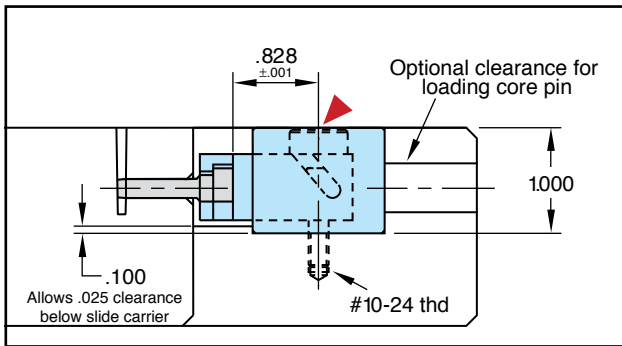


When the core pin is not shutting off on the inner core wall, the distance from the edge of the insert should be 1.142 for the slide carrier to shut off against the core insert.

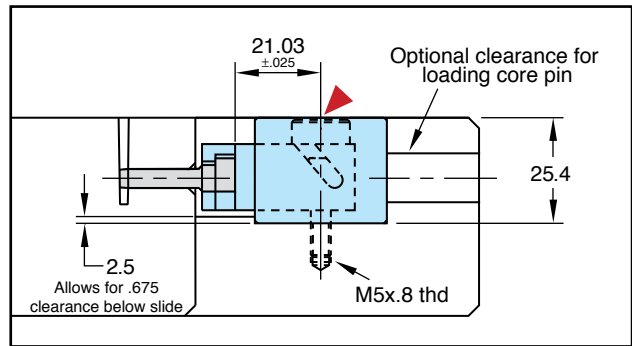
Metric Standard



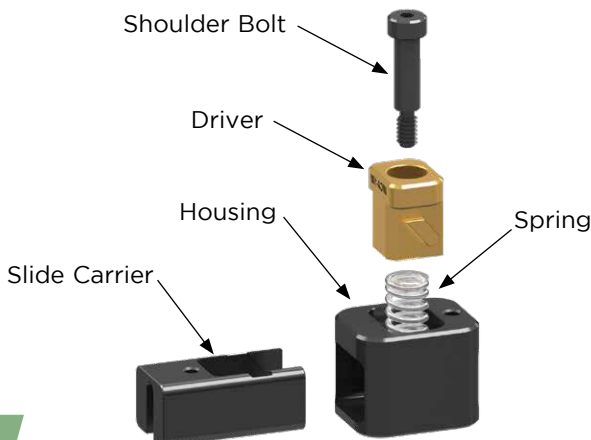
When the core pin is not shutting off on the inner core wall, the distance from the edge of the insert should be 29.00 for the slide carrier to shut off against the core insert.



The .828 dimension must be maintained to avoid improper spring pre-load or damage to internal components.



The 21.03 dimension must be maintained to avoid improper spring pre-load or damage to internal components.



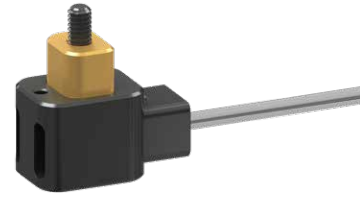
▶ CAD insertion point

CATALOG NUMBER	DESCRIPTION
CA-100	CamAction Unit
CAMM-100	Metric CamAction Unit

PART NAME	MATERIAL/TREATMENT
Driver	H-13, 40-44 HRC, Titanium Nitride
Slide Carrier	P-20, 30-34 HRC, Black Nitride
Housing	4140, 28-32 HRC, Black Nitride



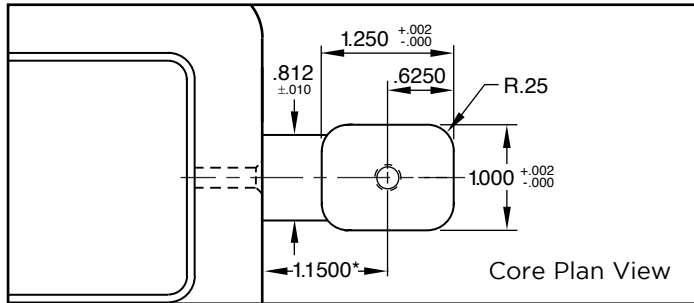
CAM ACTION® 200 SERIES



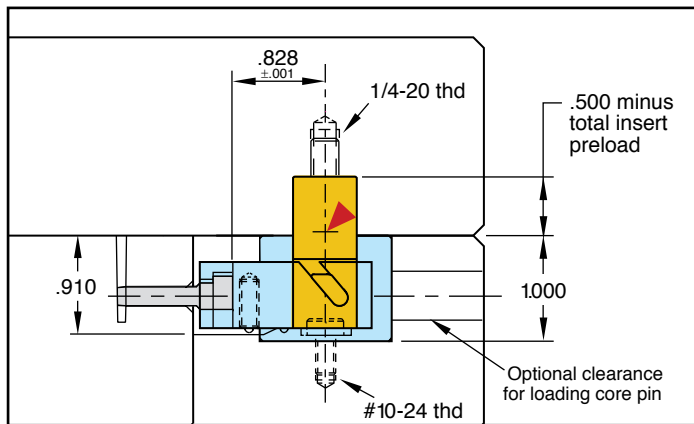
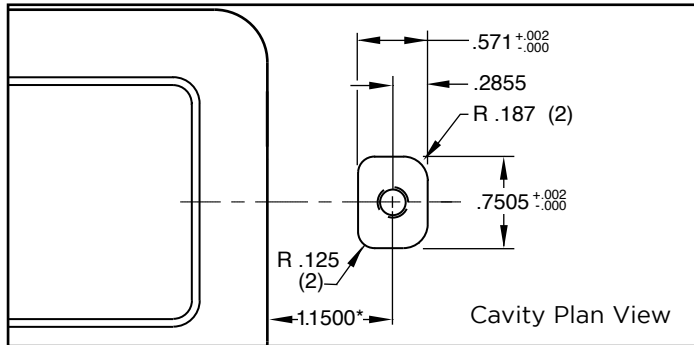
APPLICATION GUIDELINES

- Travel = .230" (5.8mm)
- Longer driver allows for extension below parting line up to 3" (76mm).
- Max operating temperature 480°F (250°C)
- Core Pins and Inserts (on page G-10) are to be fully supported in the core as shown.

Inch Standard

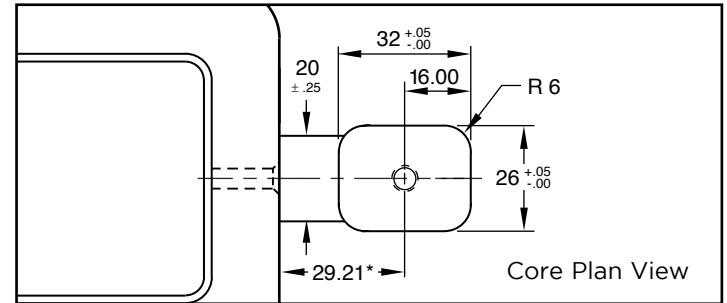


When the core pin is not shutting off on the inner core wall, the distance from the edge of the insert should be 1.1425 for the slide carrier to shut off against the core insert.

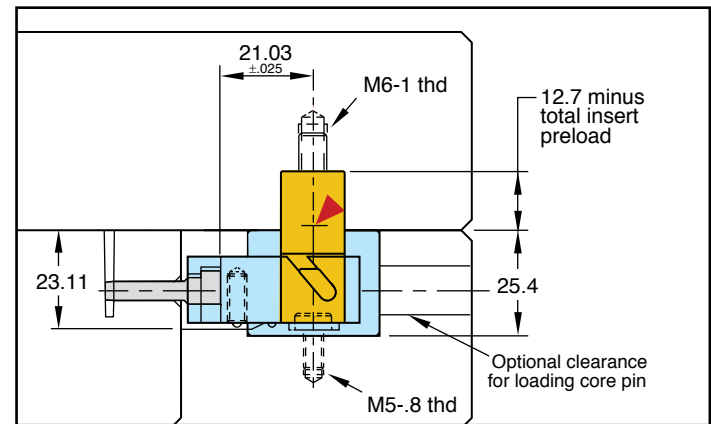
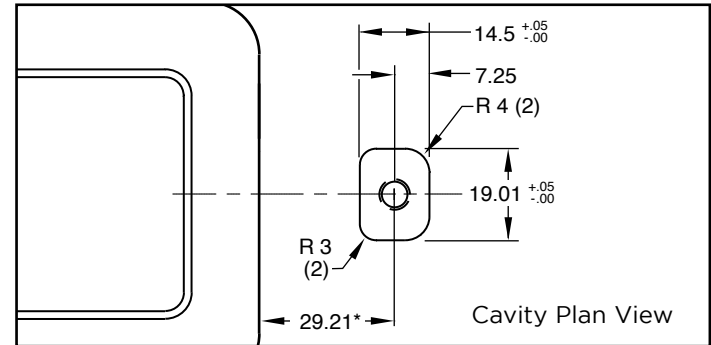


The .828 dimension must be maintained to ensure proper shut-off.

Metric Standard



When the core pin is not shutting off on the inner core wall, the distance from the edge of the insert should be 29.02 for the slide carrier to shut off against the core insert.

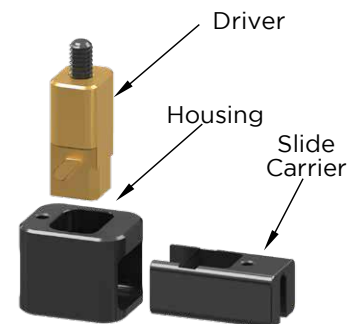


The 21.03 dimension must be maintained to ensure proper shut-off.

▶ CAD insertion point

CATALOG NUMBER	DESCRIPTION
CA-200	CamAction Unit-Standard Driver
CA-200L	CamAction Unit-Longer Driver
CAMM-200	Metric CamAction Unit-Standard Driver
CAMM-200L	Metric CamAction Unit-Longer Driver

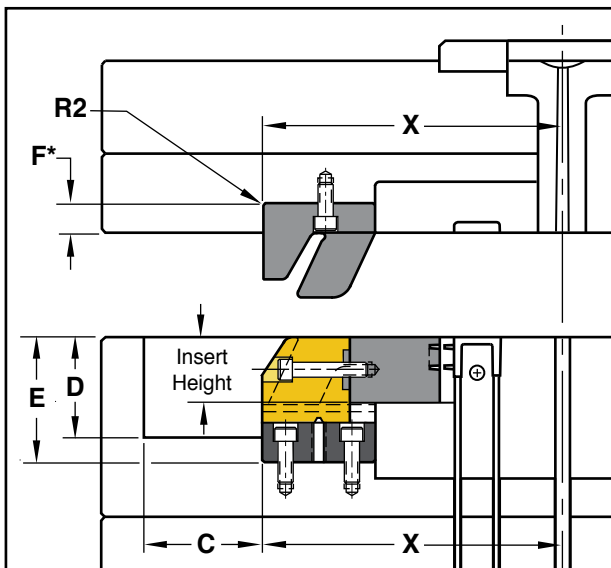
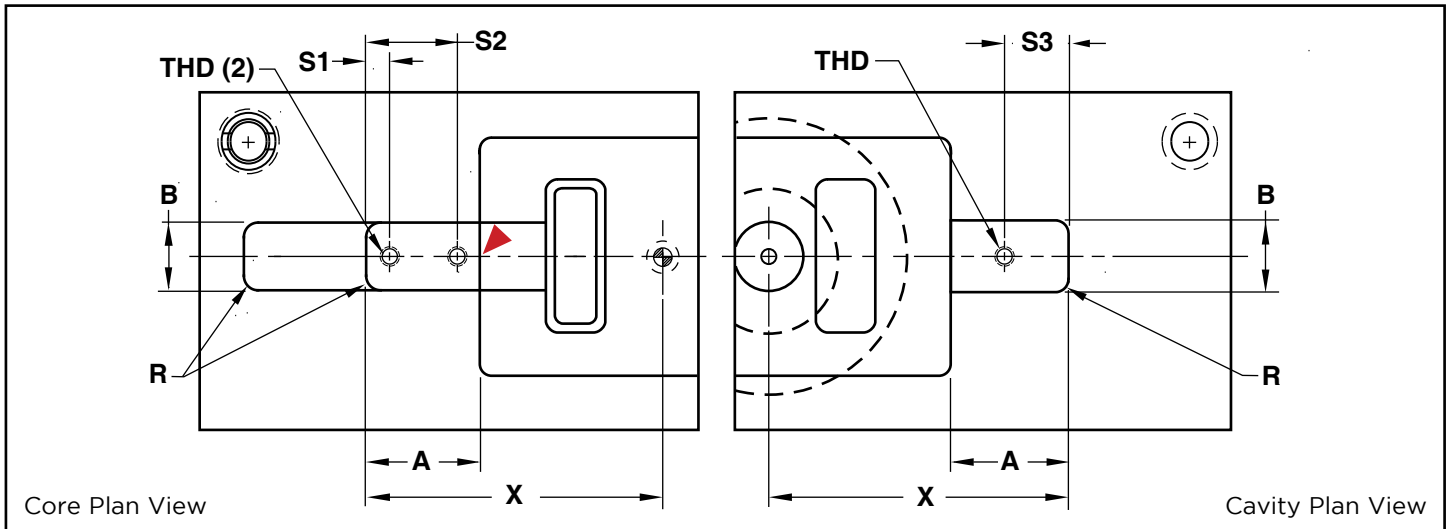
PART NAME	MATERIAL/TREATMENT
Driver	H-13, 40-44 HRC, Titanium Nitride
Slide Carrier	P-20, 30-34 HRC, Black Nitride
Housing	4140, 28-32 HRC, Black Nitride



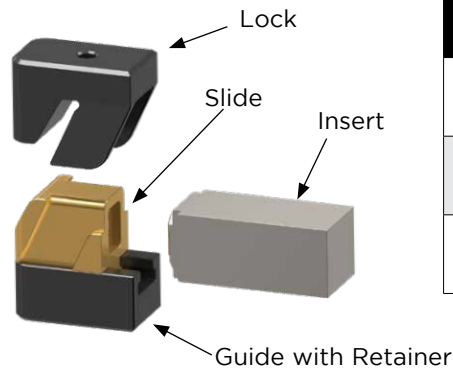
CAM ACTION®

250 SERIES

▶ CAD insertion point



*Minus pre-load.



PART NAME	MATERIAL/TREATMENT
Lock	H-13, 48-50 HRC, Black Nitride
Slide	H-13, 46-48 HRC, Titanium Nitride
Guide	H-13, 48-50 HRC, Black Nitride

APPLICATION GUIDELINES

- Machine pockets from the common location "X" to the dimensions shown.
- Slide Retainers (SRT-10/SRTM-04) are installed in the slides on the CA-250-50/CAMM-250-12. Ball Plungers retain the slide in the other sizes.
- Max operating temperature 480°F (250°C).
- Inserts are sold separately on page G-11.

Inch Standard

CATALOG NUMBER	TRAVEL	A	B	C MINIMUM CLEARANCE	D MINIMUM CLEARANCE	E	F	S1 ±.01	S2 ±.01	S3 ±.01	R	R2	THD
CA-250-15	.15	.750	.500	.63	.60	.937	.313	.15	.59	.43	1/8	.03	#4-40 x 3/8
CA-250-31	.31	1.375	.800	1.03	1.03	1.375	.375	.31	1.06	.75	3/16	.03	#8-32 x 7/16
CA-250-50	.50	2.000	1.250	1.50	1.90	2.125	.625	.37	1.62	1.12	1/4	.04	1/4-20 x 5/8

Socket Head Cap Screws (3) included.

Metric Standard

CATALOG NUMBER	TRAVEL	A	B	C MINIMUM CLEARANCE	D MINIMUM CLEARANCE	E	F	S1 ±.25	S2 ±.25	S3 ±.25	R	R2	THD
CAMM-250-4	4	20	12	17	16	24	8	4	16	10	3	.4	M3-.5 x 10
CAMM-250-8	8	34	20	27	27	38	9	7	27	19	4	.4	M4-.7 x 12
CAMM-250-12	12	50	32	39	38	53	15	10	40	27	5	1.0	M6-1 x 18

Socket Head Cap Screws (3) included.

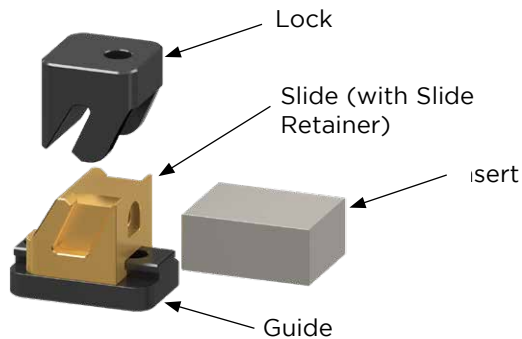
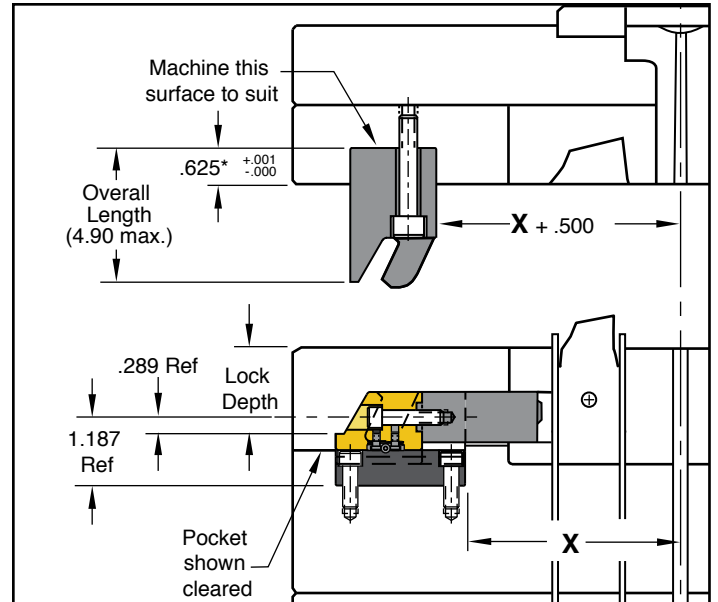
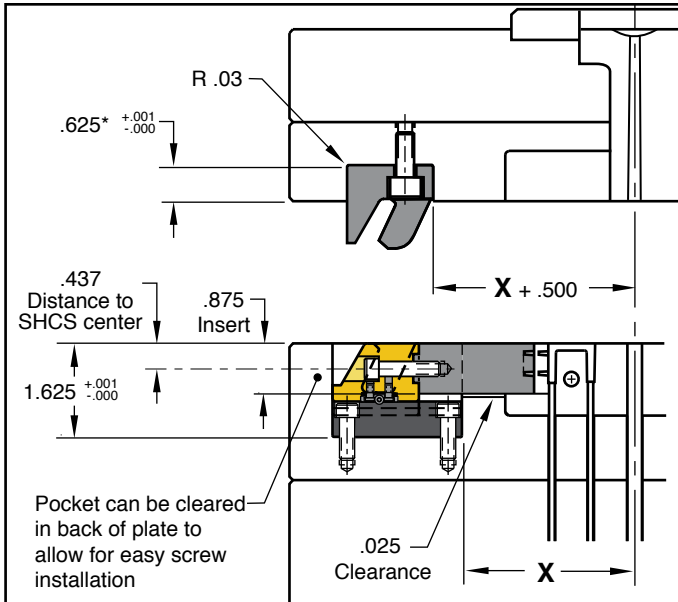
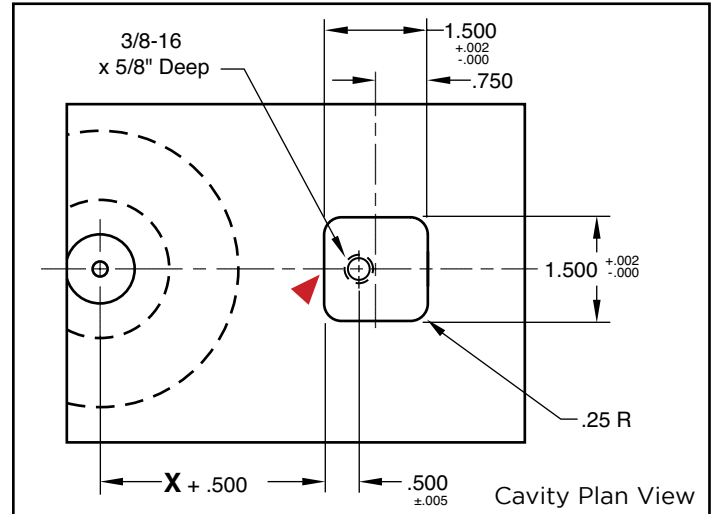
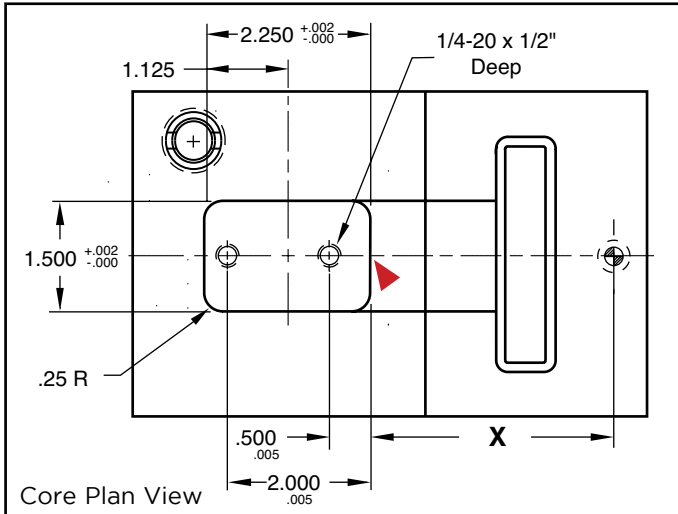


CAM ACTION® 300 SERIES: INCH STANDARD



APPLICATION GUIDELINES

- Travel = .250"
- Each assembly includes SRT-10 Slide Retainer and (3) mounting screws.
- Max operating temperature 425°F (220°C).
- Core Pins and Inserts are sold separately on page G-12.

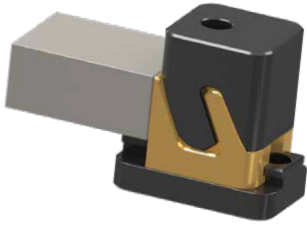


▶ CAD insertion point

CATALOG NUMBER	DESCRIPTION
CA-300	CamAction Unit-Standard Lock
CA-300L	CamAction Unit-Longer Lock
PART NAME	MATERIAL/TREATMENT
Lock	H-13, 40-44 HRC, Black Nitride
Slide	H-13, 40-44 HRC, Titanium Nitride
Guide	4140, 28-32 HRC, Black Nitride

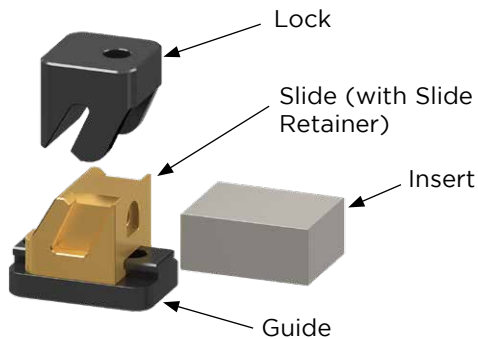
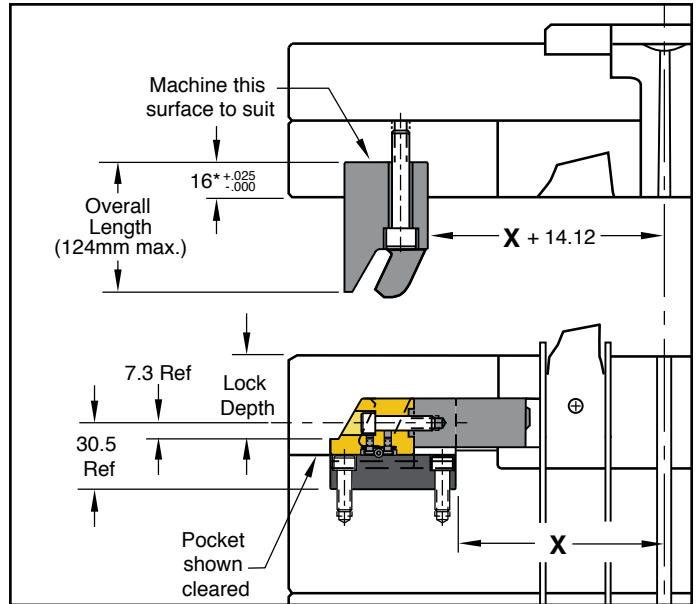
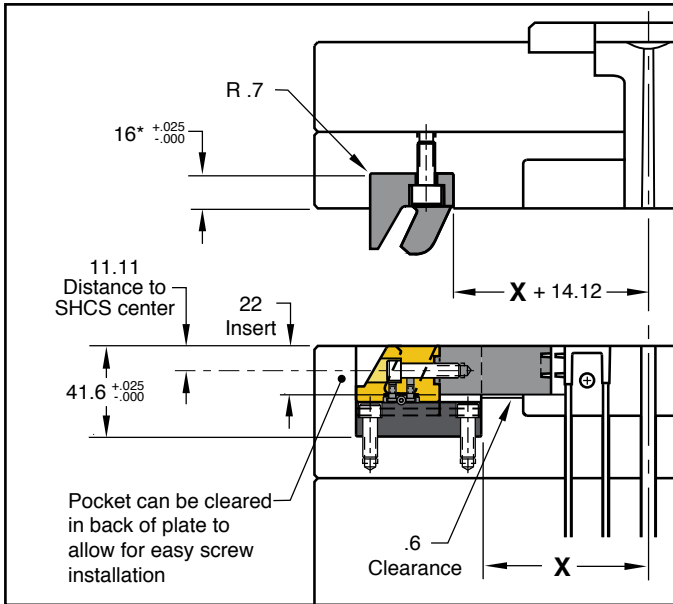
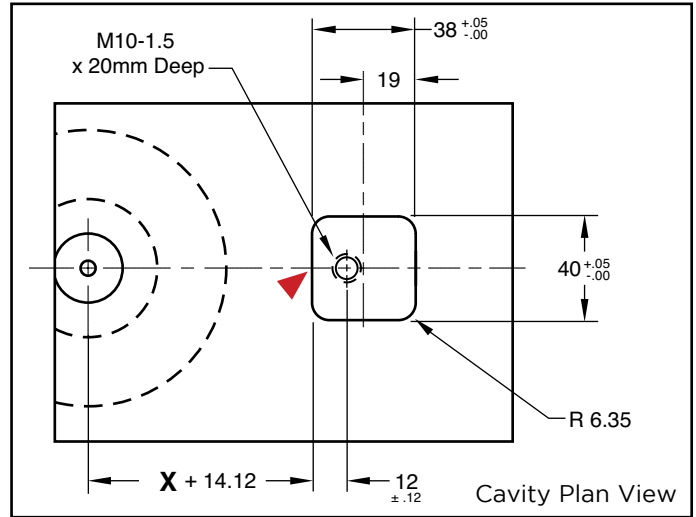
CAM ACTION®

300 SERIES: METRIC STANDARD



APPLICATION GUIDELINES

- Travel = 6.35mm
- Each assembly includes SRTM-04 Slide Retainer and (3) mounting screws. Core Pins and Inserts are sold separately on page G-12.
- Max operating temperature 425°F (220°C).
- See page G-5 for materials and treatments.

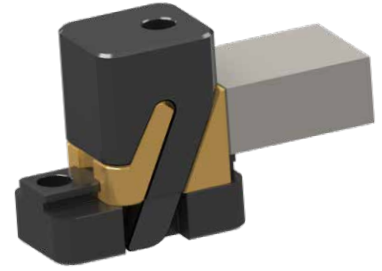


▶ CAD insertion point

CATALOG NUMBER	DESCRIPTION
CAMM-300	Metric CamAction Unit-Standard Lock
CAMM-300L	Metric CamAction Unit-Longer Lock

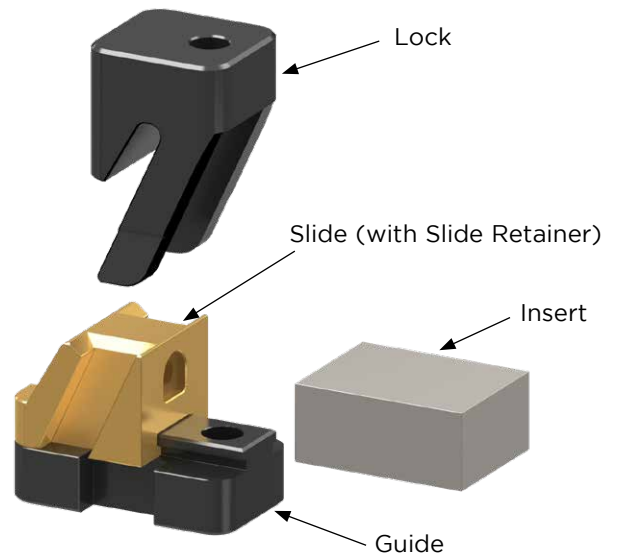
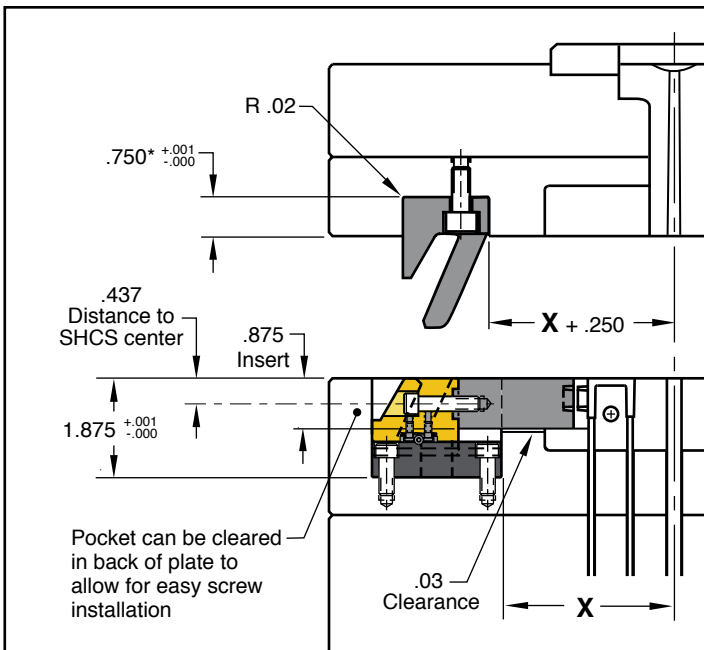
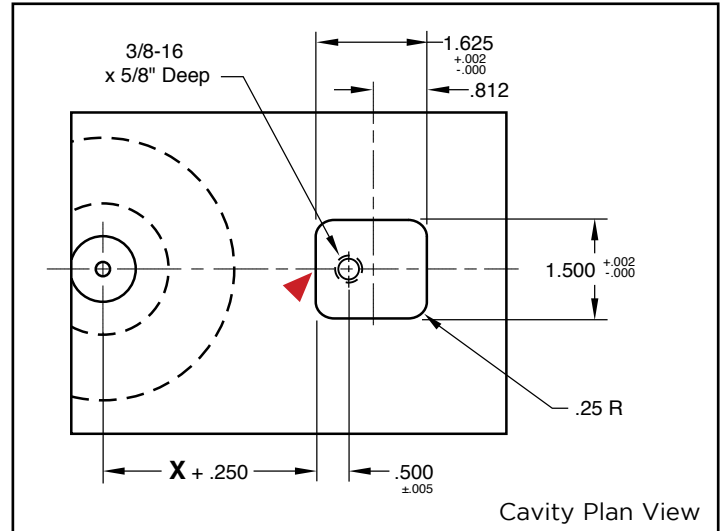
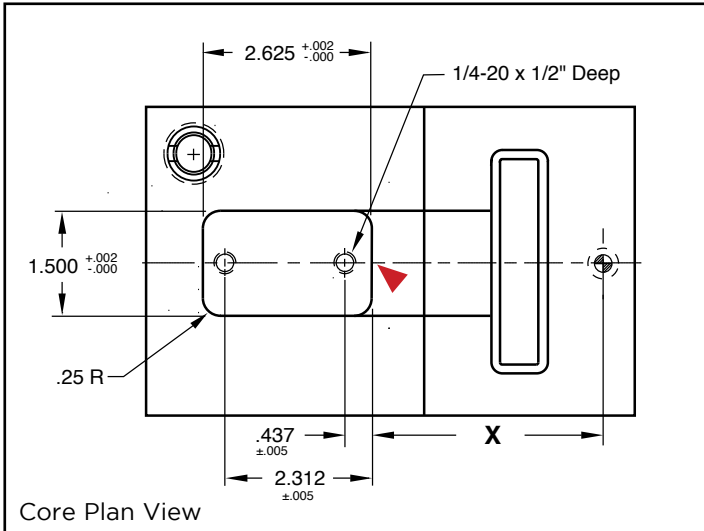


CAM ACTION® 350 SERIES: INCH STANDARD



APPLICATION GUIDELINES

- Travel = .750"
- Each assembly includes SRT-10 Slide Retainer and (3) mounting screws. Individual replacement parts are available.
- Max operating temperature 425°F (220°C).
- Core Pins and Inserts are sold separately on page G-12.

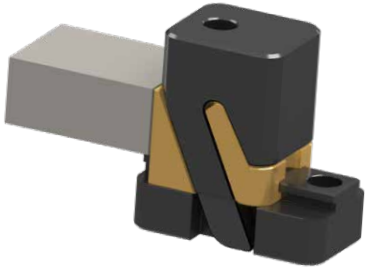


▶ CAD insertion point

PART NAME	MATERIAL/TREATMENT
Lock	H-13, 40-44 HRC, Black Nitride
Slide	H-13, 40-44 HRC, Titanium Nitride
Guide	4140, 28-32 HRC, Black Nitride

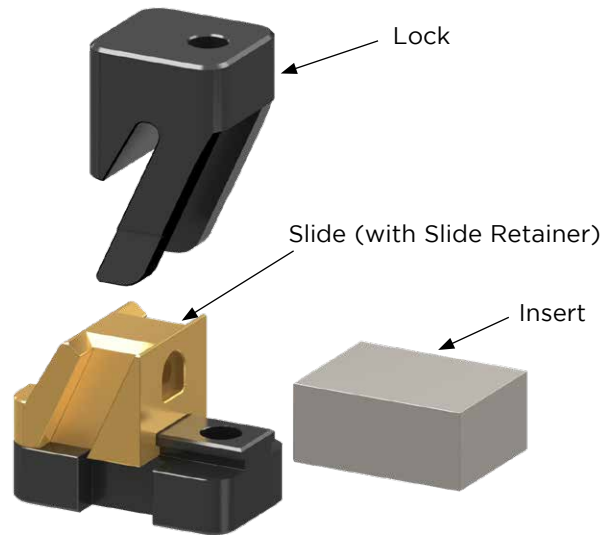
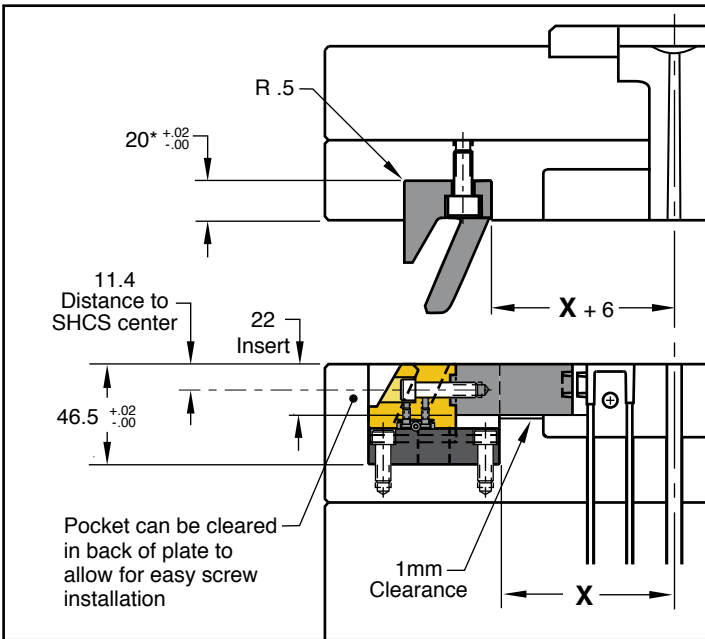
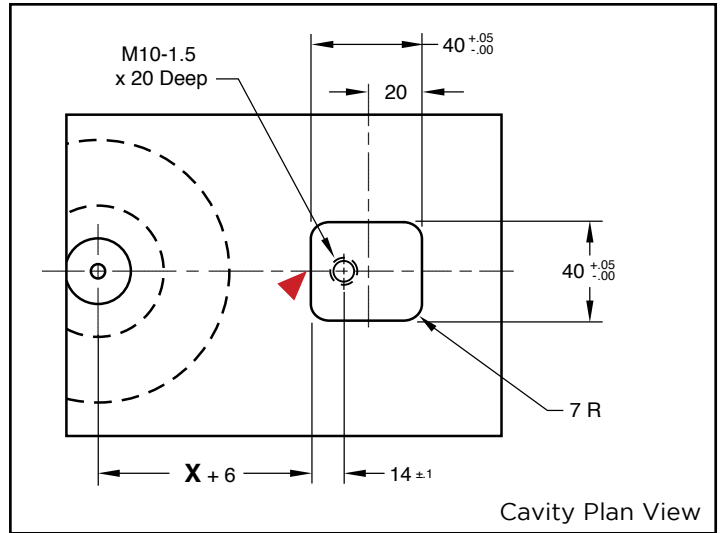
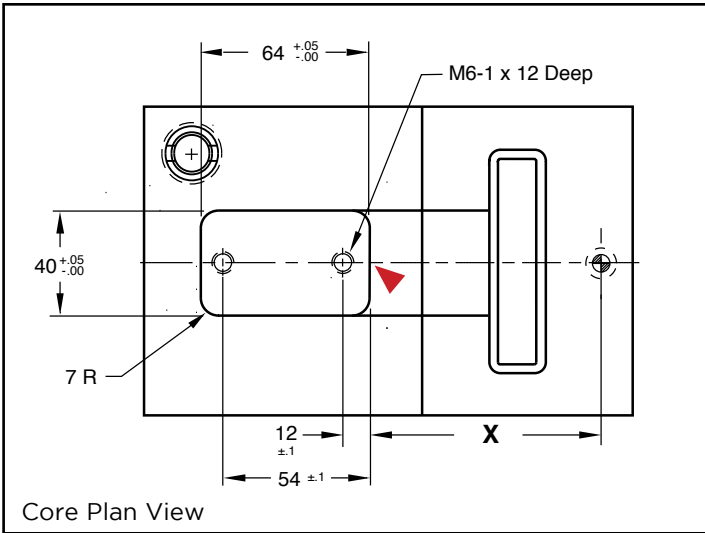
CATALOG NUMBER	DESCRIPTION
CA-350	CamAction Unit: 350 Series

CAM ACTION®
350 SERIES: METRIC STANDARD



APPLICATION GUIDELINES

- Travel = 18mm
- Each assembly includes SRTM-04 Slide Retainer and (3) mounting screws.
- Max operating temperature 425°F (220°C).
- Core Pins and Inserts are sold separately on page G-12.



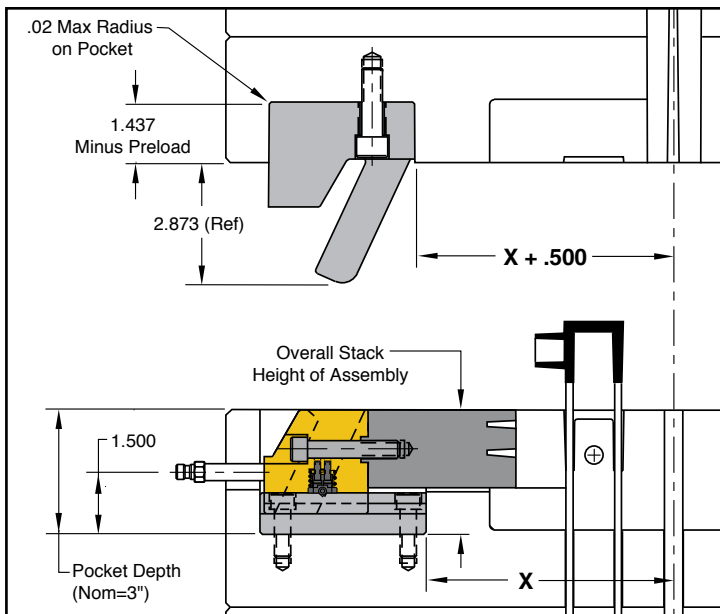
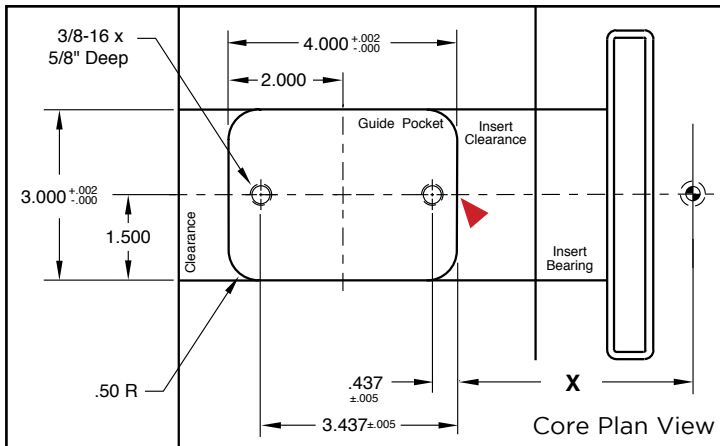
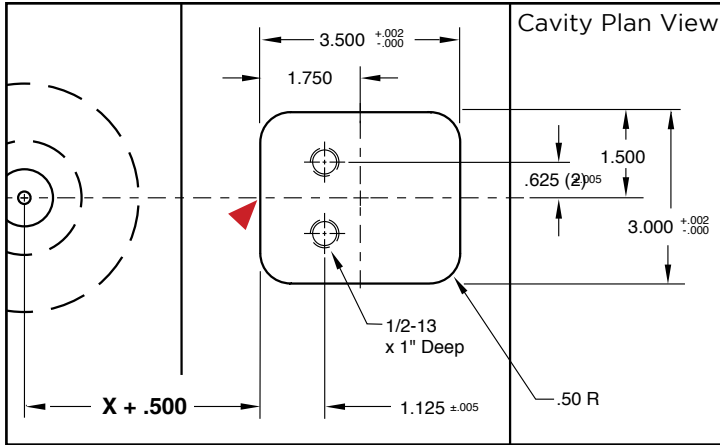
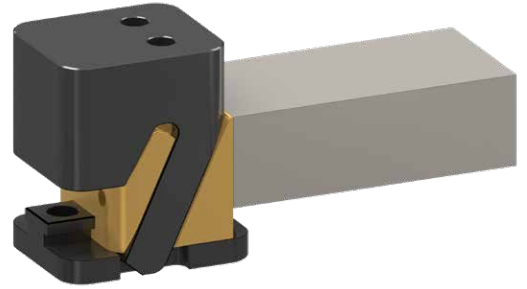
▶ CAD insertion point

PART NAME	MATERIAL/TREATMENT
Lock	H-13, 40-44 HRC, Black Nitride
Slide	H-13, 40-44 HRC, Titanium Nitride
Guide	4140, 28-32 HRC, Black Nitride

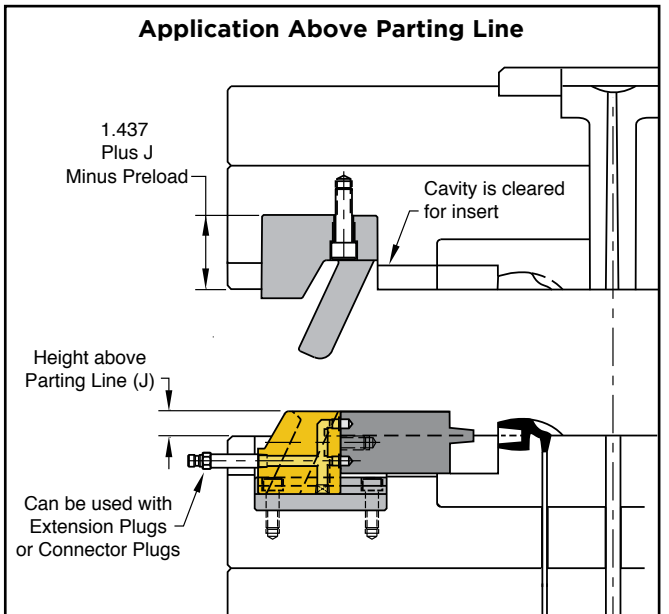
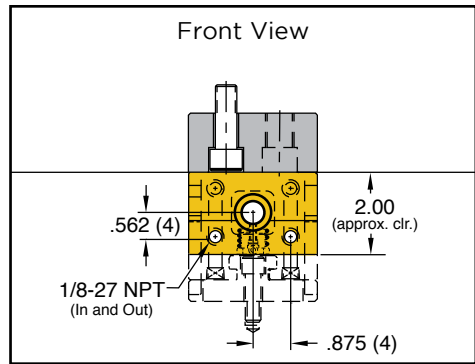
CATALOG NUMBER	DESCRIPTION
CAMM-350	CamAction Unit: 350 Series (Metric)



CAM ACTION® 400 SERIES: INCH STANDARD



- ### APPLICATION GUIDELINES
- Travel = 1.00"
 - Max operating temperature 425°F (220°C).
 - Each assembly includes an installed SRT-30 Slide Retainer, Threadless Waterline Plugs (2), O-Rings (2), and (4) mounting screws.
 - Inserts are sold separately on page G-13.



▶ CAD insertion point

PART NAME	MATERIAL/TREATMENT
Lock	H-13, 40-44 HRC, Black Nitride
Slide	H-13, 40-44 HRC, Titanium Nitride
Guide	4140, 28-32 HRC, Black Nitride

CATALOG NUMBER	DESCRIPTION
CA-400	CamAction Unit with 1" Travel

US Patent Nos. 7,229,269 & 7,431,581, with other patents issued and pending.

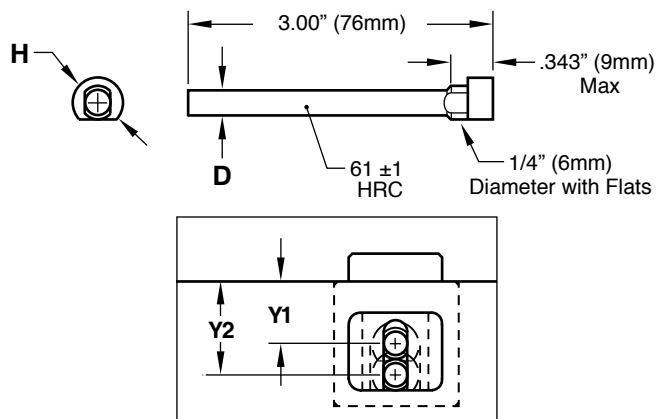
CAM ACTION ACCESSORIES

100/200 SERIES CORE PINS



M M-2 **H** 60-62 HRC **S** Chrome Plated

CATALOG NUMBER	D	H	Y1	Y2
CAP1-187	.1872 .1869	.37	.500	.750
CAP1-375	.3747 .3744	.37	.500	.688
CAPMM-5	4.984mm 4.992mm	9.5mm	12.7mm	19.05mm
CAPMM-10	9.985mm 9.992mm	9.5mm	12.7mm	17.40mm



APPLICATION GUIDELINES

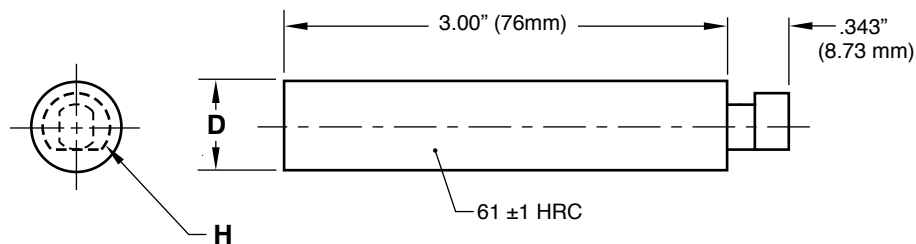
- For use with 100 and 200 Series CamActions.
- When using with the 100 Series, 2° draft per side (minimum) is required in the molding area.
- Core Pin range shown above. Pins are keyed to fit into slot on slide carrier.

200 SERIES CORE PINS



M M-2 **H** 60-62 HRC **S** Chrome Plated

CATALOG NUMBER	D	H
CAP2-500	.5001 .5003	.37
CAP2MM-13	13.002mm 13.007mm	9.5mm



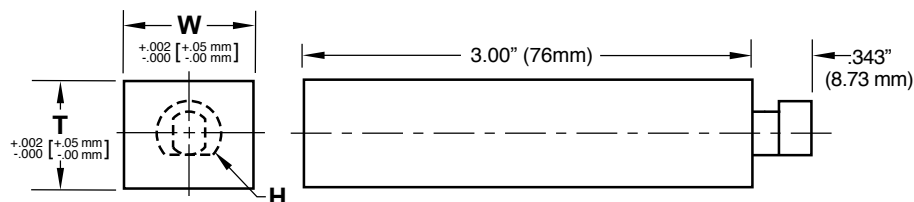
For use with 200 Series CamActions only.

200 SERIES INSERTS



M P-20 Pre-Hard **S** Black Nitride

CATALOG NUMBER	T	W	H
CSE2-62X75	.625	.750	.37
CSE2MM-16X19	15.98mm	19mm	9.5mm

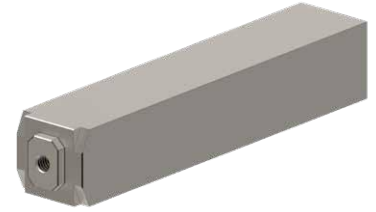
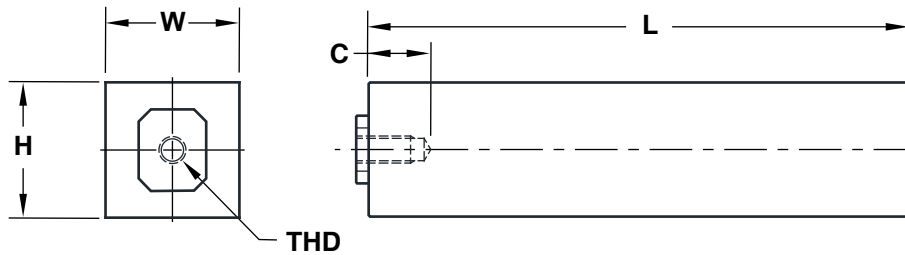


For use with 200 Series CamActions only.



CAM ACTION ACCESSORIES

250 SERIES INSERTS



M DC53 / 1.2360 **H** 58-62 HRC
M H-13 / 1.2343 **H** 48-52 HRC

Inch Standard

ASSEMBLY CATALOG NUMBER	DC53 / 1.2360 CATALOG NUMBER	H-13 / 1.2343 CATALOG NUMBER	W +.000 -.001	H +.000 -.001	L	C	THD
CA-250-15	CSE25P-15L2	CSE25H-15L2	.500	.374	2.250	3/8	#4-40 x 1/2
CA-250-31	CSE25P-31L2.5	CSE25H-31L2.5	.800	.749	2.500	1/2	#8-32 x 7/8
CA-250-50	CSE25P-50L4	CSE25H-50L4	1.250	1.249	4.000	3/4	1/4-20 x 1-1/4

Socket Head Cap Screw included.

M DC53 / 1.2360 **H** 58-62 HRC
M H-13 / 1.2343 **H** 48-52 HRC

Metric Standard

ASSEMBLY CATALOG NUMBER	DC53 / 1.2360 CATALOG NUMBER	H-13 / 1.2343 CATALOG NUMBER	W +.00 -.03	H +.00 -.03	L	C	THD
CAMM-250-4	CSE25MMP-4L60	CSE25MMH-4L60	12	10	60	8	M3 -.5 x 12
CAMM-250-8	CSE25MMP-8L80	CSE25MMH-8L80	20	20	80	11	M4 -.7 x 22
CAMM-250-12	CSE25MMP-12L100	CSE25MMH-12L100	32	29	100	15	M5-.8 x 30

Socket Head Cap Screw included.



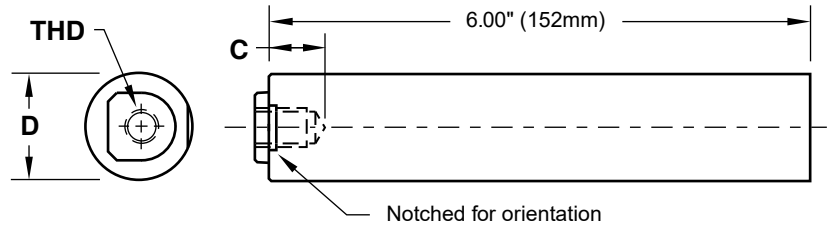
CAM ACTION ACCESSORIES

300/350 SERIES CORE PINS



M M-2 **H** 58-62 HRC **S** Chrome Plated

CATALOG NUMBER	D	THD	C
CAP3-750	.7504 .7508	1/4-20 x 7/8	3/4
CAP3MM-19	19.009mm 19.019mm	M6-1 x 20	20mm



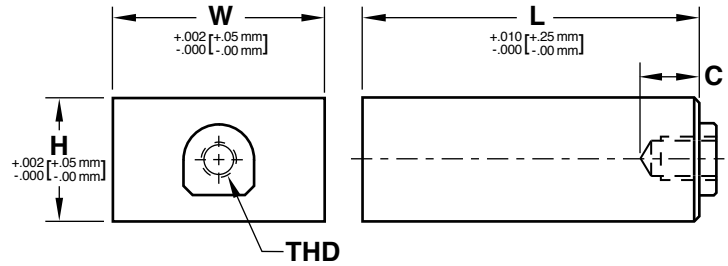
Socket Head Cap Screw included.

300 SERIES INSERTS



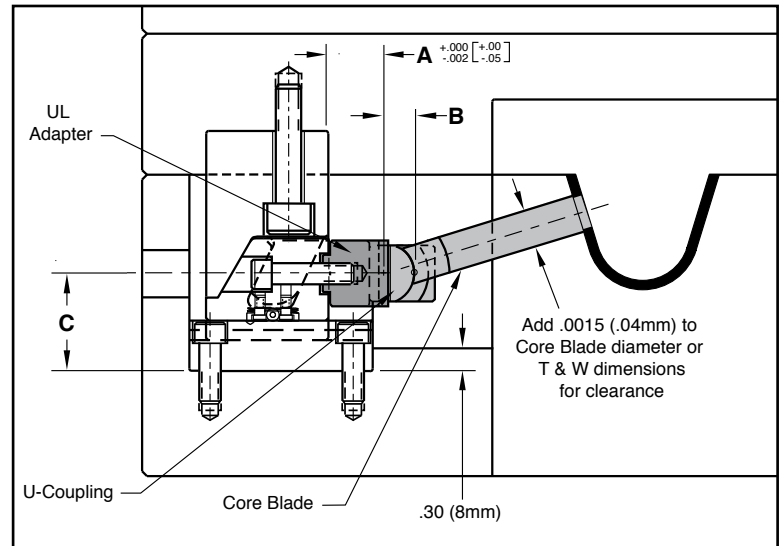
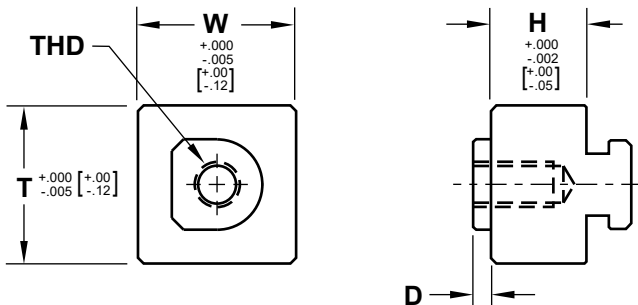
M P-20 Pre-Hard **S** Salt Bath Nitride

CATALOG NUMBER	H	W	L	THD	C
CSE3-50	.875	1.500	.50	1/4-20 x 7/8	5/8
CSE3-200	.875	1.500	2.00	1/4-20 x 7/8	5/8
CSE3MM-12	22mm	38mm	12mm	M6-1 x 20	15mm
CSE3MM-50	22mm	38mm	50mm	M6-1 x 20	15mm



Socket Head Cap Screw included.

300 SERIES UL ADAPTERS



M 4140 **S** Salt Bath Nitride

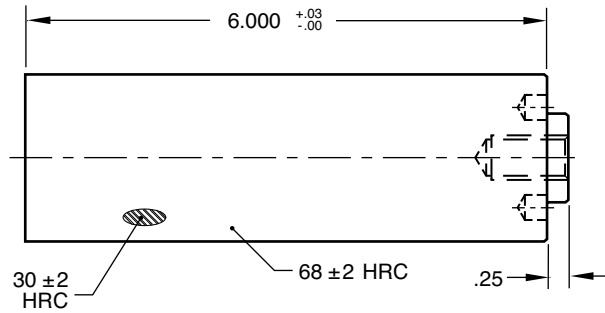
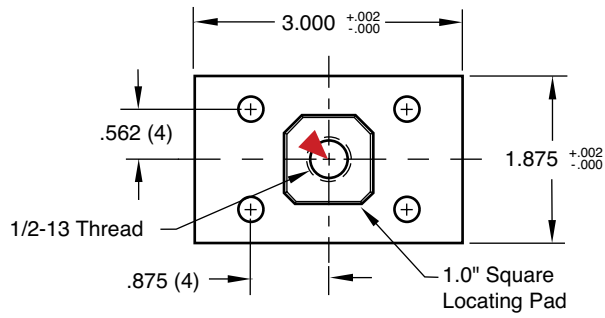
CATALOG NUMBER	T	W	H	D	THD	A	B	C	COMPATIBLE U-COUPLING
CTG-300	.875	.875	.563	.098	1/4-20 x 7/8	.75	.406	1.187	UCU87
CTGMM-300	23 mm	23 mm	6 mm	2.5 mm	M6-1 x 22	12 mm	10 mm	30.15 mm	UCMM22

Socket Head Cap Screw included. UniLifter Core Blades and U-Couplings are sold in section H.



CAM ACTION ACCESSORIES

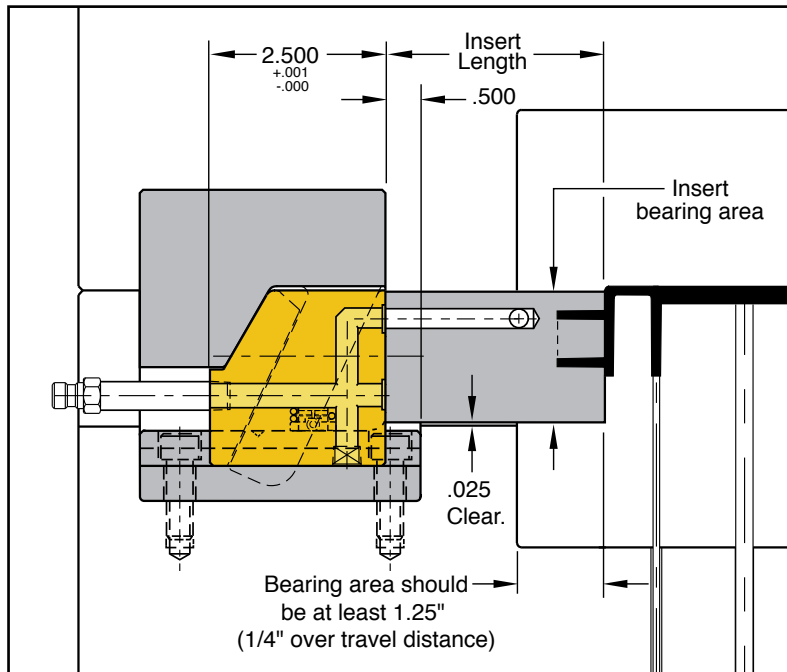
400 SERIES INSERTS



M P-20 Pre-Hard **S** Salt Bath Nitride (SBN)

CATALOG NUMBER	DESCRIPTION
CSE4-18X30	CA-400 Insert

1/2-13 x 1-3/4 Socket Head Cap Screw included.



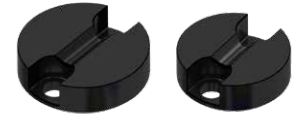
▶ CAD insertion point

SLIDE RETAINERS



Progressive's SRT® Series Slide Retainers reliably hold from 2 to 80 pounds (1 to 36 kgs) each. This slide retention design now features color-coded springs to indicate force rating. This compact design allows for installation in a mold base or wear plates.

Optional cleats may be selected or the V-Groove for roller retention may be machined in the bottom of the slide as shown on page G-15.



Inch Standard

Roller: **M** M-2 **H** 60-62 HRC **S** Titanium Nitride Coated 80 HRC

M 4140 **H** 50-54 HRC **S** Black Oxide

SLIDE RETAINERS								CLEATS				
SLIDE RETAINER CATALOG NUMBER	MAX WEIGHT PER UNIT (LBS)	D +.005 -.000	L ±.001	S ±.002	T SCREWS (2)	E MINIMUM THREAD DEPTH	SPRING COLOR	CLEAT CATALOG NUMBER	G ±.001	C ±.002	H SCREWS (2)	J MINIMUM THREAD DEPTH
SRT-02	2	.625	.160	.155	#4-48	.075	GRN	SRTC-10	.250	.190	#6-32	.250
SRT-04	4						BLU					
SRT-10	10						RED					
SRT-20	20	.750	.500	.150	#8-32	.190	GRN	SRTC-30	.250	.250	#6-32	.250
SRT-30	30						BLU					
SRT-50	50	.875	.750	.150	#8-32	.245	RED	SRTC-80	.250	.300	#6-32	.250
SRT-80	80						YEL					
SRT-40	40						BLU					
SRT-60	60	1.125	.856	.205	1/4-20	.480	RED	SRTC-75	.250	.400	#6-32	.250
SRT-75	75						YEL					

Cleats sold separately.

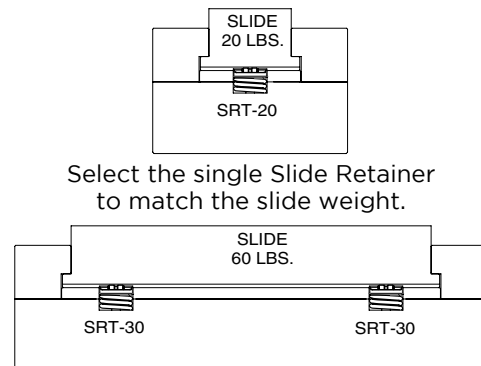
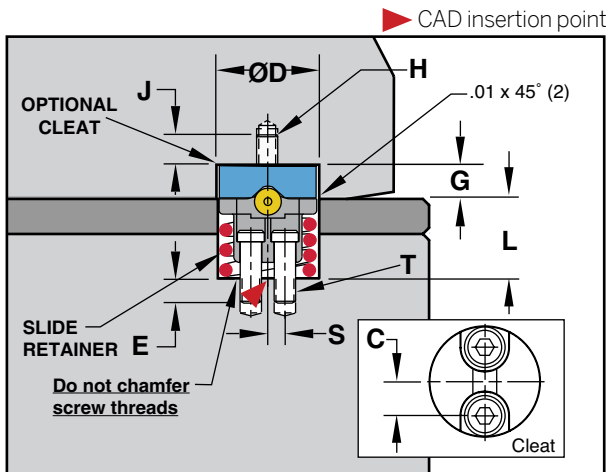
Metric Standard

Roller: **M** M-2 **H** 60-62 HRC **S** Titanium Nitride Coated 80 HRC

M 4140 **H** 50-54 HRC **S** Black Oxide

SLIDE RETAINERS								CLEATS				
SLIDE RETAINER CATALOG NUMBER	MAX WEIGHT PER UNIT (LBS)	D +1 -0	L ±.025	S ±.05	T SCREWS (2)	E MINIMUM THREAD DEPTH	SPRING COLOR	CLEAT CATALOG NUMBER	G ±.025	C ±.05	H SCREWS (2)	J MINIMUM THREAD DEPTH
SRTM-01	1	15.9	4.06	3.95	M3 - .5	1.9	GRN	SRTMC-04	6.35	4.85	M3 - .5	6.35
SRTM-02	2						BLU					
SRTM-04	4						RED					
SRTM-09	9	19.1	12.70	3.80	M4 - .7	4.8	GRN	SRTMC-13	6.35	6.35	M3 - .5	6.35
SRTM-13	13						BLU					
SRTM-22	22	22.3	19.05	3.80	M4 - .7	6.2	RED	SRTMC-36	6.35	7.60	M3 - .5	6.35
SRTM-36	36						YEL					
SRTM-18	18	28.2	21.75	5.20	M6 - 1.0	12.0	BLU	SRTMC-34	6.35	10.50	M3 - .5	6.35
SRTM-28	28						RED					
SRTM-34	34						YEL					

Cleats sold separately.



Select the single Slide Retainer to match the slide weight.

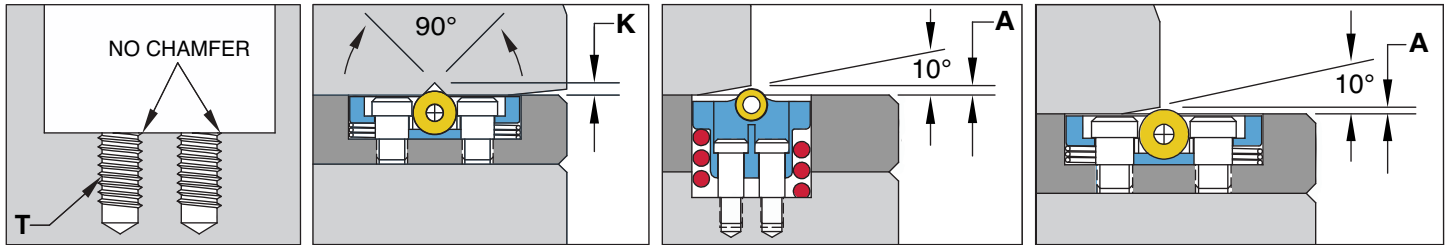
Or add the force of multiple Slide Retainers to match the slide weight.



SLIDE RETAINERS

APPLICATION GUIDELINES

- Maximum operating temperature is 425°F (220°C).
- Match total Slide Retainers Spring force to slide weight; excess spring force could induce wear.
- Do not chamfer screw threads.
- Machine 10° lead-in on all slides to aid in assembly once the SRT is installed.
- Optional Bases and Bushings shown on the following page allow for installation in plates made from materials such as aluminum, copper, and bronze and contain the screw/thread installation.



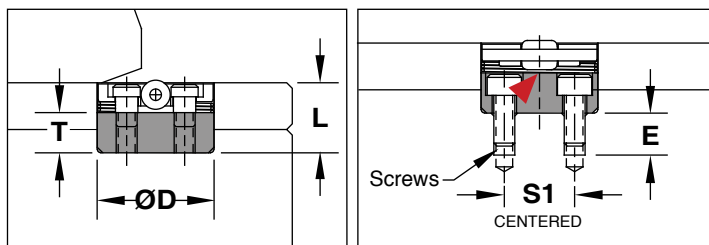
RETAINER CATALOG NUMBER	T THREAD (2)	TAP CLASS REQUIRED	K V-GROOVE	A 10° ANGLE LEAD - IN
SRT-02	#4-48	2B GH2	.041"	.02"
SRT-04				
SRT-10				
SRT-20				
SRT-30	#8-32	2B GH3	.078"	.04"
SRT-50				
SRT-80	1/4-20	2B GH3	.102"	.07"
SRT-40				
SRT-60				
SRT-75				
SRTM-01	M3 - .5	6H D3	1 mm	.50 mm
SRTM-02				
SRTM-04				
SRTM-09				
SRTM-13	M4 - .7	6H D4	2 mm	1.00 mm
SRTM-22				
SRTM-36	M4 - .7	6H D4	2 mm	1.27 mm
SRTM-18				
SRTM-28				
SRTM-34				



SLIDE RETAINERS BASES & BUSHINGS

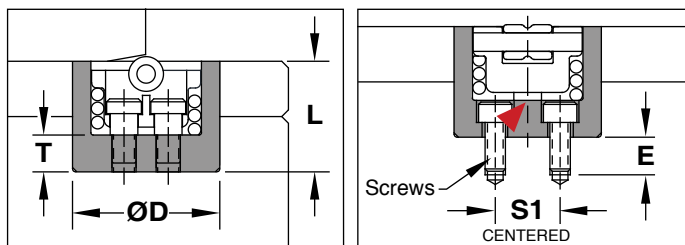


SRT BASES



SRT Bases enable the Slide Retainer to be installed in a hardened plate when mold base steel is aluminum, for example. (SRTBA-10 shown in graphics.)

SRT BUSHINGS



SRT Bushings accept the standard Slide Retainer to allow for installation in soft materials (aluminum, copper bronze, etc). Also, the SRT Bushing can provide hardened guidance against wear rather than bearing on a bronze wear plate. (SRTBU-30 shown in graphics.)

Inch Standard

Base: **M** D-2 **H** 58-60 HRC **S** Black Oxide

Bushing: **M** D-2 **H** 58-60 HRC **S** Black Oxide

CATALOG NUMBER	D +.005 -.000	L ±.001	S1 ±.01	T	E REF	SCREWS (2)	USE WITH	CATALOG NUMBER	D +.001 -.000	L +.002 -.000	S1 ±.01	T	E REF	SCREWS (2)
SRTBA-10	.625	.375	.37	.215	.220	#4-40 x 5/16	SRT-02	SRTBU-10	.875	.375	.37	.215	.220	#4-40 x 5/16
							SRT-04							
							SRT-10							
SRTBA-30	.750	.750	.44	.250	.280	#6-32 x 3/8	SRT-20	SRTBU-30	1.000	.750	.44	.250	.280	#6-32 x 3/8
							SRT-30							
SRTBA-80	.875	1.000	.50	.250	.280	#6-32 x 3/8	SRT-50	SRTBU-80	1.125	1.000	.50	.250	.280	#6-32 x 3/8
SRTBA-75	1.125	1.300	.62	.443	.380	#10-32 x 1/2	SRT-40	SRTBU-75	1.500	1.300	.62	.443	.380	#10-32 x 1/2
							SRT-60							
							SRT-75							

Metric Standard

Base: **M** D-2 **H** 58-60 HRC **S** Black Oxide

Bushing: **M** D-2 **H** 58-60 HRC **S** Black Oxide

CATALOG NUMBER	D +.1 -.0	L ±.03	S1 ±.25	T	E REF	SCREWS (2)	USE WITH	CATALOG NUMBER	D +.03 -.00	L +.05 -.00	S1 ±.25	T	E REF	SCREWS (2)
SRTMBA-04	15.9	9.56	8	5.50	5.30	M2.5-.45 x 8	SRTM-01	SRTMBU-04	22.3	9.50	8	5.44	5.35	M2.5-.45 x 8
							SRTM-02							
							SRTM-04							
SRTMBA-13	19.1	19.05	11	6.35	4.95	M3-.5 x 8	SRTM-09	SRTMBU-13	25.4	19.10	11	6.35	4.95	M3-.5 x 8
							SRTM-13							
SRTMBA-36	22.3	25.40	13	6.35	4.95	M3-.5 x 8	SRTM-22	SRTMBU-36	28.5	25.40	13	6.35	4.95	M3-.5 x 8
SRTMBA-34	28.2	33.00	16	11.25	9.90	M5-.8 x 12	SRTM-18	SRTMBU-34	37.0	33.00	16	11.25	9.90	M5-.8 x 12
							SRTM-28							
							SRTM-34							

► CAD insertion point

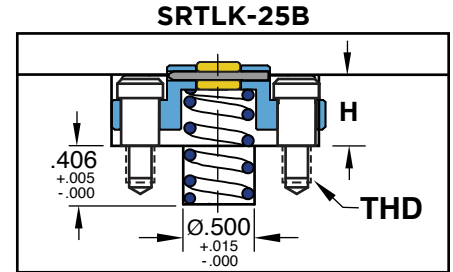
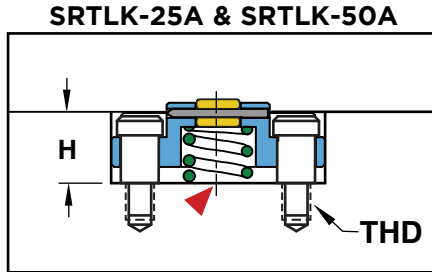
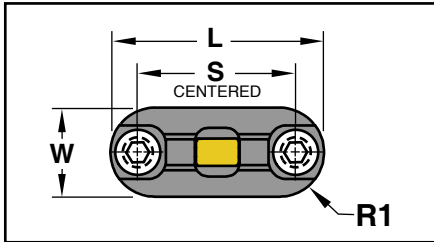


SLIDE RETAINERS

SLIDE LOCK STYLE

Slide Lock Style slide retention is offered in sizes compatible with previous standards, and Progressive's now provides smooth, greaseless friction-free performance.

Reliably holding 25 to 50 pounds each, this design features color-coded springs to indicate force rating.



Roller: **M** M-2 **H** 60-62 HRC **S** Titanium Nitride Coated 80 HRC

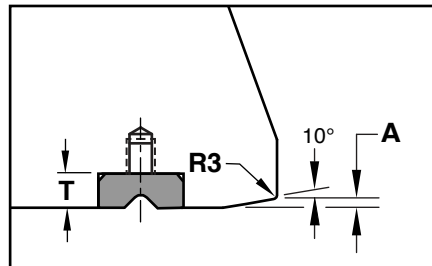
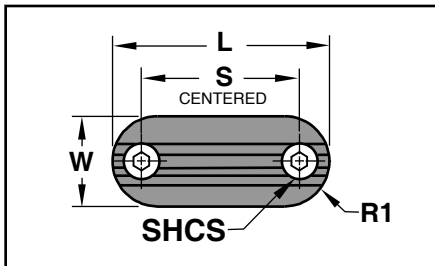
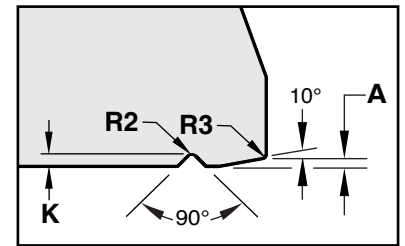
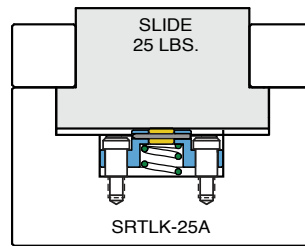
SLIDE RETAINER CATALOG NUMBER	MAX WEIGHT PER UNIT (LBS)	SPRING COLOR	L +.004 -.000	W +.004 -.000	H +.002 -.000	R1 +.002 -.000	THD	S	A	K	R2	R3
SRTLK-25A	25	GRN	1.500	.625	.500	.312	#6-32	1.100	.070	.100	.047	.03
SRTLK-25B	25	BLU										
SRTLK-50A	50	RED	2.300	1.000	.875	.500	1/4-20	1.650	.100	.155	.079	.05

▶ CAD insertion point

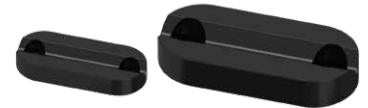
Pocket dimensions shown. Screws included.

APPLICATION GUIDELINES

- Select the single Slide Retainer to match the slide weight. Multiple retainers may be used for heavier slides.
- Machine the pockets as shown in the graphics and table.
- For retention on the slide, purchase the Cleats as shown below or machine the groove in the slide as shown at right.



CLEATS

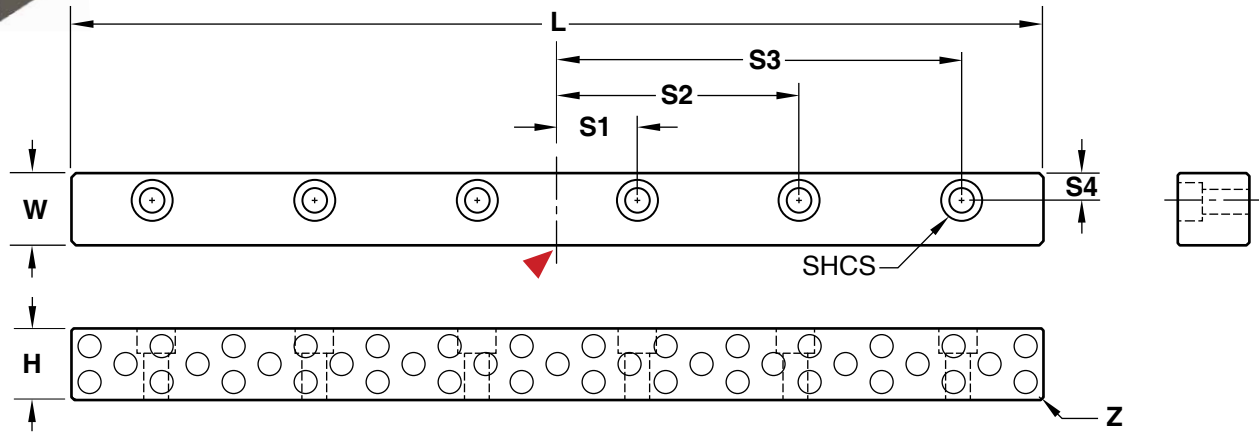


M 4140 **H** 50-54 HRC **S** Black Oxide

CLEAT CATALOG NUMBER	L +.004 -.000	W +.004 -.000	T +.002 -.000	R1 +.002 -.000	R3	SHCS	S
SRTLK-25A-C	1.500	.625	.250	.312	.03	#6-32 x 1/4	1.100
SRTLK-50A-C	2.300	1.000	.400	.500	.05	1/4-20 x 3/8	1.650

Pocket dimensions shown. Screws included.

SQUARE GIBS



M H-13 **H** Core: 42-48 HRC, Surface: 70 HRC **S** Black Nitride

CAD insertion point

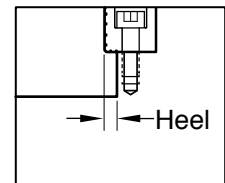
CATALOG NUMBER	W +.0005 -.0000	H +.000 -.005	L ±.005	NUMBER OF SCREW HOLES	Z CHAMFER	S1 ±.01	S2 ±.01	S3 ±.01	S4 ±.01	SHCS
SG50L6	.502	.495	6.00	4	.03	.75	2.25	—	.18	#8-32 x 1/2
SG50L10.5			10.50	6		.88	2.63	4.38		
SG75L10	.752	.745	10.00	4	.04	1.25	3.75	—	.25	1/4-20 x 7/8
SG75L13.5			13.50	6		1.13	3.38	5.63		
SG100L10	1.002	.995	10.00	4	.04	1.25	3.75	—	.37	5/16-18 x 1-1/8
SG100L13.5			13.50	6		1.13	3.38	5.63		

Screws included.

APPLICATION GUIDELINES

- Square Gibs are designed to be cut-to-length to make two Gibs out of one bar.
- The maximum heel size for each Square Gib is shown at right.

SIZE	HEEL
SG50	.125
SG75	.250
SG100	.312



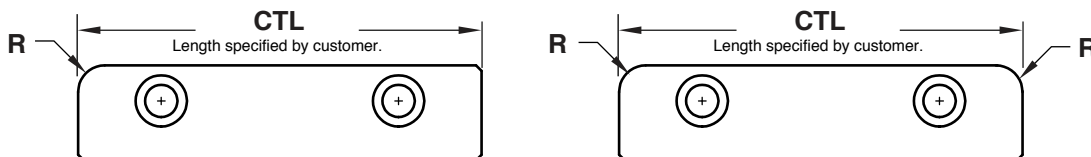
MOLD-READY GIBS

To Order:

Start with the prefix and the size from above. Example: SG75

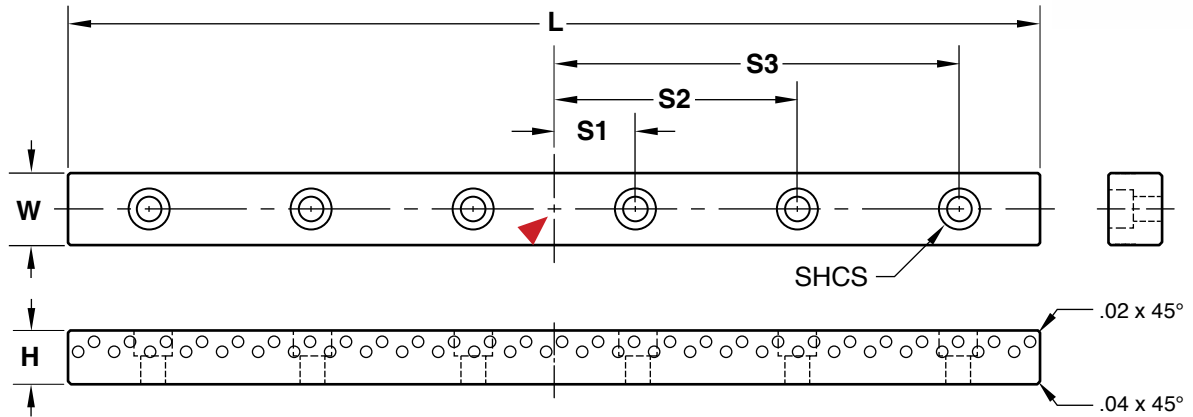
- For Gibs with no radii and cut-to-length, specify the length (CTL). Example: SG75L4.25
- For 1 corner radius as shown below left, specify the length followed by the 1R designation and then the required pocket radius. (The actual radius will be larger for clearance.) Example: SG75L4.25-1R.312
- For 2 corner radii as shown below right, specify the length followed by the 2R designation and then the required pocket radius. (The actual radii will be the same and will be larger for clearance.) Example: SG75L4.25-2R.312
- Submit the item number and quantity to Customer Service for a quotation.

Note: Screw sizes and locations will be the same as the standard Gibs. Any specifications outside of the modifications above can be quoted made-to-order by contacting tech@procomps.com.





CENTER GUIDES



M H-13 **H** Core: 42-48 HRC, Surface: 70 HRC **S** Black Nitride ▶ CAD insertion point

CATALOG NUMBER	W +.0000 -.0005	H +.000 -.005	L ±.005	NUMBER OF SCREW HOLES	S1 ±.01	S2 ±.01	S3 ±.01	SHCS
CG50X62L6	.4998	.620	6.00	4	.75	2.25	—	#8-32 x 3/4
CG50X62L10.5			10.50	6	.88	2.63	4.38	
CG75X62L10	.7498	.620	10.00	4	1.25	3.75	—	1/4-20 x 3/4
CG75X62L13.5			13.50	6	1.13	3.38	5.63	
CG100X75L10	.9998	.745	10.00	4	1.25	3.75	—	5/16-18 x 7/8
CG100X75L13.5			13.50	6	1.13	3.38	5.63	

Screws included.

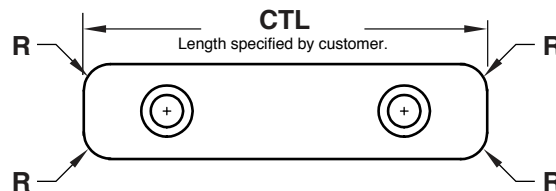
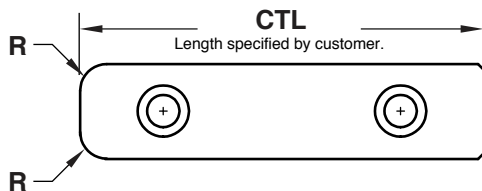
MOLD-READY GUIDES

To Order:

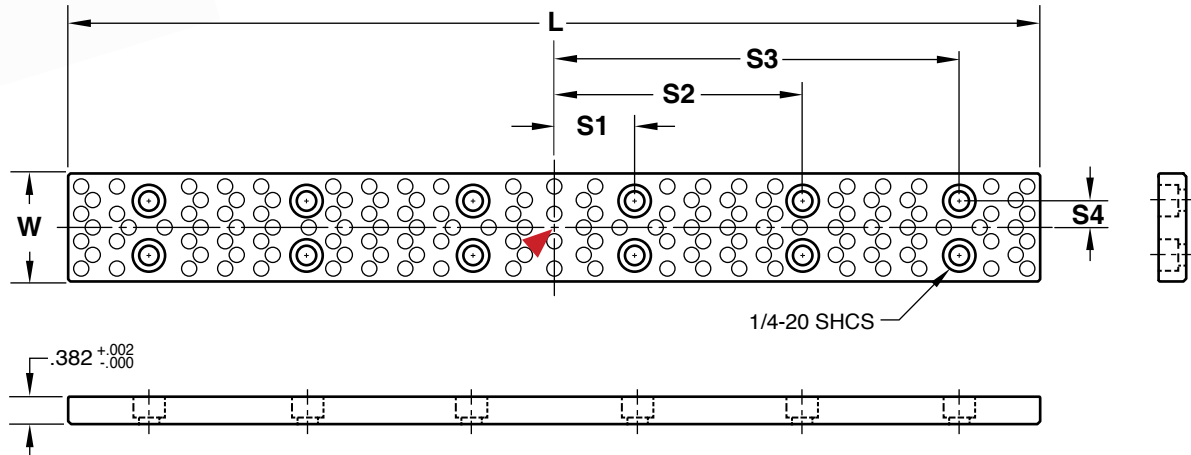
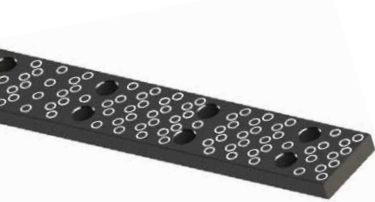
Start with the prefix and the size from above. Example: CG50X62

- For Guides with no radii and cut-to-length, specify the length (CTL). Example: CG50X62L4.25
- For 2 corner radii as shown below left, specify the length followed by the 2R designation and then the required pocket radius. (The actual radius will be larger for clearance.) Example: CG50X62L4.25-2R.312
- For 4 corner radii as shown below right, specify the length followed by the 4R designation and then the required pocket radius. (The actual radii will be the same and will be larger for clearance.) Example: CG50X62L4.25-4R.312
- Submit the item number and quantity to Customer Service for a quotation.

Note: Screw sizes and locations will be the same as the standard Guides. Any specifications outside of the modifications above can be quoted made-to-order by contacting tech@procomps.com.



WEAR STRIPS



M H-13 **H** Core: 42-48 HRC, Surface: 70 HRC **S** Black Nitride

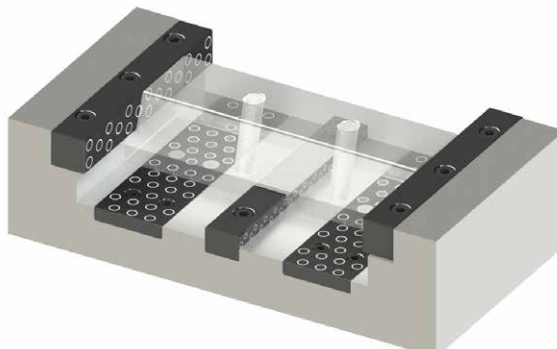
CATALOG NUMBER	W +.000 -.002	L ±.005	NUMBER OF SCREW HOLES	S1 ±.01	S2 ±.01	S3 ±.01	S4 ±.01
WS75L6	.749	6.00	4	.75	2.25	—	—
WS75L10.5		10.50	6	.88	2.63	4.38	—
WS100L10	.999	10.00	4	1.25	3.75	—	—
WS100L13.5		13.50	6	1.13	3.38	5.63	—
WS150L10	1.499	10.00	8	1.25	3.75	—	.375
WS150L13.5		13.50	12	1.13	3.38	5.63	
WS200L10	1.999	10.00	8	1.25	3.75	—	.500
WS200L13.5		13.50	12	1.13	3.38	5.63	

▶ CAD insertion point

1/4-20 x 1/2" long screws included.

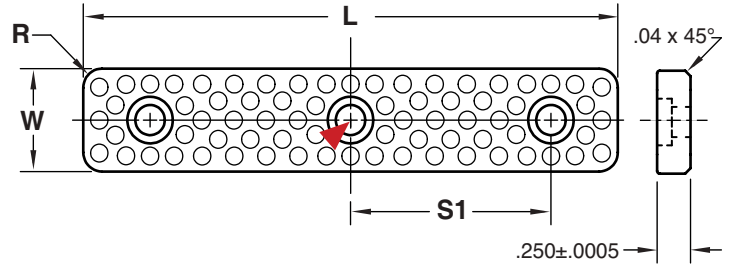
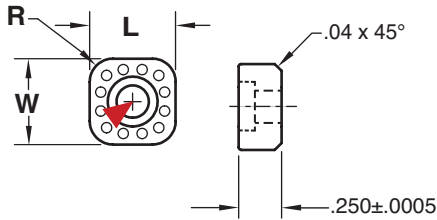
APPLICATION GUIDELINES

- Wear Strips can be cut to use in multiple areas and can be used in tandem with other Z-Series products as shown in the graphic below.
- For finish-machined Wear Plate options, refer to page G-21.





WEAR PLATES



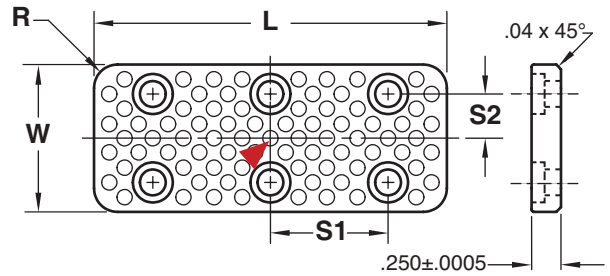
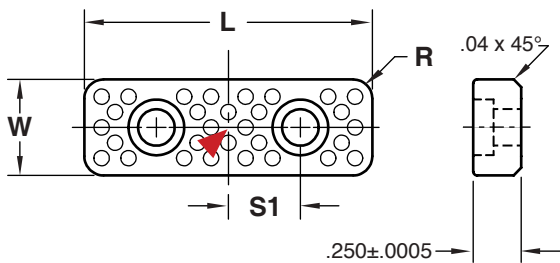
M H-13 **H** Core: 42-48 HRC, Surface: 70 HRC **S** Black Nitride

CATALOG NUMBER	W +.000 -.005	L +.000 -.005	R POCKET RADIUS	LHCS
WP050X050	.500	.500	.125	#8-32 x 3/8

▶ CAD insertion point

M H-13 **H** Core: 42-48 HRC, Surface: 70 HRC **S** Black Nitride

CATALOG NUMBER	W +.000 -.005	L +.000 -.005	S1 ±.01	R POCKET RADIUS	LHCS
WP050X250	.500	2.500	.87	.094	#8-32 x 3/8
WP050X350		3.500	1.37		
WP075X400	.750	4.000	1.50	.125	#10-32 x 3/8
WP075X600		6.000	2.50		



M H-13 **H** Core: 42-48 HRC, Surface: 70 HRC **S** Black Nitride

CATALOG NUMBER	W +.000 -.005	L +.000 -.005	S1 ±.01	R POCKET RADIUS	LHCS
WP050X150	.500	1.500	.37	.094	#8-32 x 3/8
WP075X200	.750	2.000	.50	.125	#10-32 x 3/8

M H-13 **H** Core: 42-48 HRC, Surface: 70 HRC **S** Black Nitride

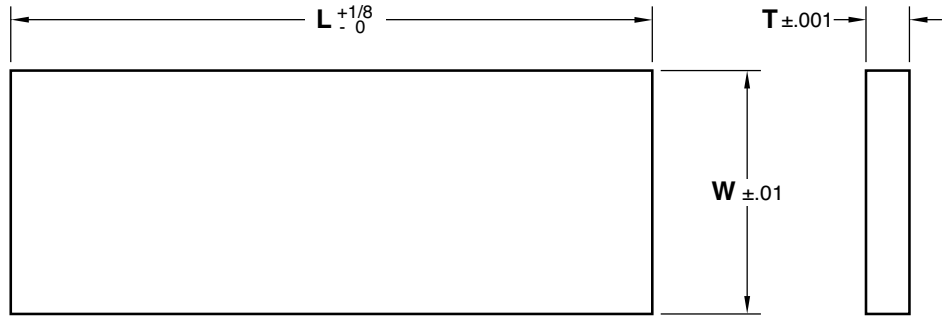
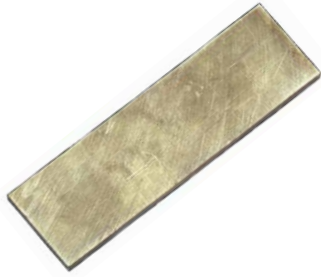
CATALOG NUMBER	W +.000 -.005	L +.000 -.005	S1 ±.01	S2 ±.01	R POCKET RADIUS	LHCS
WP125X300	1.250	3.000	1.00	.37	.187	#10-32 x 3/8
WP125X500	1.250	5.000	2.00	.37		
WP125X800	1.250	8.000	3.50	.37		
WP200X600	2.000	6.000	2.50	.62		
WP200X800	2.000	8.000	3.50	.62		
WP250X600	2.500	6.000	2.50	.75		
WP300X600	3.000					



APPLICATION GUIDELINES

- Standardized design is ready to install.
- Wear Plates can be cut as long as the edges have radii.
- Low Head Cap Screws included.

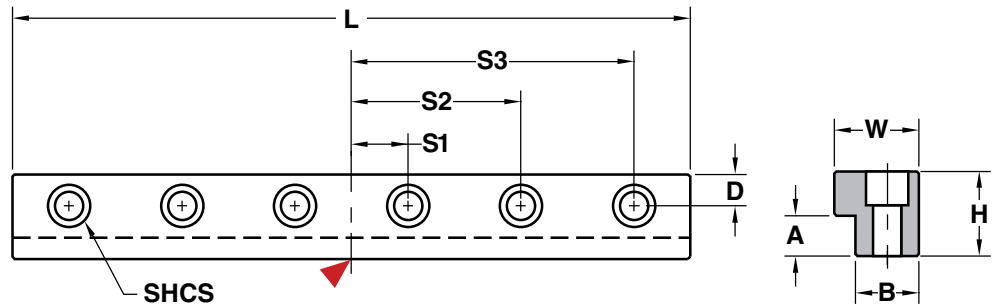
BRONZE WEAR PLATES



M CA954 Solid Bronze **H** 170 Brinell

T	W	L=4"	L=5"	L=6"	L=8"	L=10"	L=12"
1/4	1.000	WP25X1X4	WP25X1X5	WP25X1X6	WP25X1X8	WP25X1X10	WP25X1X12
	1.500	WP25X1.5X4	WP25X1.5X5	WP25X1.5X6	WP25X1.5X8	WP25X1.5X10	WP25X1.5X12
	2.000	WP25X2X4	WP25X2X5	WP25X2X6	WP25X2X8	WP25X2X10	WP25X2X12
	2.500	WP25X2.5X4	WP25X2.5X5	WP25X2.5X6	WP25X2.5X8	WP25X2.5X10	WP25X2.5X12
	3.000	WP25X3X4	WP25X3X5	WP25X3X6	WP25X3X8	WP25X3X10	WP25X3X12
	4.000	WP25X4X4	WP25X4X5	WP25X4X6	WP25X4X8	WP25X4X10	WP25X4X12
3/8	1.000	WP37X1X4	WP37X1X5	WP37X1X6	WP37X1X8	WP37X1X10	WP37X1X12
	1.500	WP37X1.5X4	WP37X1.5X5	WP37X1.5X6	WP37X1.5X8	WP37X1.5X10	WP37X1.5X12
	2.000	WP37X2X4	WP37X2X5	WP37X2X6	WP37X2X8	WP37X2X10	WP37X2X12
	2.500	WP37X2.5X4	WP37X2.5X5	WP37X2.5X6	WP37X2.5X8	WP37X2.5X10	WP37X2.5X12
	3.000	WP37X3X4	WP37X3X5	WP37X3X6	WP37X3X8	WP37X3X10	WP37X3X12
	4.000	WP37X4X4	WP37X4X5	WP37X4X6	WP37X4X8	WP37X4X10	WP37X4X12

L-GIBS



M CA954 Solid Bronze **H** 170 Brinell

CAD insertion point

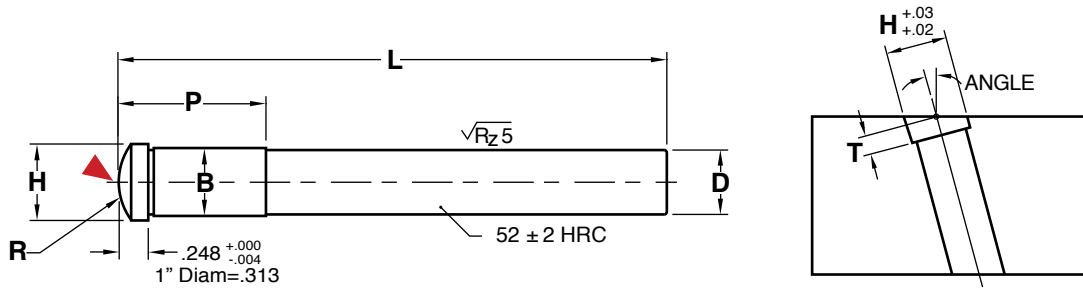
CATALOG NUMBER	W +.002 -.000	L +.125 -.000	H ±.005	A +.002 -.000	B +.002 -.000	NUMBER OF SCREW HOLES	SHCS	S1 ±.01	S2 ±.01	S3 ±.01	D
LGIB75L5.25	.750	5.25	.750	.312	.563	3	1/4	1.62	—	—	.281
LGIB75L8.75	.750	8.75	.750	.312	.563	4	1/4	1.00	3.37	—	.281
LGIB100L6	1.000	6.00	.750	.375	.750	4	5/16	.75	2.25	—	.375
LGIB100L10	1.000	10.00	.750	.375	.750	4	5/16	1.25	3.75	—	.375
LGIB125L6	1.250	6.00	.875	.500	.875	4	3/8	.75	2.25	—	.438
LGIB125L10	1.250	10.00	.875	.500	.875	4	3/8	1.25	3.75	—	.438
LGIB150L9	1.500	9.00	1.250	.750	1.000	4	3/8	1.12	3.37	—	.500
LGIB150L15	1.500	15.00	1.250	.750	1.000	6	3/8	1.25	3.75	6.25	.500

To Order Undrilled L-Gibs:

- Specify "N" at the end of the catalog number. Example: LGIB150L9N.



ANGLE PINS

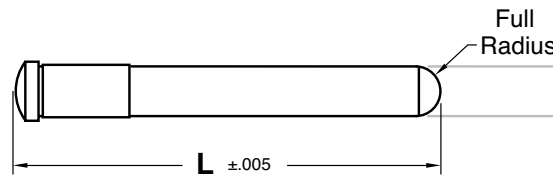


M 8620 **H** Surface: 50-54 HRC

CAD insertion point

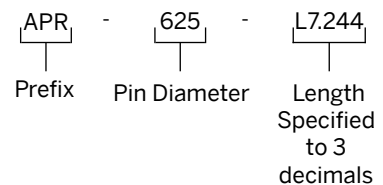
NOMINAL DIAMETER	CATALOG NUMBER	D +.0000 -.0005	L +1/8 -0	B +.0005 -.0000	H +.000 -.010	R HEAD RADIUS	P PRESS FIT LENGTH	ANGLE	T DEPTH	
3/8	AP375L6	.374	6	.376	.500	.375	.75	10°	.258	
	AP375L10		10					15°	.265	
			1.25					20°	.276	
1/2	AP500L6	.499		6	.501	.500	.75	10°	.260	
	AP500L10			10				15°	.270	
			1.25	20°				.284		
5/8	AP625L6	.624		6	.626	.750	.625	.75	10°	.262
	AP625L10			10					15°	.274
			1.25	20°					.292	
3/4	AP750L10	.749		10	.751	.875	.750	1.25	10°	.264
	AP750L14			14					15°	.278
			1	.999					10	1.001
AP1000L10	14	25°			.329					
		10°			.332					
1	AP1000L14	.999	14	1.001	1.118	1.000	1.31	15°	.352	
								20°	.381	
								25°	.420	

MOLD-READY ANGLE PINS



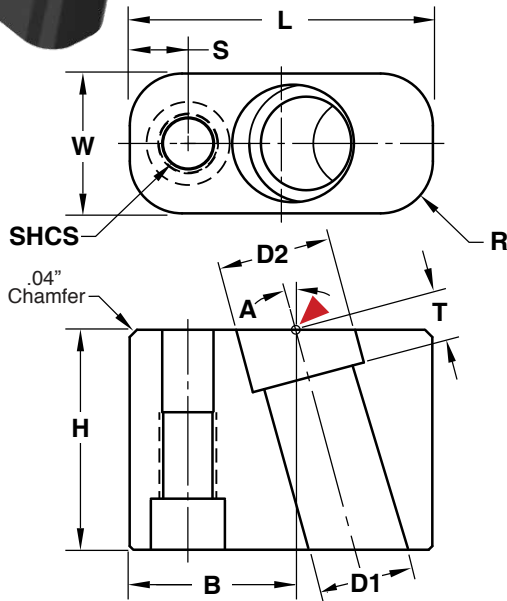
To Order:

- A full radius option can be ordered by specifying the prefix of "APR" and the diameter as outlined above, plus "L" and the length required.
- Example: APR625L7.244 (no dashes/spaces) is an Angle Pin with a 5/8" diameter machined to 7.244" long with a full radius.
- Note: P will remain as shown in table above.



ANGLE PIN HOLDERS

IN-LINE BOLT

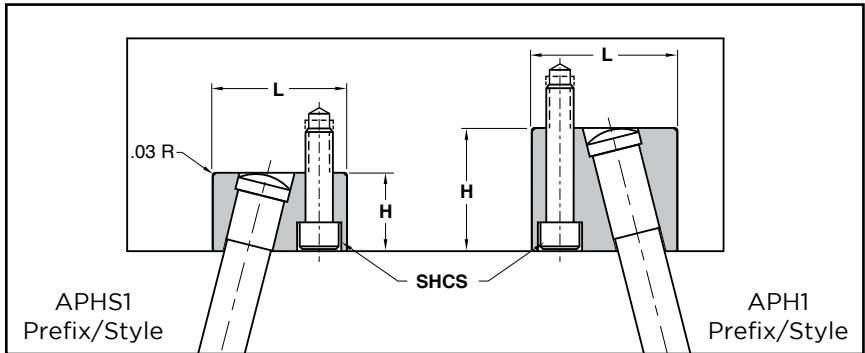


APPLICATION GUIDELINES

- Angle Pin Holders are provided with 10°, 15°, or 20° angles and allow for machining and installation from parting line.
- The In-Line Single Bolt version has a narrow design where space is limited.
- Angle Pins are sold separately on page G-23.
- Includes (1) Socket Head Cap Screw as shown in the chart.

Installation:

1. Machine pockets to nominal sizes as shown in chart.
2. Install Angle Pin from top of Holder.
3. Place entire unit in plate and fasten with the screw.



M 4140 **H** 28-32 HRC **S** Black Oxide

CAD insertion point

CATALOG NUMBER	ANGLE PIN DIA.	H + .000 - .003	L + .000 - .001	W + .000 - .001	R POCKET RADIUS	S ± .01	A ANGLE	T	B	D1 ± .0002	D2 + .005 - .000	SHCS
APHS1-37-10	3/8	.875	1.250	.625	.187	.31	10°	.258	.813	.3764	.505	1/4-20 x 1
APH1-37-10		1.375	1.375									1/4-20 x 1-1/2
APHS1-37-15		.875	1.375				15°	.265				1/4-20 x 1
APH1-37-15		1.375	1.500									1/4-20 x 1-1/2
APHS1-37-20		.875	1.500				20°	.276				1/4-20 x 1
APH1-37-20		1.375	1.625									1/4-20 x 1-1/2
APHS1-50-10	1/2	.875	1.375	.750	.250	.31	10°	.260	.875	.5014	.630	1/4-20 x 1
APH1-50-10		1.375	1.500									1/4-20 x 1-1/2
APHS1-50-15		.875	1.500				15°	.270				1/4-20 x 1
APH1-50-15		1.375	1.625									1/4-20 x 1-1/2
APHS1-50-20		.875	1.625				20°	.284				1/4-20 x 1
APH1-50-20		1.375	1.750									1/4-20 x 1-1/2
APHS1-63-10	5/8	.875	1.625	.875	.313	.37	10°	.262	1.063	.6264	.755	5/16-18 x 1
APH1-63-10		1.375	1.750									5/16-18 x 1-1/2
APHS1-63-15		.875	1.750				15°	.274				5/16-18 x 1
APH1-63-15		1.375	1.875									5/16-18 x 1-1/2
APHS1-63-20		.875	1.875				20°	.292				5/16-18 x 1
APH1-63-20		1.375	2.000									5/16-18 x 1-1/2
APH1-75-10	3/4	1.500	2.000	1.000	.375	.37	10°	.264	1.188	.7514	.885	3/8-16 x 1-5/8
APH1-75-15			2.125				15°	.278				
APH1-75-20			2.250				20°	.300				
APH1-100-10	1	1.500	2.625	1.500	.375	.50	10°	.332	1.500	1.0014	1.134	1/2-13 x 1-3/4
APH1-100-15			2.750				15°	.352				
APH1-100-20			2.875				20°	.381				



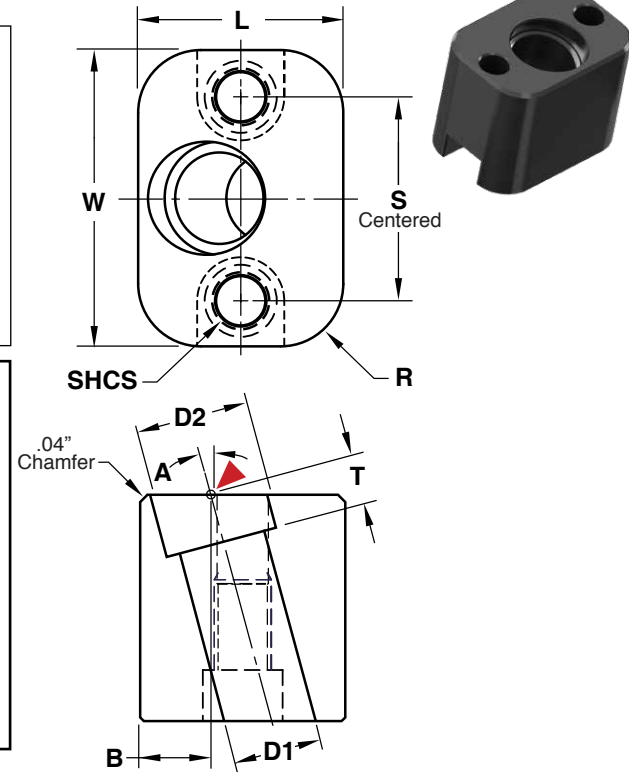
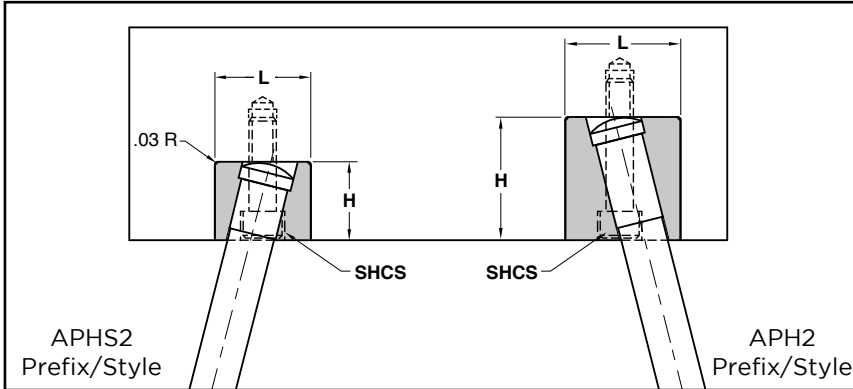
ANGLE PIN HOLDERS OUTER BOLTS

APPLICATION GUIDELINES

- The Outer Bolt version installs with two screws and only takes up a minimal amount of space behind the pin.
- Includes (2) Socket Head Cap Screws as shown in the chart.
- Angle Pins are sold separately on page G-23.

Installation:

1. Machine pockets to nominal sizes as shown in chart.
2. Install Angle Pin from top of Holder.
3. Place entire unit in plate and fasten with the screws.

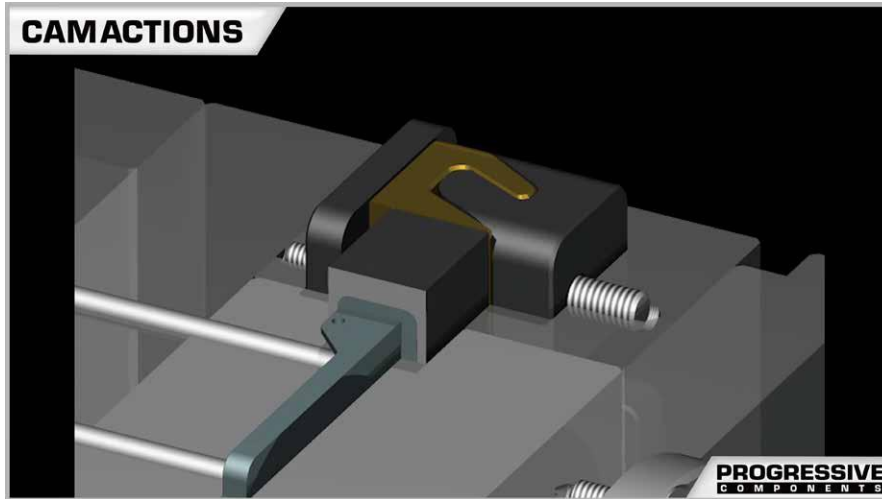


M 4140 **H** 28-32 HRC **S** Black Oxide

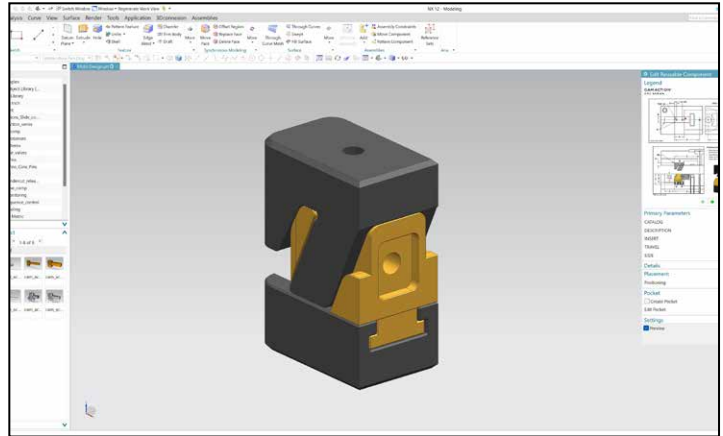
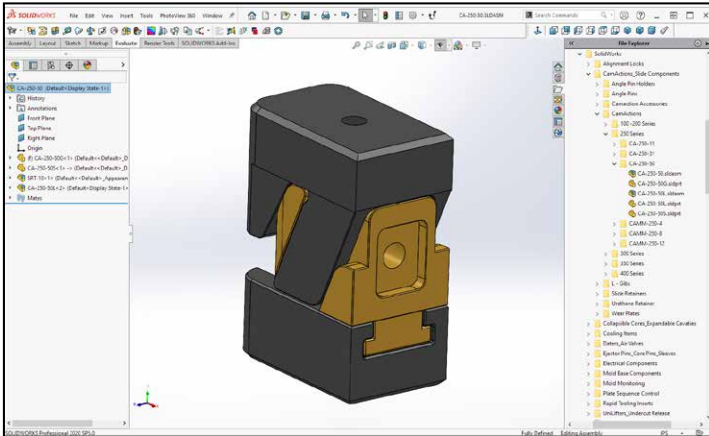
CAD insertion point

CATALOG NUMBER	ANGLE PIN DIA.	H +.000 -.003	L +.000 -.001	W +.000 -.001	R POCKET RADIUS	S ± .01	A ANGLE	T	B	D1 ±.0002	D2 +.005 -.000	SHCS	
APHS2-37-10	3/8	.875	.750	1.500	.250	1.00	10°	.258	.312	.3764	.505	1/4-20 x 1	
APH2-37-10		1.375	.875									1/4-20 x 1-1/2	
APHS2-37-15		.875	.875				15°	.265				1/4-20 x 1	
APH2-37-15		1.375	1.000									1/4-20 x 1-1/2	
APHS2-37-20		.875	1.000				20°	.276				1/4-20 x 1	
APH2-37-20		1.375	1.125									1/4-20 x 1-1/2	
APHS2-50-10	1/2	.875	.875	1.625	.313	1.12	10°	.260	.375	.5014	.630	1/4-20 x 1	
APH2-50-10		1.375	1.000									1/4-20 x 1-1/2	
APHS2-50-15		.875	1.000				15°	.270				1/4-20 x 1	
APH2-50-15		1.375	1.125									1/4-20 x 1-1/2	
APHS2-50-20		.875	1.125				20°	.284				1/4-20 x 1	
APH2-50-20		1.375	1.250									1/4-20 x 1-1/2	
APHS2-63-10	5/8	.875	1.125	1.875	.375	1.37	10°	.262	.500	.6264	.755	5/16-18 x 1	
APH2-63-10		1.375	1.250									5/16-18 x 1-1/2	
APHS2-63-15		.875	1.250				15°	.274				5/16-18 x 1	
APH2-63-15		1.375	1.375									5/16-18 x 1-1/2	
APHS2-63-20		.875	1.375				20°	.292				5/16-18 x 1	
APH2-63-20		1.375	1.500									5/16-18 x 1-1/2	
APH2-75-10	3/4	1.500	1.375	2.000	.375	1.50	10°	.264	.563	.7514	.885	5/16-18 x 1-5/8	
APH2-75-15			1.500				15°						.300
APH2-75-20			1.625				20°						
APH2-100-10	1	1.500	1.875	2.625	.375	2.00	10°	.332	.750	1.0014	1.134	3/8-16 x 1-3/4	
APH2-100-15			2.000				15°						.381
APH2-100-20			2.125				20°						

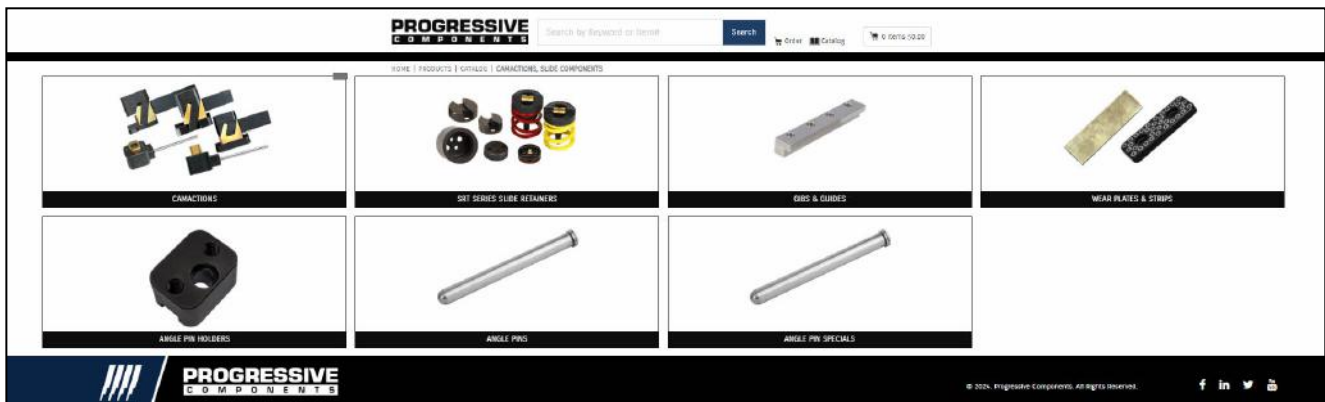
ONLINE RESOURCES



When considering design options, numerous animations can be viewed at procomps.com/animations.



CAD geometry is available online as individual downloads or as part of the CADalog system. The seven formats include: IGES (.igs), ACIS (.sat), STEP (.step), Parasolid (.x_t), SolidWorks (.sldasm), NX (.prt) (Re-Use and MoldWizard) and Visi (.wfk).



Industry-leading web store expedites the purchasing process. Go to shop.procomps.com for information and additional resources.



LIFTERS

UNDERCUT RELEASE

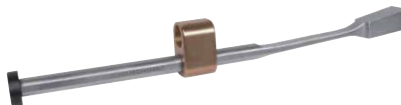
SECTION H



UniLifter Undercut Release (UL-Series)	UniLifter Undercut Release (C-Series)	Versa-Lifter System
Prefix: CB, UC, TG	Prefix: CB, CC, CG	Prefix: UGV, SGV, CBV
Page: H-1	Page: H-1	Page: H-7



Spherical Bushings	Lifter Guides	Lifter Head Key
Prefix: LSB	Prefix: LG, SGV	Prefix: LHK
Page: H-9	Page: H-10	Page: H-11

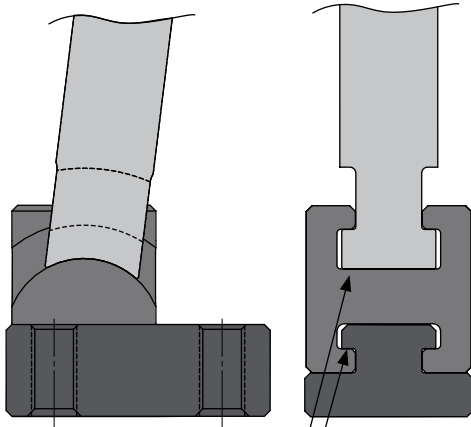
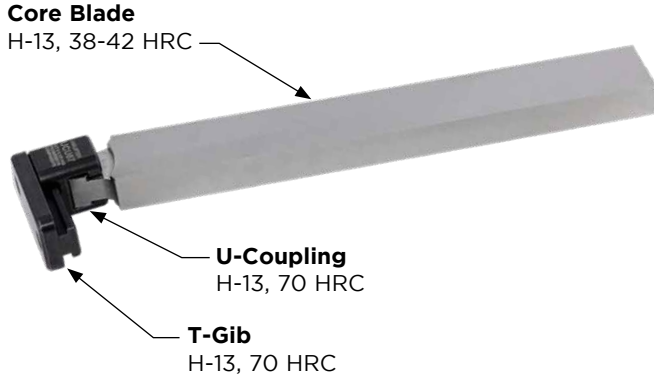


ModuLifter System	FlexiCore System
Prefix: MLB, MLC, MLR, MLH	Prefix: FCA, FCR, FCDA
Page: H-12	Page: H-18

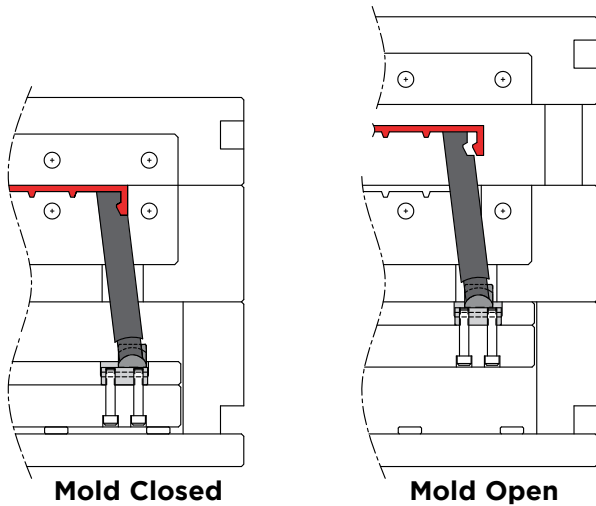


UNILIFTER®
UNDERCUT RELEASE LIFTER

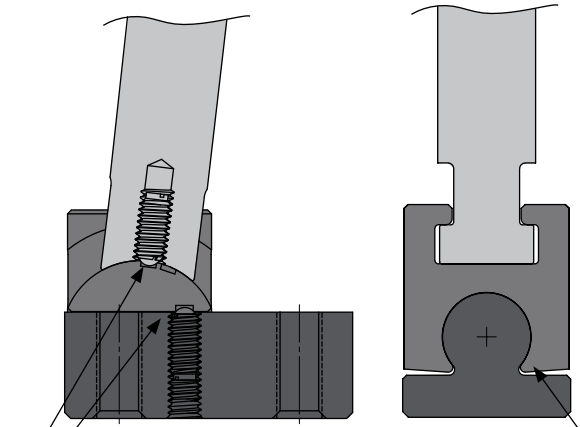
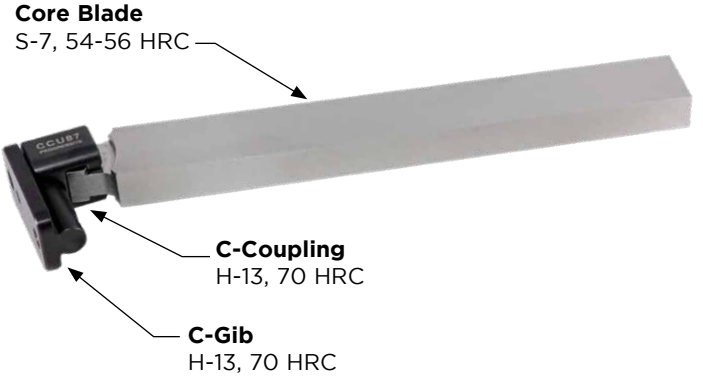
UNILIFTER: UL-SERIES



The T-slot's large surface contact is designed to withstand extreme force and run smoothly without binding.

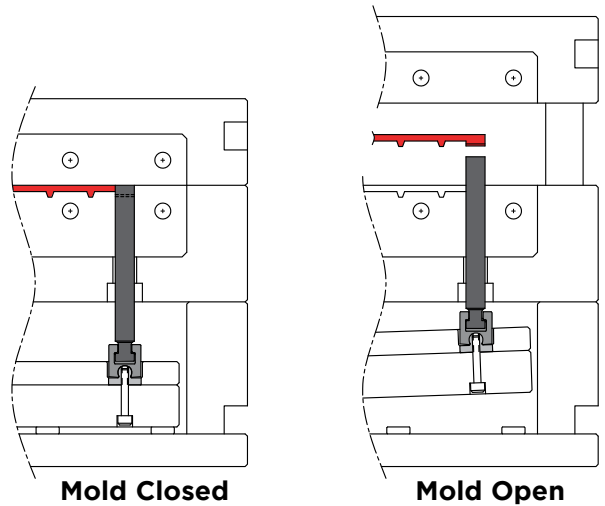


UNILIFTER: C-SERIES



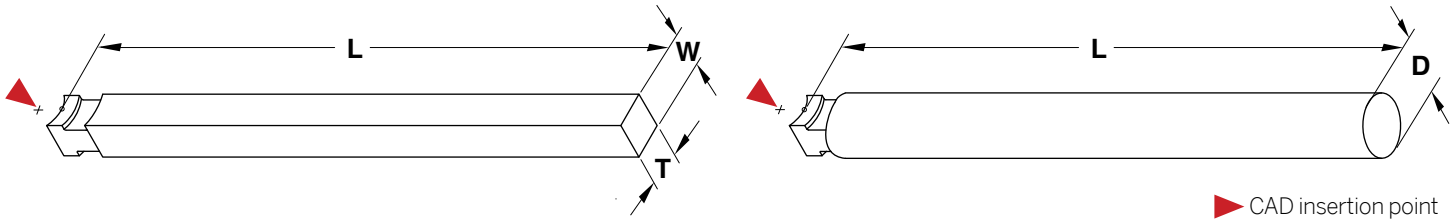
Click-in-place assembly feature sets the components to the required operating position, allowing for simplified insertion into the mold plate pockets.

Self-adjusting cylindrical design to compensate for severe ejector plate misalignment or warpage.



CORE BLADES

INCH STANDARD



Flat Core Blades			H-13 38-42 HRC		S-7 54-56 HRC		COUPLINGS
T +.000 -.001	W +.000 -.001	SIZE	L=8" +.06 -.00	L=18" +.06 -.00	L=8" +.06 -.00	L=18" +.06 -.00a	
.385	.260	Mini	CBS37X25L8	CBS37X25L18	CBS7X37X25L8	CBS7X37X25L18	UL-Series: UCM50 C-Series: CCM50
.510	.260		CBS50X25L8	CBS50X25L18	CBS7X50X25L8	CBS7X50X25L18	
.760	.385		CBS75X37L8	CBS75X37L18	CBS7X75X37L8	CBS7X75X37L18	

Note: S-7 Core Blades come with the assembly detent installed.

Flat Core Blades			H-13 38-42 HRC			S-7 54-56 HRC			COUPLINGS
T +.000 -.001	W +.000 -.001	SIZE	L=8" +.06 -.00	L=14" +.06 -.00	L=20" +.06 -.00	L=8" +.06 -.00	L=14" +.06 -.00	L=20" +.06 -.00	
.510	.510	UL	CBS50X50L8	CBS50X50L14	CBS50X50L20	CBS7X50X50L8	CBS7X50X50L14	CBS7X50X50L20	UL-Series: UCU87 C-Series: CCU87
.510	.760		CBS50X75L8	CBS50X75L14	CBS50X75L20	CBS7X50X75L8	CBS7X50X75L14	CBS7X50X75L20	
.510	1.010		CBS50X100L8	CBS50X100L14	CBS50X100L20	CBS7X50X100L8	CBS7X50X100L14	CBS7X50X100L20	
.510	1.510		—	CBS50X150L14	CBS50X150L20	—	—	—	
.760	.510		—	CBS75X50L14	CBS75X50L20	—	—	—	
.760	1.510		CBS75X150L8	CBS75X150L14	CBS75X150L20	—	CBS7X75X150L14	CBS7X75X150L20	
1.010	.510		CBS100X50L8	CBS100X50L14	CBS100X50L20	—	CBS7X100X50L14	CBS7X100X50L20	
1.510	.510		CBS150X50L8	CBS150X50L14	CBS150X50L20	—	—	—	
1.510	.760		CBS150X75L8	CBS150X75L14	CBS150X75L20	—	CBS7X150X75L14	CBS7X150X75L20	

Note: S-7 Core Blades come with the assembly detent installed.

Flat Core Blades			H-13 38-42 HRC		COUPLINGS
T +.000 -.001	W +.000 -.001	SIZE	L=10" +.06 -.00	L=18" +.06 -.00	
1.010	1.010	XL	CBS100X100L10	CBS100X100L18	UL-Series: UCX175
1.010	1.510		CBS100X150L10	CBS100X150L18	
1.510	1.010		CBS150X100L10	CBS150X100L18	

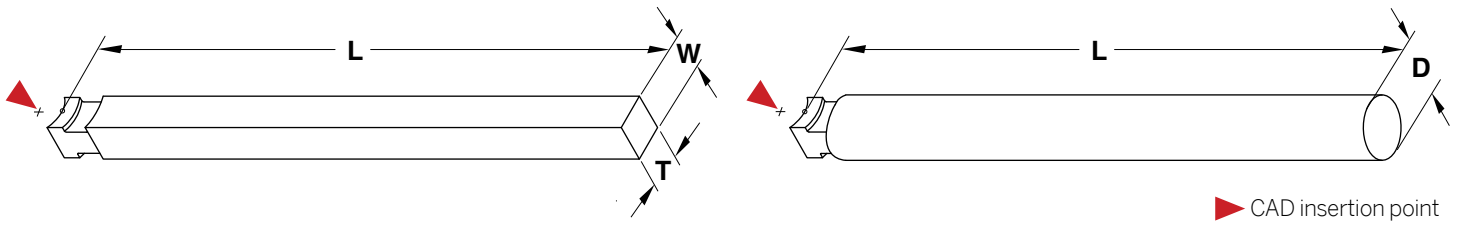
Round Core Blades		H-13 38-42 HRC					COUPLINGS
D +.000 -.001	SIZE	L=8" +.06 -.00	L=10" +.06 -.00	L=14" +.06 -.00	L=18" +.06 -.00	L=24" +.06 -.00	
.437	Mini	CBS43DL8	—	—	CBS43DL18	—	UL-Series: UCM50 C-Series: CCM50
.500		CBS50DL8	—	—	CBS50DL18	—	
.750	UL	CBS75DL8	—	CBS75DL14	CBS75DL18	CBS75DL24	UL-Series: UCU87 C-Series: CCU87
1.250	XL	—	CBS125DL10	—	CBS125DL18	—	UL-Series: UCX175

For Core Blades in different materials or sizes, refer to the templates at procomps.com.



CORE BLADES

METRIC STANDARD



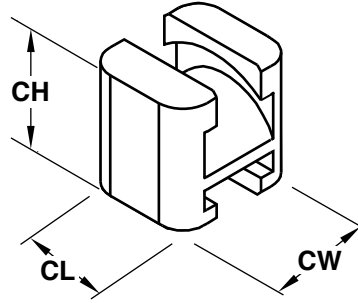
Flat Core Blades			H-13 48-50 HRC	DC53 58-60 HRC	H-13 38-42 HRC		S-7 54-56 HRC	COUPLINGS
T -0.005 -0.015	W -0.005 -0.015	SIZE	L=200MM +2 +0					
6.00	6.00	Metric Mini	CBMMH6X6L200	CBMMP6X6L200	—	—	—	UL-Series: UCMM16
6.00	10.00		CBMMH6X10L200	CBMMP6X10L200	—	—	—	
8.00	6.00		CBMMH8X6L200	CBMMP8X6L200	—	—	—	
8.00	8.00		CBMMH8X8L200	CBMMP8X8L200	—	—	—	
10.00	8.00		CBMMH10X8L200	CBMMP10X8L200	—	—	—	
T +0.000 -0.025	W +0.000 -0.025	SIZE			L=250MM +2 +0	L=400MM +2 +0	L=250MM +2 +0	COUPLINGS
10.25	10.25	Metric	—	—	CBMM10X10L250	—	CBMMS7X10X10L250	UL-Series: UCMM22
10.25	20.25		—	—	CBMM10X20L250	—	—	
15.25	15.25		—	—	CBMM15X15L250	—	CBMMS7X15X15L250	
15.25	30.25		—	—	—	CBMM15X30L400	—	C-Series: CCMM22
20.25	10.25		—	—	CBMM20X10L250	—	—	
20.25	20.25		—	—	—	CBMM20X20L400	—	
30.25	15.25		—	—	—	CBMM30X15L400	—	

Note: S-7 Core Blades come with the assembly detent installed.

Round Core Blades		H-13 48-50 HRC	DC53 58-60 HRC	H-13 38-42 HRC	COUPLINGS
D -0.005 -0.014	SIZE	L=200MM +2 +0			
8.00	Metric Mini	CBMMH8DL200	CBMMP8DL200	—	UL-Series: UCMM16
D +0.000 -0.025	SIZE			L=250MM +2 +0	COUPLINGS
10.00	Metric	—	—	CBMM10DL250	UL-Series: UCMM22 C-Series: CCMM22
15.00		—	—	CBMM15DL250	

UNILIFTER: UL-SERIES COMPONENTS

U-COUPPLINGS



Inch Standard

M H-13 **H** Core: 40-44 HRC Surface: 70 HRC
S Black Nitride

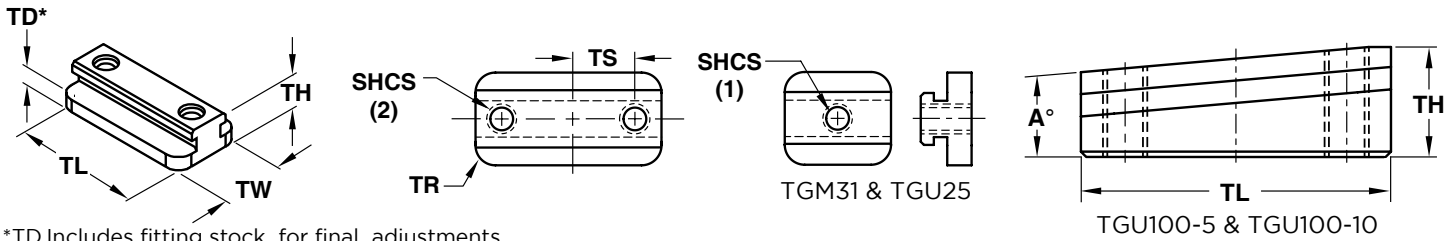
SIZE	CATALOG NUMBER	CW	CL	CH
Mini	UCM50	.50	.44	.62
UL	UCU87	.87	.75	.87
XL	UCX175	1.75	1.50	1.65

Metric Standard

M H-13 **H** Core: 40-44 HRC Surface: 70 HRC
S Black Nitride

SIZE	CATALOG NUMBER	CW	CL	CH
Metric Mini	UCMM16	16	14	21
Metric	UCMM22	22	18	25

T-GIBS



*TD Includes fitting stock for final adjustments.

Inch Standard

M H-13 **H** Core: 40-44 HRC Surface: 70 HRC **S** Black Nitride

SIZE	CATALOG NUMBER	TRAVEL ALLOWED	TW +.000 -.001	TH +.010 -.000	TD* +.010 -.000	TR	TS ±.01	TL +.000 -.010	A ANGLE	SHCS (INCLUDED)
Mini	TGM31	.312	.500	.500	.344	.093	—	.750	—	#10-32 x 1
	TGM100	1.000					.50	1.50	—	
UL	TGU25	.250	.875	.468	.219	.187	—	1.00	—	1/4-20 x 3/4
	TGU50	.500					.37	1.25	—	
	TGU100	1.000		—			—	—		
	TGU100-5	1.000		.62			1.75	5°		
	TGU100-10	1.000		.75			1.75	10°		
XL	TGU150	1.500	1.750	.468	.250	.312	.75	2.25	—	3/8-16 x 1-1/4
	TGX50	.500					.62	2.00	—	
	TGX100	1.000					.87	2.50	—	
	TGX250	2.500					1.37	4.00	—	

Metric Standard

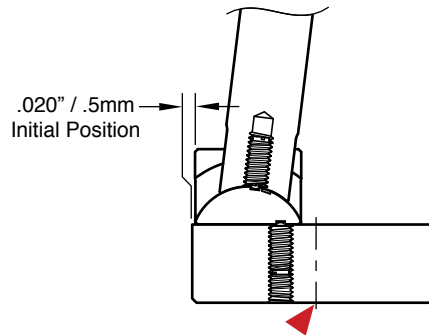
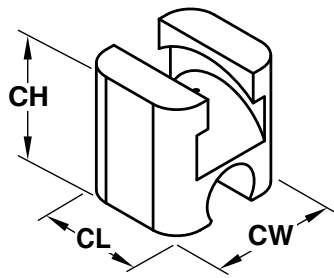
M H-13 **H** Core: 40-44 HRC Surface: 70 HRC **S** Black Nitride

SIZE	CATALOG NUMBER	TRAVEL ALLOWED	TW +.000 -.025	TH +.25 -.00	TD* +.25 -.00	TR	TS ±.25	TL +.00 -.25	SHCS (INCLUDED)
Mini	TGMM16	18	16	13	6	2.5	10	33	M4-.7x20
UL	TGMM10	15	22	13	6	5	10	33	M5-0.8 x 20
	TGMM30	34					15	52	



UNILIFTER: C-SERIES COMPONENTS

C-COUPPLINGS



Inch Standard

M H-13 **H** Core: 40-44 HRC Surface: 70 HRC

S Black Nitride

SIZE	CATALOG NUMBER	CW	CL	CH
Mini	CCM50	.50	.44	.70
UL	CCU87	.87	.75	.87

Metric Standard

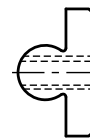
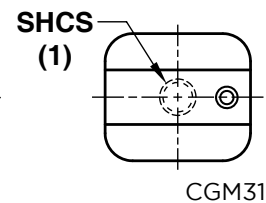
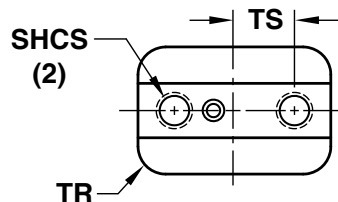
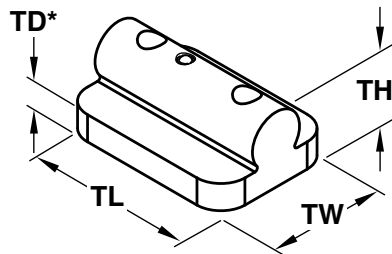
M H-13 **H** Core: 40-44 HRC Surface: 70 HRC

S Black Nitride

SIZE	CATALOG NUMBER	CW	CL	CH
Metric	CCMM22	22	18	24

▶ CAD insertion point

C-GIBS



*TD Includes fitting stock for final adjustments.

Inch Standard

M H-13 **H** Core: 40-44 HRC Surface: 70 HRC **S** Black Nitride

SIZE	CATALOG NUMBER	TRAVEL ALLOWED	TW +.000 -.001	TH +.010 -.000	TD* +.010 -.000	TR	TS ±.01	TL +.000 -.010	SHCS (INCLUDED)
Mini	CGM31	.312	.500	.550	.250	.093	—	.750	#10-32 x 1
	CGM100	1.000					.50	1.50	
UL	CGU50	.500	.875	.540	.187	.187	.37	1.25	1/4-20 x 3/4
	CGU100	1.000					.62	1.75	

Metric Standard

M H-13 **H** Core: 40-44 HRC Surface: 70 HRC **S** Black Nitride

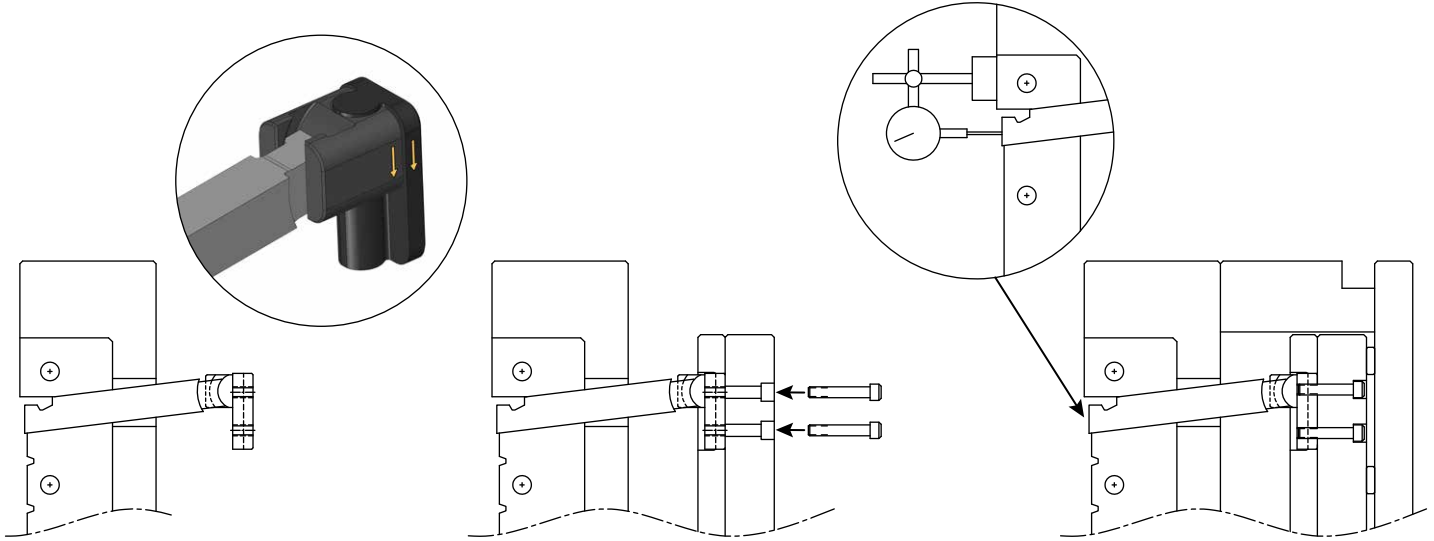
SIZE	CATALOG NUMBER	TRAVEL ALLOWED	TW +.000 -.025	TH +.25 -.00	TD* +.25 -.00	TR	TS ±.25	TL +.00 -.25	SHCS (INCLUDED)
UL	CGMM10	15	22	15	6	5	10	33	M5-0.8 x 20

APPLICATION GUIDELINES

- C-Series Gibs come with the assembly detent installed.
- Screw thread is not through top of the C-Gib on the Mini sizes.

C-SERIES LIFTER SYSTEMS

INSTALLATION INSTRUCTIONS / APPLICATION GUIDELINES



1 Install Core Blade, C-Gib and C-Coupling into the mold base. Align arrows to orient with ejection travel.

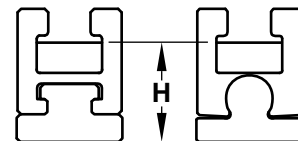
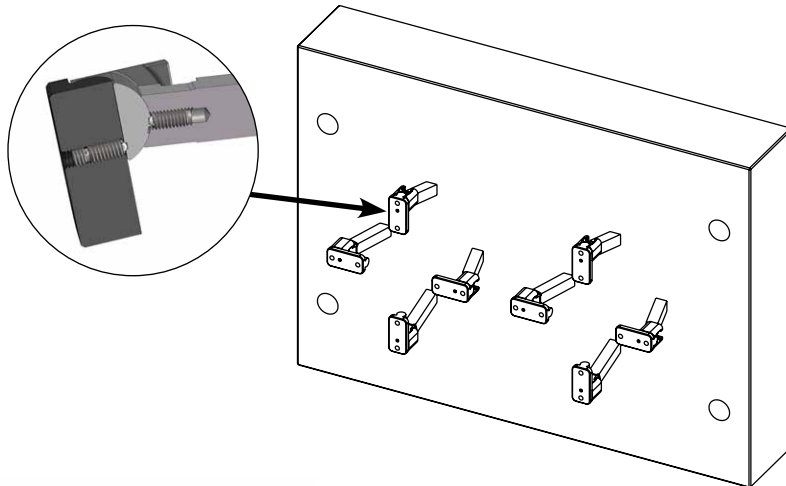
2 Assemble the ejector plates and fasten the C-Gib into the pocket.

3 With the mold assembled, check to verify final position of the lifter. Adjust by grinding the back of the C-Gib as required.

C-Series Lifter Features

Assembly detents allow the toolmaker to set the Core Blade, C-Coupling and C-Gib to the correct angle and position, allowing easy assembly into the mold pocket without parts sliding out of position.

Maintenance Option: Should ejector plates warp over time, the C-Series Gib and Coupling can directly replace the UniLifter Series without altering the Core Blades.



SIZE	H
Mini	.719"
UL	.812"
Metric	22mm

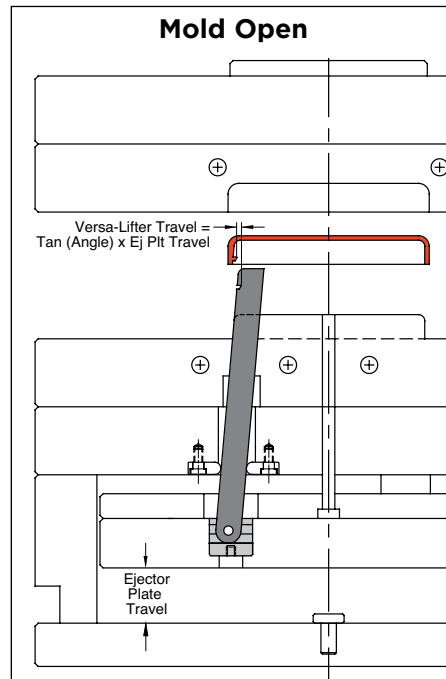
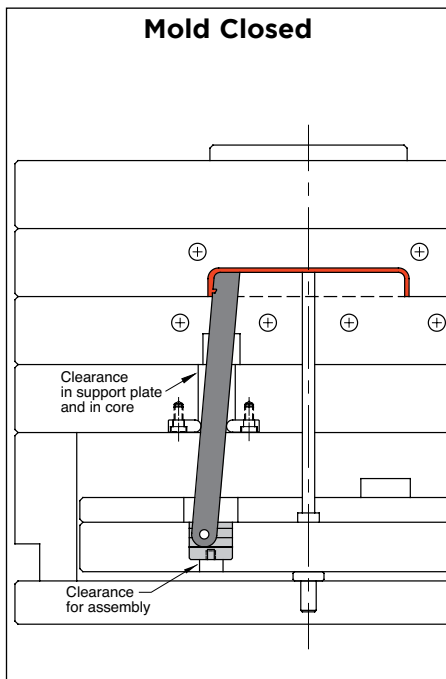
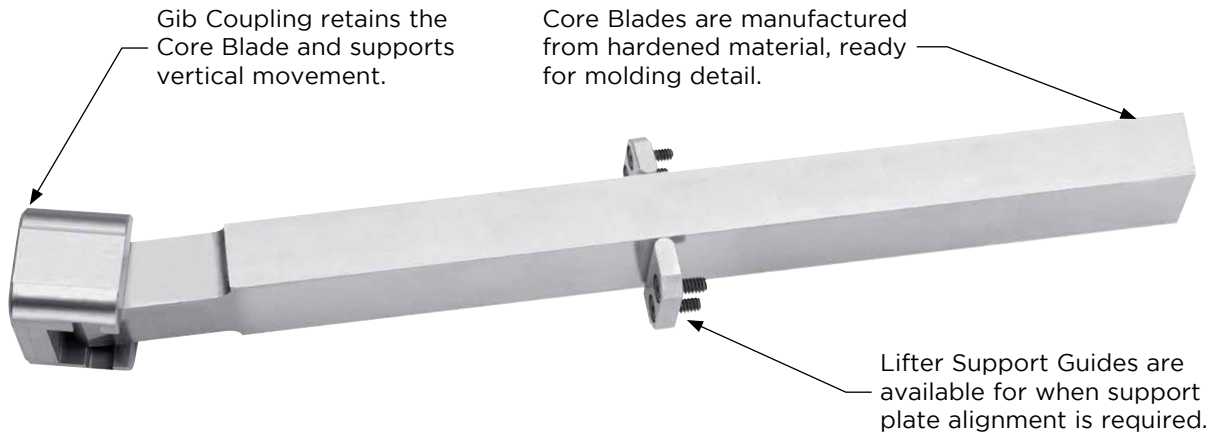


UL-SERIES & C-SERIES APPLICATION GUIDELINES

- Typical Core Blade angle is 5-10°. For greater angles, Lifter Guides are recommended.
- Lifter Guides are also recommended if less than half of the Core Blade is bearing in the insert. Refer to page H-10 for Guides.
- Typical clearance is .001"-.0015" (.02-.04 mm), or a 3° taper on the Core Blade T & W to eliminate contact and friction.
- Core Blades are interchangeable between the UL-Series and C-Series.
- If treating the S-7 Core Blades, the assembly ball plunger should be removed prior to processing.
- For any questions including the availability of water-cooled Core Blades (as shown at left) or unusual applications, contact Progressive for an application review at tech@procomps.com.



VERSA-LIFTER™ UNDERCUT RELEASE SYSTEM

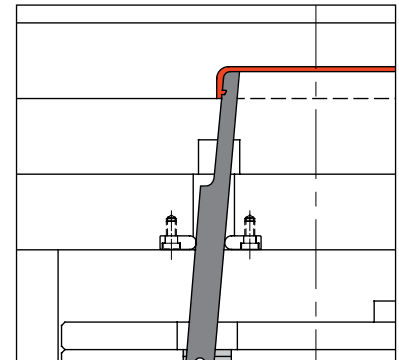
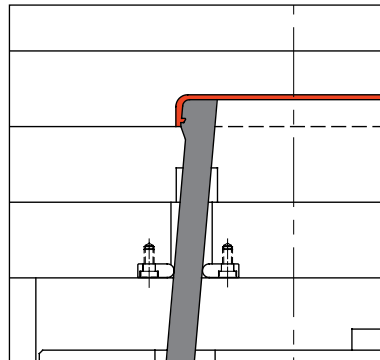


APPLICATION GUIDELINES

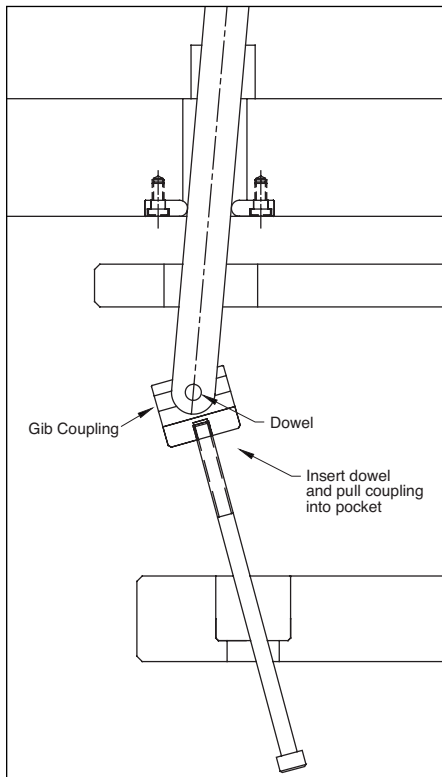
- Typical angles are 5-10°, but users have reported success at larger angles for unique applications with greater bearing, such as cavity side core pulls. Contact tech@procomps.com for an application review.
- Guided Ejection is required, and the Lifter Support Guides are recommended in all applications. (See page H-10)
- Recommended total clearance is .001"-.0015" (.025-.038mm) where permissible.
- Core material should be at least 10 HRC different than the Core Blade material.
- Locking angles can be designed to counter molding pressure.
- Made-to-order Core Blades can be provided by sending a request to tech@procomps.com.

Design Options

- For positive return, a locking angle can be designed into the Core Blade as shown at right.
- In addition, if space is limited at parting line, the Core Blade can be stepped.



VERSA-LIFTER™
CORE BLADES

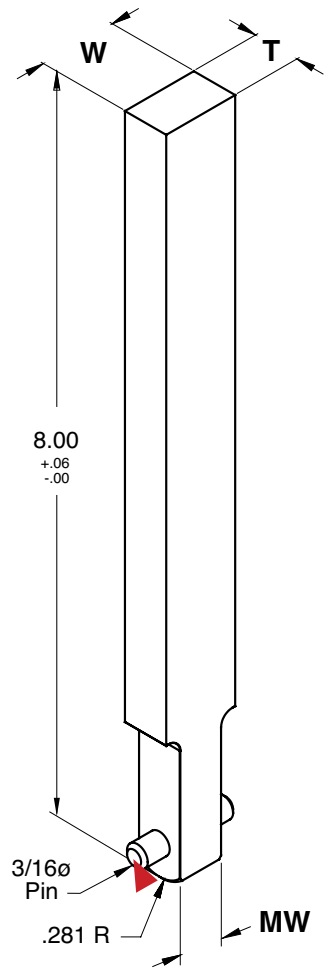


M Bohler K340 **H** 58-60 HRC

CATALOG NUMBER	T +.0000 -.0003	W +.0000 -.0003	MW +.000 -.001
CBV50X18L8	.5000	.1875	.188
CBV50X43L8		.4375	.188
CBV50X62L8		.6250	.375
CBV50X87L8		.8750	.625
CBV50X112L8		1.1250	.875

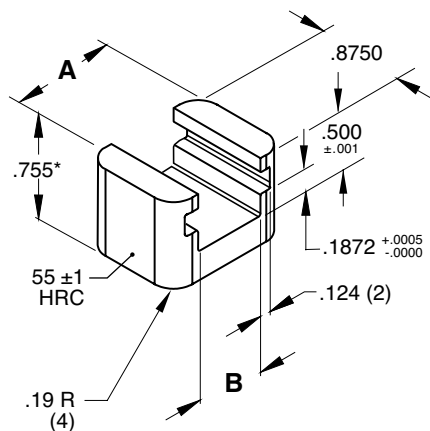
APPLICATION GUIDELINES

- Assembly length cap screw (#10-32 x 4") and Dowel Pin is included with each Gib Coupling, sold separately below.
- Install the assembly screw in the Gib Coupling as shown.
- Connect the lifter pin and pull unit into pocket in ejector plate, removing the screw afterwards.
- Lifter Guides are shown on page H-10.



▶ CAD insertion point

GIB COUPLINGS



M S-7 **H** 54-56 HRC **S** Salt Bath Nitride

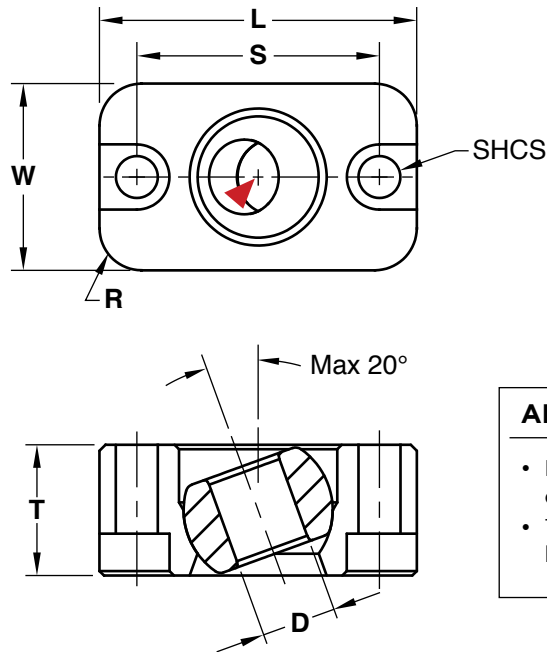
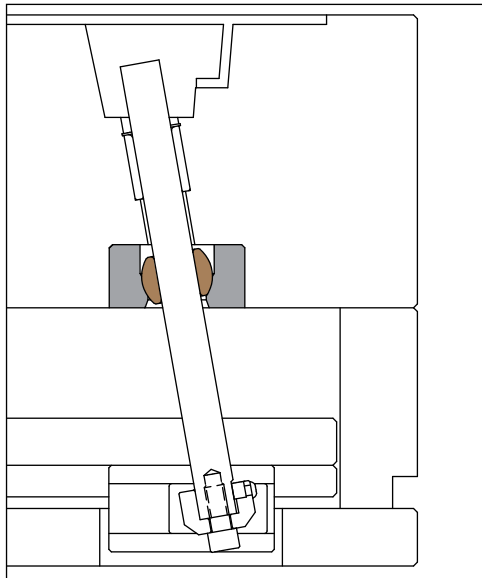
CATALOG NUMBER	A CENTRAL	B +.001 -.000	COMPATIBLE CORE BLADE WIDTHS (W)
UGV68	.6860	.190	.1875 & .4375
UGV87	.8735	.377	.6250
UGV112	1.1235	.627	.8750
UGV137	1.3735	.877	1.1250

* .005" stock is included on the bottom for fitting.
Includes #10-32 x 4" long screw.



LIFTER ACCESSORIES

SPHERICAL BUSHINGS



APPLICATION GUIDELINES

- Machine pocket with clearance on length and width.
- Tighten bolts after inserting lifter rod.

Housing: **M** 1045 **H** 18-22 HRC **S** Black Oxide

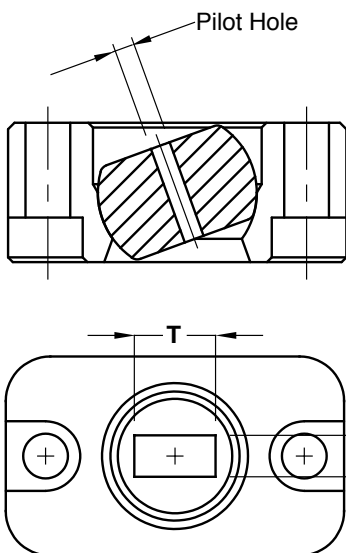
Bushing: **M** C86300 Bronze

▶ CAD insertion point

CATALOG NUMBER	D +.001 -.000	L +.000 -.002	W +.000 -.002	T +.000 -.002	S ±.005	R POCKET RADIUS	SHCS
LSB050	.5005	2.000	1.250	.875	1.500	.250	1/4-20 x 1
LSB063	.6255	2.250	1.500	1.125	1.750	.250	1/4-20 x 1-1/4
LSB075	.7505	2.625	1.750	1.375	2.125	.375	5/16-18 x 1-1/2
LSB100	1.0005	2.875	2.125	1.500	2.375	.375	5/16-18 x 1-3/4
LSB125	1.2505	4.000	2.750	2.000	3.250	.500	3/8-16 x 2-1/4
LSB150	1.5005	4.250	3.000	2.375	3.500	.500	3/8-16 x 2-3/4

Screws included.

BLANK SPHERICAL BUSHINGS



To Order Blanks:

Add "-B" to the end of the part number. Ex: LSB100-B

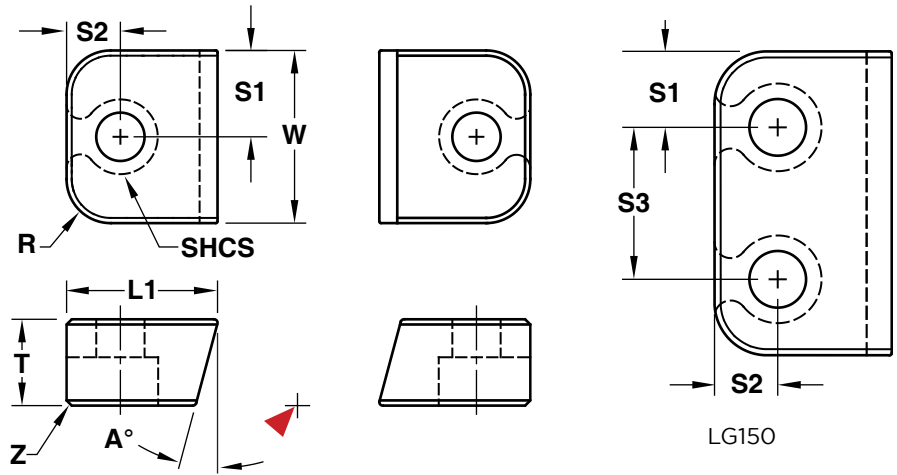
- Sizes 075-B and smaller have a .23" Pilot Hole.
- Sizes 100-B and larger have a .47" Pilot Hole.

Use the blank bushing to cut alternative core blade sizes. See chart for recommended sizing.

SPHERICAL BUSHING SIZE	LIFTER T X W (MAX)	UNILIFTER SIZE CHART
LSB050	1/2 X 1/2	CBS37X25, CBS50X25, CBS50X50, CBS43D, CBV50X18, CBV50X43, CBMM10D, CBMM10X10
LSB063	5/8 X 5/8	CBV50X62, CBMM15D, CBMM15X15
LSB075	3/4 X 3/4	CBS75X37, CBMM20X10, CBMM20X20
LSB100	1 X 1	CBS100X50, CBS100X100, CBS75D, CBV50X87
LSB125	1-1/4 X 1-1/4	CBS125D, CBV50X112, CBMM30X15
LSB150	1-1/2 X 1-1/2	CBS150X150, CBS150X75, CBS150X100

LIFTER ACCESSORIES

LIFTER GUIDES



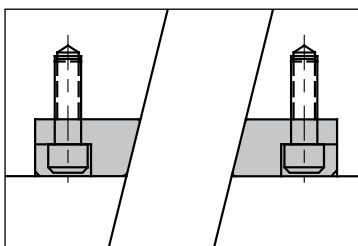
M O-1 **H** 58-60 HRC **S** Black Oxide

▶ CAD insertion point

W +.000 -.001	CATALOG NUMBER			T ±.015	L1	S1 ±.01	S2 ±.01	S3 ±.01	R POCKET RADIUS	Z CHAMFER	SHCS
	A=5°	A=10°	A=15°								
.375	LG37-5	LG37-10	LG37-15	.500	.500	.18	.18	--	.125	.02	#6-32 x 1/2
.500	LG50-5	LG50-10	LG50-15		.750	.25	.25	--	.187		.03
.750	LG75-5	LG75-10	LG75-15		.50	.37	--	--	.250	1/4-20 x 3/4	
1.000	LG100-5	LG100-10	LG100-15		.875	.50	.31	--	.250		
1.500	LG150-5	LG150-10	LG150-15			.37	.31	.75	.250		

Lifter Guides are sold in sets with Socket Head Cap Screws included.
LG150 items have 4 screws as shown in the locations below.

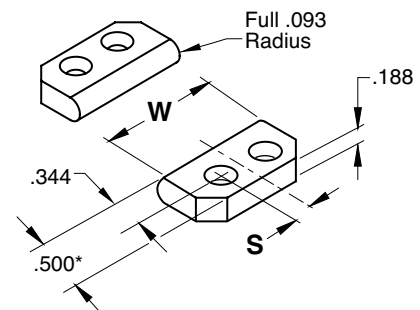
SIZE OF GUIDE	CAN BE USED WITH UNILIFTER CORE BLADE SIZE	MAX BLADE WIDTH (FOR OTHER SYSTEMS)
LG37	37X25 50X25 75X37	.385
LG50	50X50 75X50 100X50 150X50	.510
LG75	150X75	.760
LG100	100x100 150x100	1.010
LG150	50X150 75X150 100X150	1.510



VERSA-LIFTER GUIDES

APPLICATION GUIDELINES

- *Includes .005" fit stock on flat side.
- Sold in sets.
- Four (4) #6-32 LHCS are included.



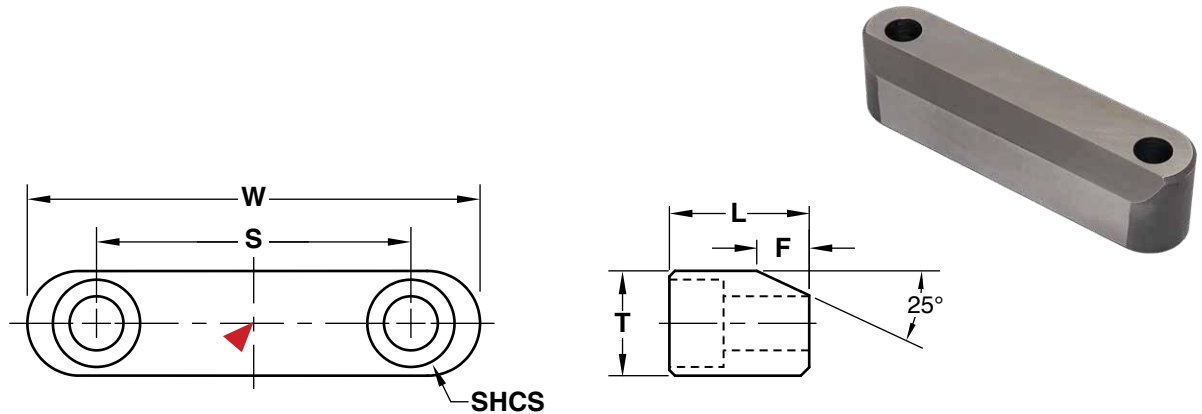
M S-7 **H** 54-56 HRC

CATALOG NUMBER	W	S
SGV43	.436	On Center
SGV62	.624	On Center
SGV87	.874	.187
SGV112	1.124	.312



LIFTER ACCESSORIES

LIFTER HEAD KEY

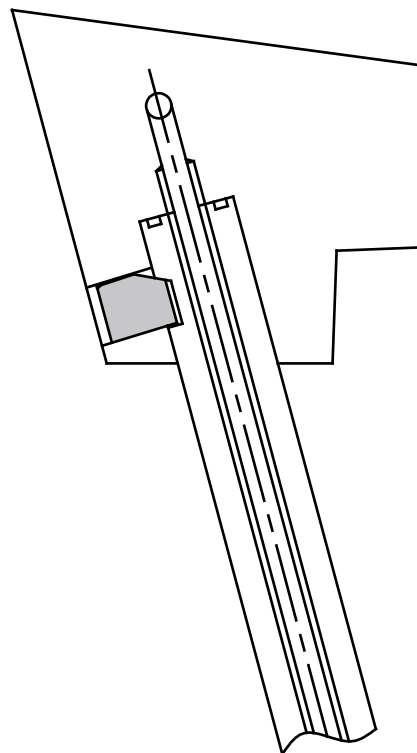


M 4140 **H** 28-32 HRC

▶ CAD insertion point

CATALOG NUMBER	NOMINAL ROD DIAMETER	W +.00 -.01	L ±.005	T +.000 -.005	F	S ±.01	SHCS
LHK050	1/2	1.370	.500	.375	.19	.87	#6-32 x 1/2
LHK063	5/8	1.495	.500	.375	.19	1.00	#6-32 x 1/2
LHK075	3/4	1.620	.500	.500	.19	1.12	#8-32 x 1/2
LHK100	1	1.870	.500	.500	.19	1.37	#8-32 x 1/2
LHK125	1-1/4	2.620	.750	.625	.25	2.00	1/4-20 x 7/8
LHK150	1-1/2	2.870	.750	.625	.25	2.25	1/4-20 x 7/8

Screws included.

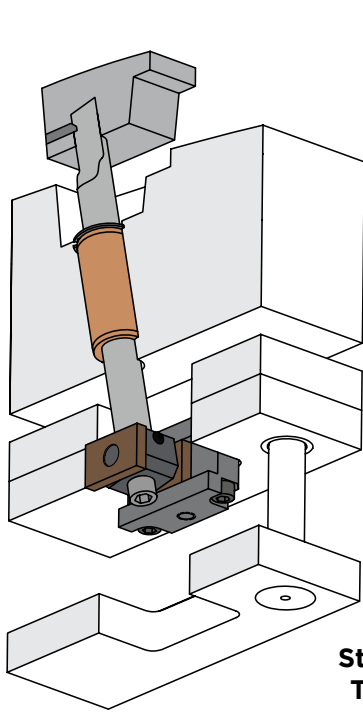


MODULIFTER[®]

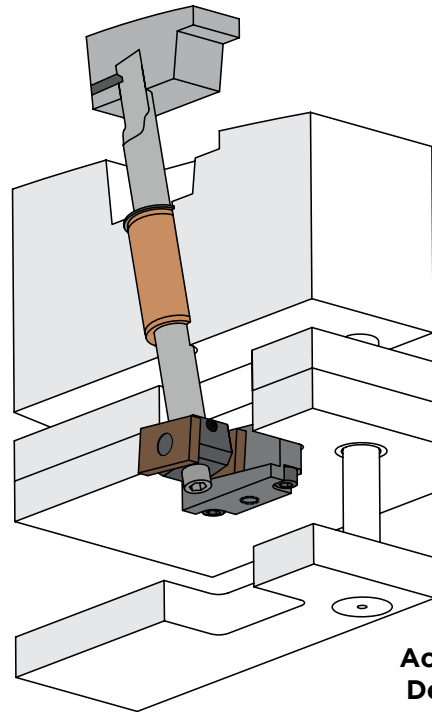
UNDERCUT RELEASE SYSTEM

A standardized modular lifter assembly simplifies undercut release:

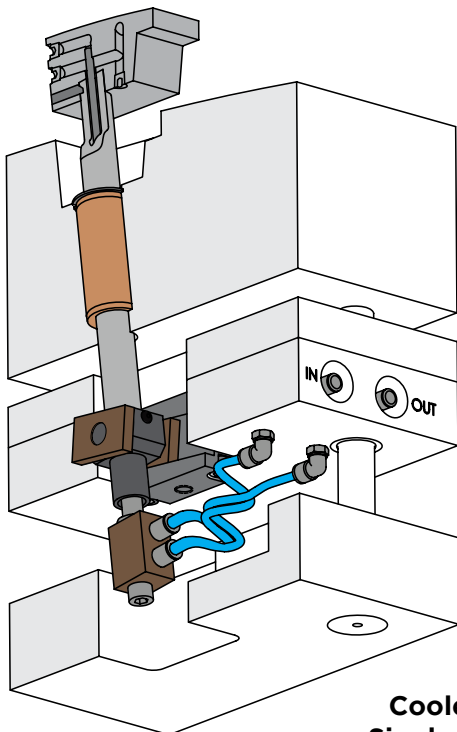
- Specialized design for accelerated and decelerated applications.
- Additional lifter cooling options and components available.



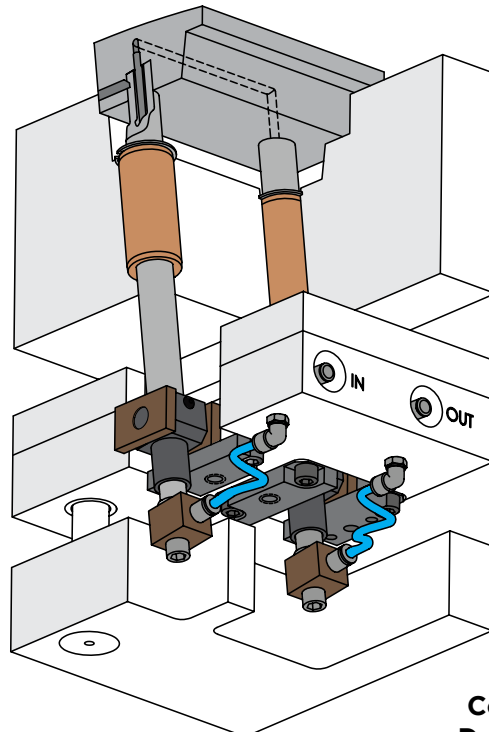
**Straight
Travel**



**Accelerated/
Decelerated
Options**



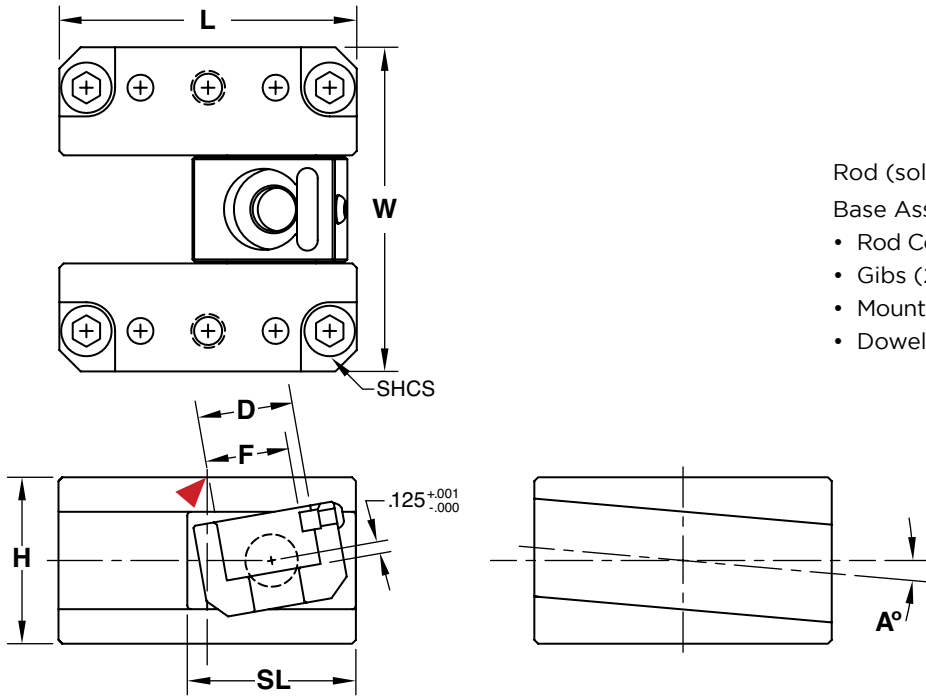
**Cooled:
Single Rod
In/Out**



**Cooled:
Dual Rod
In/Out**



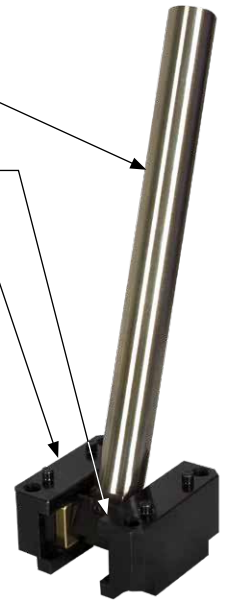
MODULIFTER® STANDARD ASSEMBLY



Rod (sold separately)

Base Assembly includes:

- Rod Coupling Assembly
- Gibs (2)
- Mounting Screws (4)
- Dowels installed



BASE ASSEMBLY

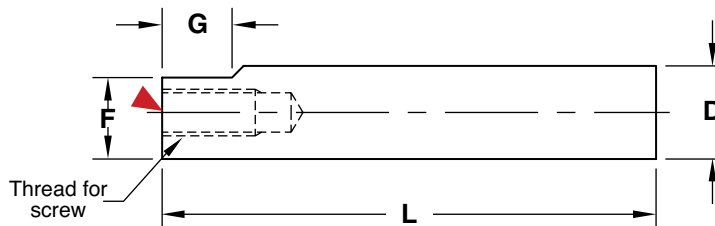
Gibs/Coupling: **M** 1045 **H** 28-32 HRC **S** Nitride Slides: **M** C86300 Bronze

▶ CAD insertion point

NOMINAL ROD DIAMETER	CATALOG NUMBER			L +.000 -.015	W +.000 -.002	H +.000 -.001	D +.0003 -.0000	F +.0015 -.0000	SHCS	SL	TRAVEL (L-SL)
	A=0°	A=5°	A=10°								
1/2	MLBA050	MLBA050-5	MLBA050-10	2.250	2.250	1.375	.5003	.4505	1/4-20 x 1-1/2	1.38	.87
5/8	MLBA063	MLBA063-5	MLBA063-10	2.625	2.500	1.375	.6253	.5905	1/4-20 x 1-1/2	1.57	1.06
3/4	MLBA075	MLBA075-5	MLBA075-10	2.750	3.000	1.750	.7503	.6905	5/16-18 x 2	1.57	1.18
1	MLBA100	MLBA100-5	MLBA100-10	3.125	3.250	1.750	1.0003	.8755	5/16-18 x 2	1.77	1.35
1-1/2	MLBA150	MLBA150-5	MLBA150-10	4.750	4.250	2.500	1.5003	1.4005	3/8-16 x 2-3/4	3.15	1.60

Includes (4) Socket Head Cap Screws and (4) Dowels.

LIFTER ROD



M 1045 **H** Core: 28-32 HRC, Surface: 56-58 HRC

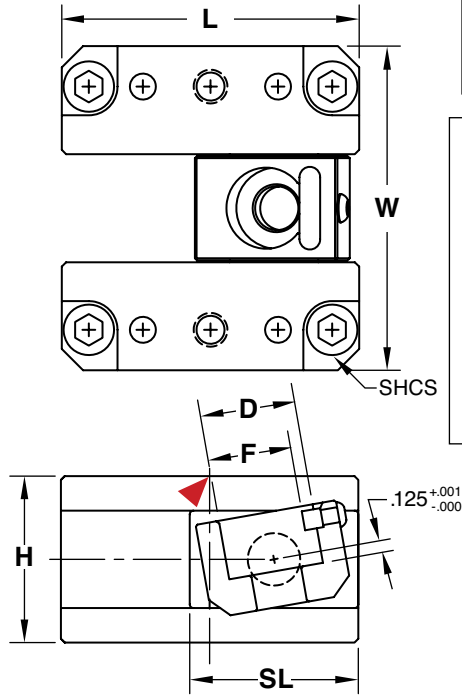
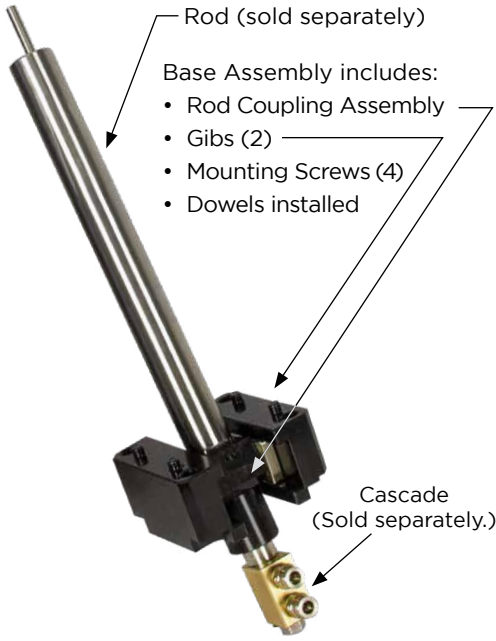
D +.0000 -.0003	CATALOG NUMBER	L +.13 -.00	F +.000 -.001	G +.03 -.00	SCREW SIZE
.500	MLR050L14	14	.450	.50	1/4-20 x 5/8
.625	MLR063L14	14	.590	.56	5/16-18 x 3/4
.750	MLR075L16	16	.690	.68	3/8-16 x 7/8
1.000	MLR100L16	16	.875	.75	1/2-13 x 1
1.500	MLR150L18	18	1.400	1.00	5/8-11 x 1-1/2

▶ CAD insertion point

APPLICATION GUIDELINES

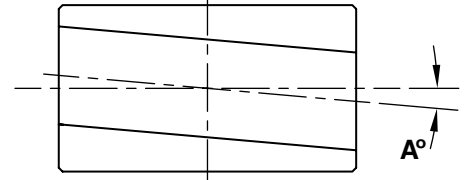
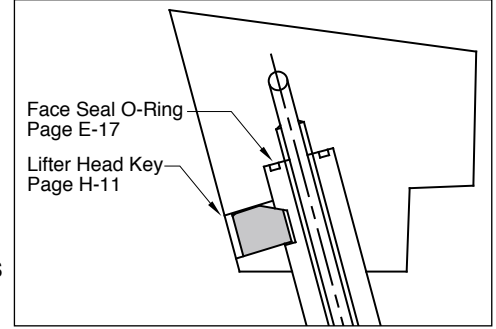
- Includes (1) Socket Head Cap Screw for installation.
- For additional Lifter Rod lengths, contact tech@procomps.com.

MODULIFTER®
COOLED ASSEMBLY



APPLICATION GUIDELINES

- The ModuLifter Cooling Base Assemblies have three (3) options for varying water connections.
- Additional accessories are shown below.



COOLED BASE ASSEMBLY

Gibs/Coupling: **M** 1045 **H** 28-32 HRC **S** Nitride

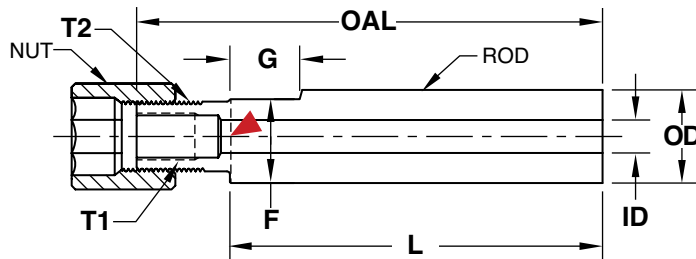
Slides: **M** C86300 Bronze

CAD insertion point

NOMINAL ROD DIAMETER	CATALOG NUMBER			L +.000 -.015	W +.000 -.002	H +.000 -.001	D +.0003 -.0000	F +.0015 -.0000	SHCS	SL	TRAVEL (L-SL)
	A=0°	A=5°	A=10°								
5/8	MLCBA063	MLCBA063-5	MLCBA063-10	2.625	2.500	1.375	.6253	.5905	1/4-20 x 1-1/2	1.57	1.06
3/4	MLCBA075	MLCBA075-5	MLCBA075-10	2.750	3.000	1.750	.7503	.6905	5/16-18 x 2	1.57	1.18
1	MLCBA100	MLCBA100-5	MLCBA100-10	3.125	3.250	1.750	1.0003	.8755	5/16-18 x 2	1.77	1.35
1-1/2	MLCBA150	MLCBA150-5	MLCBA150-10	4.750	4.250	2.500	1.5003	1.4005	3/8-16 x 2-3/4	3.15	1.60

Includes (4) Socket Head Cap Screws and (4) Dowels.

COOLED LIFTER ROD



M 1045 **H** Core: 28-32 HRC, Surface: 56-58 HRC

CAD insertion point

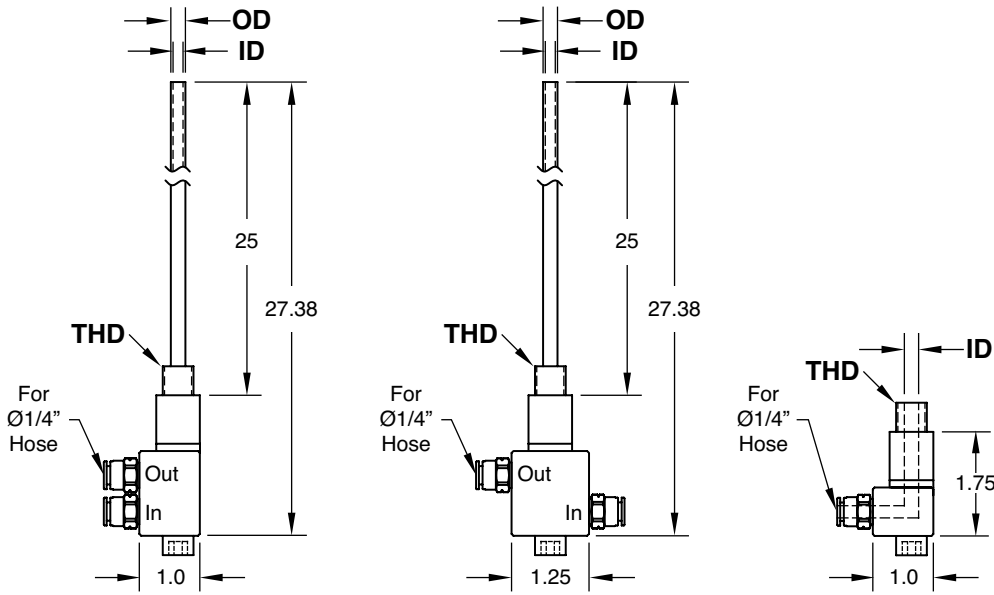
OD +.0000 -.0003	CATALOG NUMBER	ID	OAL	L +.13 -.00	T1 INTERNAL THREAD	T2 EXTERNAL THREAD	G +.03 -.00	F +.000 -.001
.625	MLCR063L14	.250	14.75	14	5/16-24	1/2-20	.56	.590
.750	MLCR075L16	.250	16.88	16	5/16-24	1/2-20	.68	.690
1.000	MLCR100L16	.375	17.00	16	1/2-20	3/4-20	.75	.875
1.500	MLCR150L18	.375	19.38	18	1/2-20	7/8-20	1.00	1.400

APPLICATION GUIDELINES

- Includes (1) Installation Nut. Replacement nuts are available.
- For additional Cooled Lifter Rod lengths, contact tech@procomps.com.



MODULIFTER® COOLING CASCADES

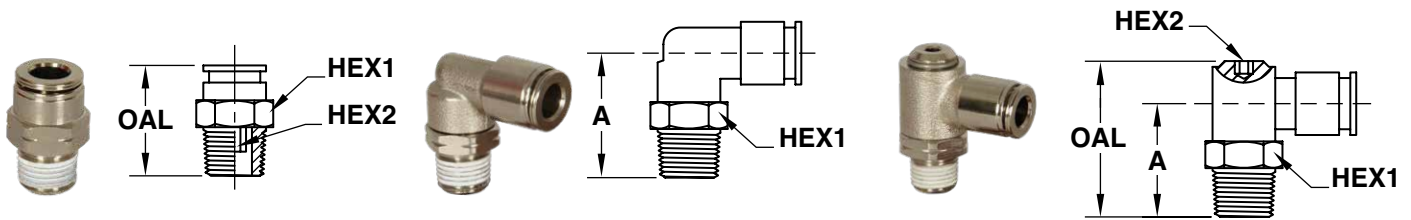


M C86300 and Stainless Steel. Fittings: Nickel Plated Brass.

PARALLEL (IN & OUT)			SERIES (IN & OUT)			SINGLE (IN ONLY)		THD	MAX TORQUE	NOMINAL ROD DIAMETER
OD	ID	CATALOG NUMBER	OD	ID	CATALOG NUMBER	ID	CATALOG NUMBER			
.157	.12	MLCP16L25	.157	.12	MLCS16L25	.12	MLC12	5/16-24	75 in-lbs	5/8, 3/4
.236	.20	MLCP23L25	.236	.20	MLCS23L25	.20	MLC20	1/2-20	20 ft-lbs	1, 1-1/2

- Straight Fittings included with Cooling Cascades.
- Replacement O-Rings available. Specify MLC312-OR (for .12 ID) or MLC500-OR (for .20 ID).

PUSH-TO-CONNECT HOSE FITTINGS



M Nickel Plated Brass with Sealant

FITTING TYPE	CATALOG NUMBER	HOSE OD	THD (NPT)	HEX1	HEX2	A	OAL
Straight	MLFS25	1/4	1/8	1/2	5/32	—	.87
Elbow	MLFE25	1/4	1/8	1/2	—	.83	—
Banjo	MLFB25	1/4	1/8	9/16	1/8	.81	1.22

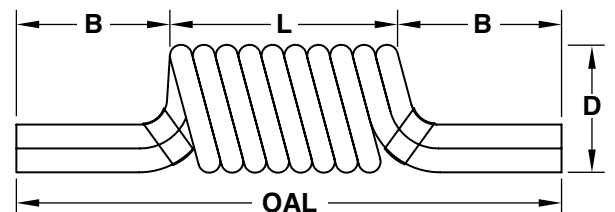
Maximum Operating Temperature 160° F (70°C)

PUSH-TO-CONNECT SPIRAL AND STRAIGHT HOSES

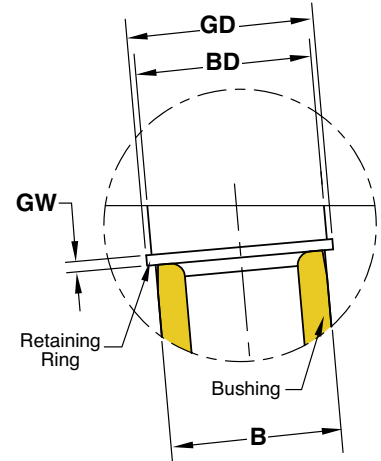
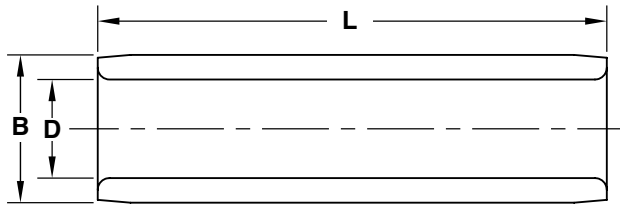
M Polyurethane

CATALOG NUMBER	HOSE OD	HOSE ID	TURNS	OAL	L	B	D
MLH25-5	1/4	5/32	5	10.5 in	2.5	4	1.5
MLH25-10	1/4	5/32	10	13.0 in	5.0	4	1.5
MLH25-25	1/4	5/32	Straight	25.0 ft	—	—	—

Maximum Operating Temperature 160°F (70°C).



MODULIFTER®
LIFTER ROD BUSHING



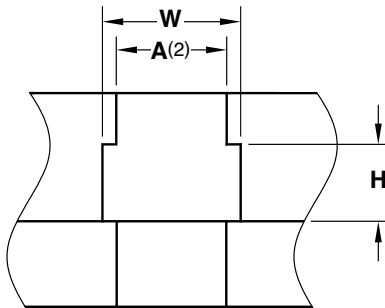
Bushings: **M** C95400

Retaining Ring: **M** Steel **S** Black Oxide

CATALOG NUMBER	D +.001 -.000	B +.0005 -.0000	L +.00 -.01	GD +.005 -.000	GW +.005 -.000	BD ± .002
MLBSH50L1.37	.5005	.750	1.375	.862	.046	.813
MLBSH63L1.37	.6255	.875	1.375	1.000	.046	.934
MLBSH75L3.37	.7505	1.125	3.375	1.262	.056	1.188
MLBSH100L4.37	1.0005	1.375	4.375	1.528	.056	1.438
MLBSH150L5.87	1.5005	2.000	5.875	2.186	.086	2.063

Includes (1) Retaining Ring. Replacement Retaining Rings are available.
To order, specify the prefix of RR before the ID. Ex. RR50 for a 1/2 ID ring.

ROD COUPLING ASSEMBLY PLATE MACHINING OPTION

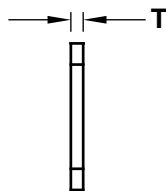
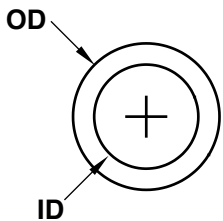


Coupling: **M** 1045 **H** 28-32 HRC **S** Nitride

Slides: **M** C86300 Bronze

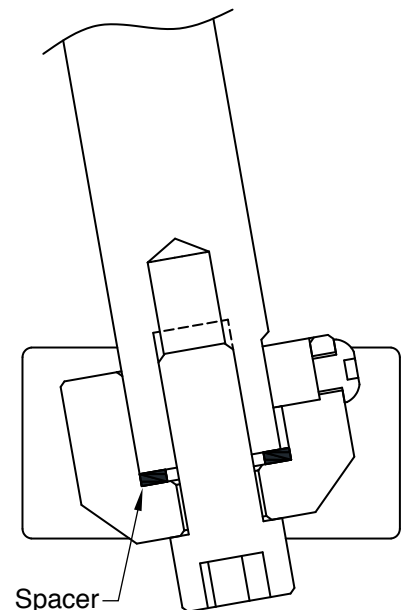
NOMINAL ROD DIAMETER	CATALOG NUMBER		W +.002 -.000	H ± .001	A +.010 -.000
	NON-COOLED	COOLED			
1/2	RC050	—	1.187	.788	.66
5/8	RC063	RCC063	1.310	.788	.78
3/4	RC075	RCC075	1.500	.946	.97
1	RC100	RCC100	1.781	1.024	1.21
1-1/2	RC150	RCC150	2.656	1.498	1.84

LIFTER ROD SPACER



M D-2 **H** 58-60 HRC

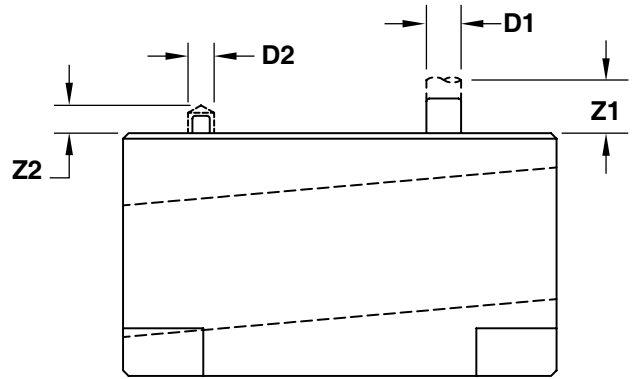
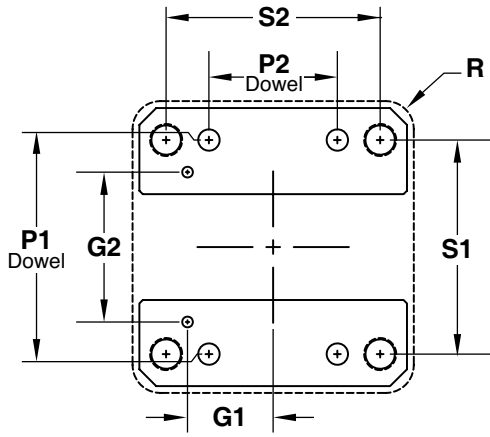
CATALOG NUMBER	OD +.00 -.01	ID +.000 -.005	T +.000 -.001
MLRS050	.500	.30	.063
MLRS063	.625	.53	
MLRS075	.750	.53	
MLRS100	1.000	.80	
MLRS150	1.500	.93	





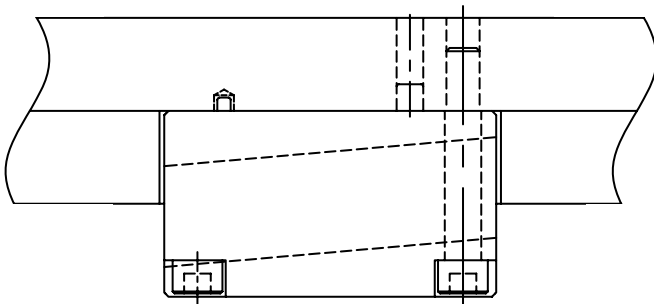
MODULIFTER®

INSTALLATION GUIDELINES FOR BASE ASSEMBLIES

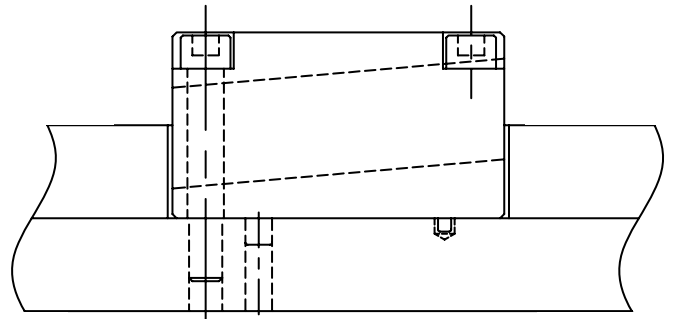


INSTALLATION DIMENSIONS							ACCEL./DECEL. KEYING DOWEL				
NOMINAL ROD DIAMETER	S1 ± .01	S2 ± .01	P1 DOWEL ±.0005	P2 DOWEL ±.0005	R POCKET MAX	D1 +.0005 -.0000	Z1 +.03 -.00	G1 ± .005	G2 ± .005	D2 DRILL DIA.	Z2 DRILL DEPTH +.03/-0.00
1/2	1.75	1.75	1.750	.750	.19	.2500	.28	.75	1.00	.125	.19
5/8	2.00	2.00	2.000	1.000							
3/4	2.25	2.25	2.250	1.250							
1	2.50	2.50	2.500	1.500	.25	.3750	.41	1.00	1.75	.188	.23
1-1/2	3.50	4.00	3.500	2.500							

INSTALLATION METHODS

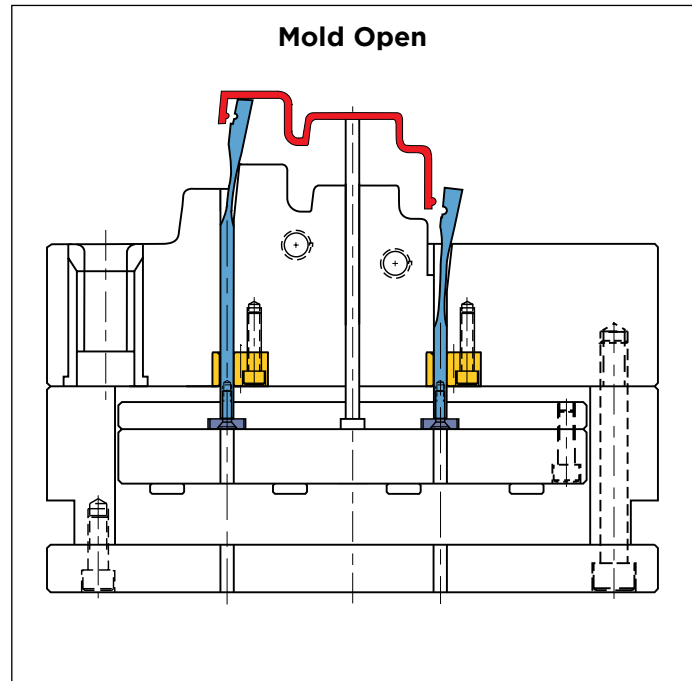
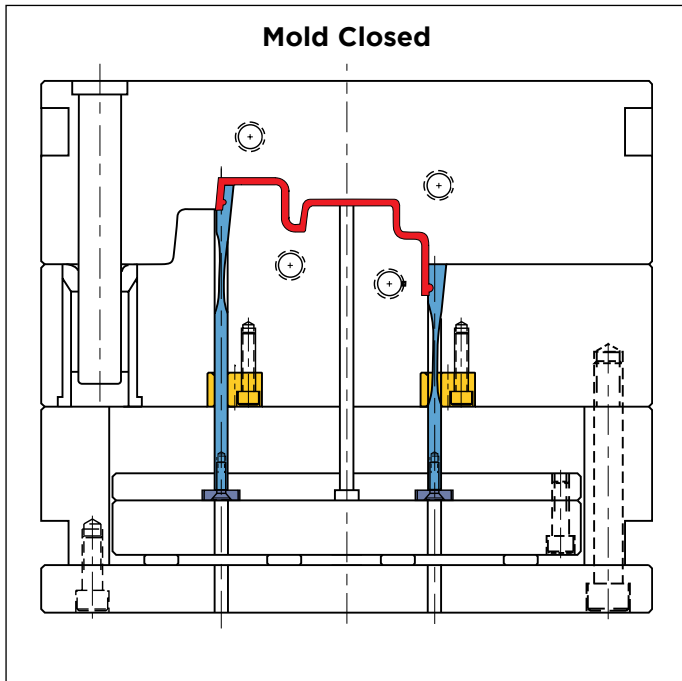
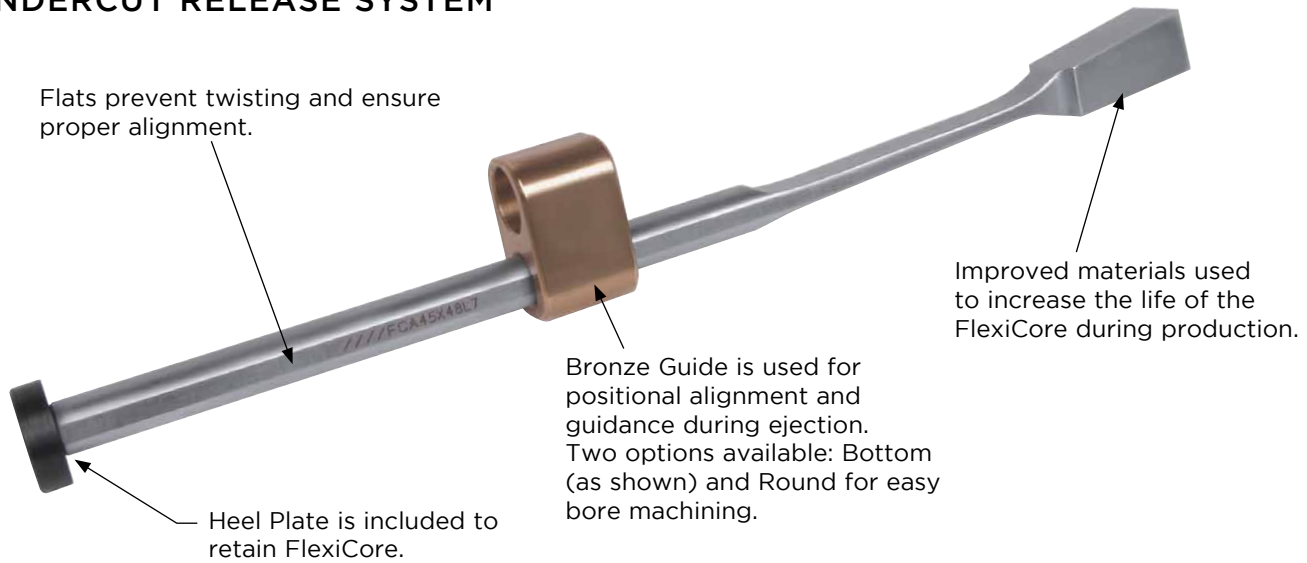


Bottom Mount



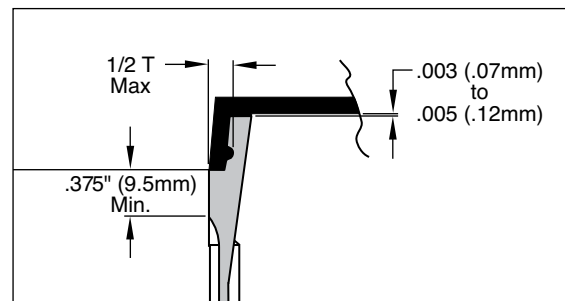
Top Mount

FLEXICORE™ UNDERCUT RELEASE SYSTEM



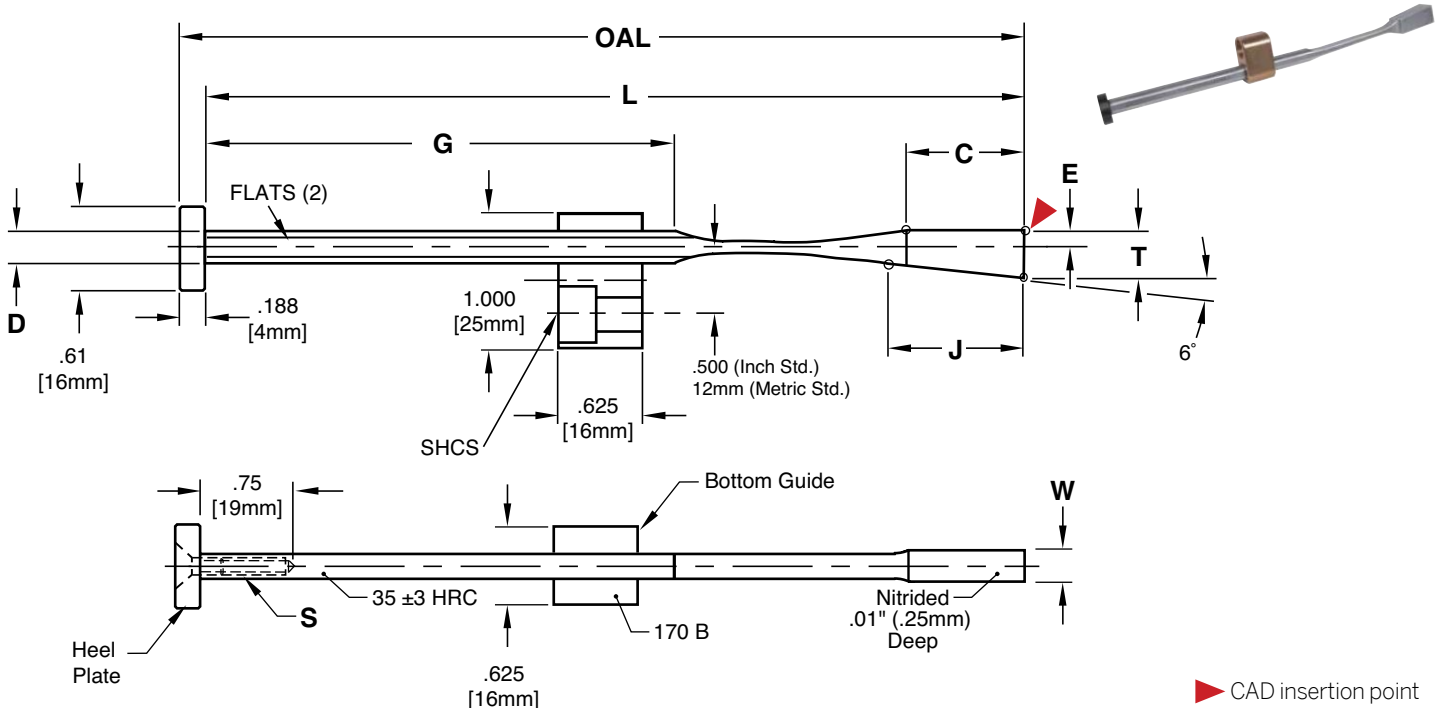
APPLICATION GUIDELINES

- The FlexiCore diameter (D) must be within the Guide prior to ejection as shown above.
- Only surface treatments applied at low temperatures such as Electroless Nickel-based or chromium deposition treatments are permitted.
- Maximum temperature is 250°F (125°C).
- FlexiCore Assembly includes: FlexiCore, Bronze Guide (Bottom or Round), Heel Plate, and Flat Head Cap Screw.
- Please contact tech@procomps.com to review any designs if questions arise or if your application differs from the examples shown.





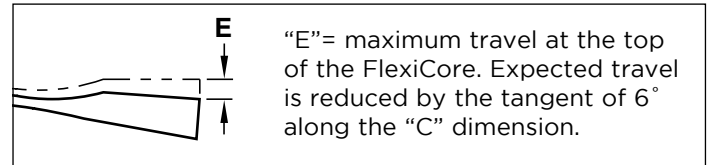
FLEXICORE™ BOTTOM GUIDE ASSEMBLY



▶ CAD insertion point

APPLICATION GUIDELINES

- The FlexiCore can be cut down and re-tapped to accommodate specific applications.
- Assemblies include FlexiCore, Bottom Guide, Heel Plate, and Flat Head Cap Screw.
- Assembly components also sold individually on page H-23.



Inch Standard

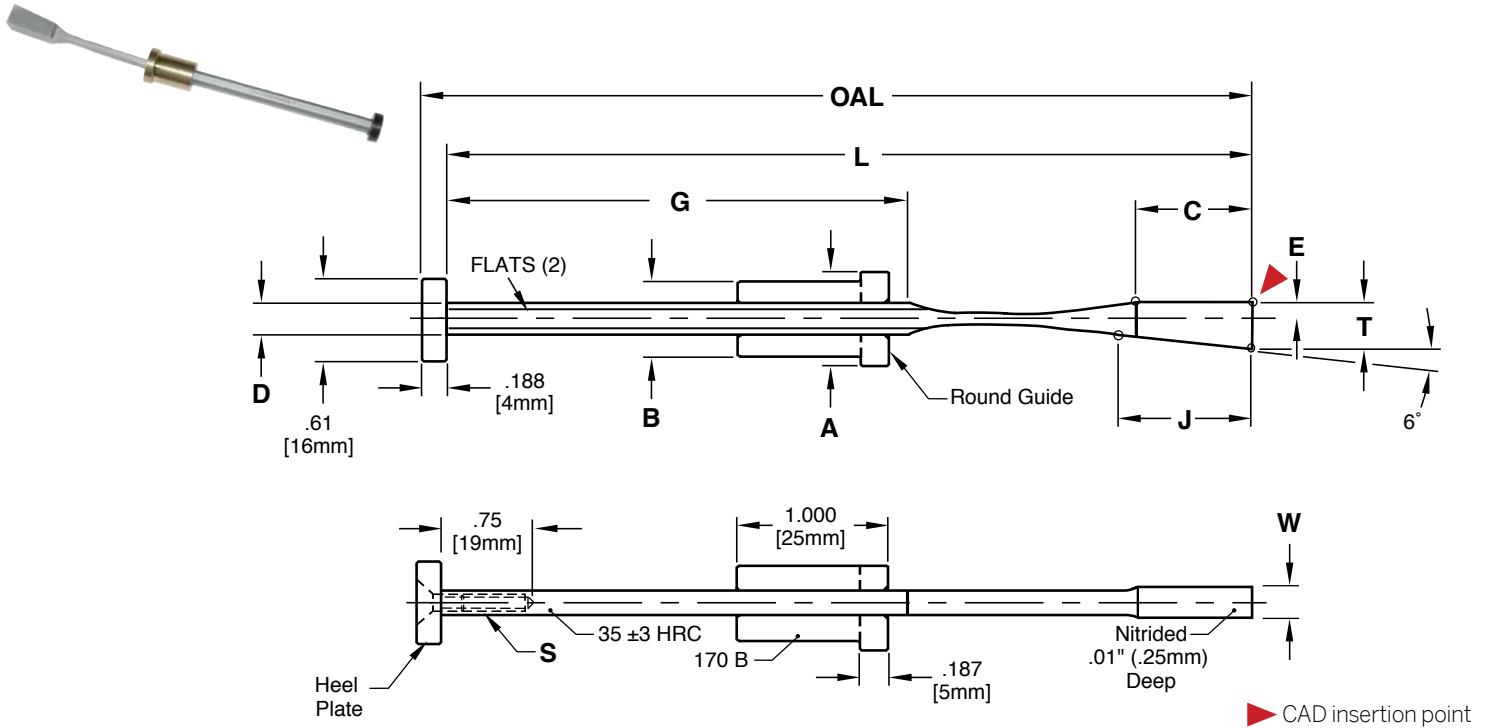
M FlexiCore: AISI 4340 with thin, dense Chromium treatment, Guide: CA954 Solid Bronze, Heel Plate: AISI 1018

CATALOG NUMBER	T +.002 -.000	W +.002 -.000	L +.010 -.000	OAL REF	D +.000 -.001	C ±.015	E	G +.01 -.00	J	S (INCLUDED)	SHCS
FCA35X24L6	.354	.244	6.400	6.588	.234	.875	.137	3.49	.957	#8-32 x 3/8	1/4-20
FCA35X32L6	.354	.322	6.400	6.588	.250	.875	.137	3.48	.957	#8-32 x 3/8	1/4-20
FCA45X40L7	.453	.401	7.875	8.062	.312	1.000	.177	4.38	1.025	#10-24 x 1/2	1/4-20
FCA45X48L7	.453	.480	7.875	8.062	.312	1.000	.177	4.38	1.025	#10-24 x 1/2	1/4-20

Metric Standard

CATALOG NUMBER	T +.05 -.00	W +.05 -.00	L +.25 -.00	OAL REF	D +.000 -.025	C ±.35	E	G +.25 -.00	J	S (INCLUDED)	SHCS
FCA9X6L160	9	6.2	162.5	166.5	5.94	22	3.5	88.6	24.3	M4-0.7 x 12	M6-1
FCA9X8L160	9	8.2	162.5	166.5	6.35	22	3.5	88.4	24.3	M4-0.7 x 12	M6-1
FCA11X10L200	11.5	10.2	200.0	204.0	7.92	26	4.5	111.2	26.0	M5-0.8 x 14	M6-1
FCA11X12L200	11.5	12.2	200.0	204.0	7.92	26	4.5	111.2	26.0	M5-0.8 x 14	M6-1
FCA12X14L200	12.5	14.2	200.0	204.0	7.92	30	4.5	107.2	28.5	M5-0.8 x 14	M6-1
FCA12X16L200	12.5	16.2	200.0	204.0	7.92	30	4.5	107.2	28.5	M5-0.8 x 14	M6-1

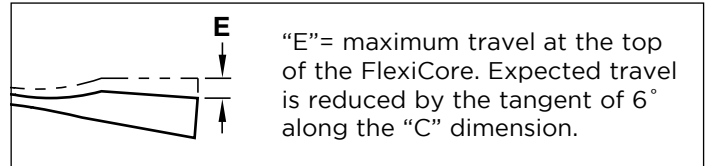
FLEXICORE™ ROUND GUIDE ASSEMBLY



▶ CAD insertion point

APPLICATION GUIDELINES

- The FlexiCore can be cut down and re-tapped to accommodate specific applications.
- Assemblies include FlexiCore, Round Guide, Heel Plate, and Flat Head Cap Screw.
- Assembly components also sold individually on page H-23.



Inch Standard

M FlexiCore: AISI 4340 with thin, dense Chromium treatment, Guide: CA954 Solid Bronze, Heel Plate: AISI 1018

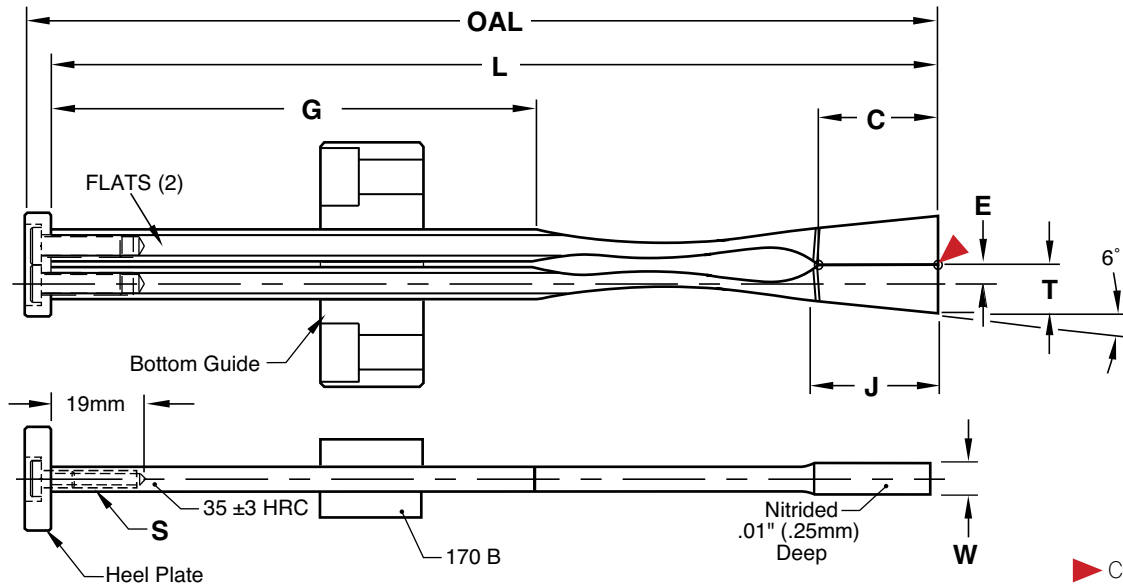
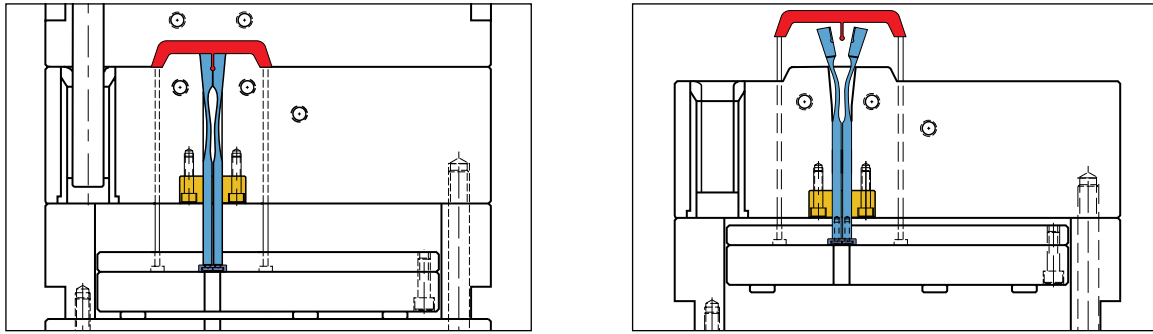
CATALOG NUMBER	T +.002 -.000	W +.002 -.000	L +.010 -.000	OAL REF	D +.000 -.001	C ± .015	E	G +.01 -.00	J	S (INCLUDED)	A	B
FCR35X24L6	.354	.244	6.400	6.588	.234	.875	.137	3.49	.957	#8-32 x 3/8	.625	.500
FCR35X32L6	.354	.322	6.400	6.588	.250	.875	.137	3.48	.957	#8-32 x 3/8	.625	.500
FCR45X40L7	.453	.401	7.875	8.062	.312	1.000	.177	4.38	1.025	#10-24 x 1/2	.750	.625
FCR45X48L7	.453	.480	7.875	8.062	.312	1.000	.177	4.38	1.025	#10-24 x 1/2	.750	.625

Metric Standard

CATALOG NUMBER	T +.05 -.00	W +.05 -.00	L +.25 -.00	OAL REF	D +.000 -.025	C ±.35	E	G +.25 -.00	J	S (INCLUDED)	A	B
FCR9X6L160	9	6.2	162.5	166.5	5.94	22	3.5	88.6	24.3	M4-0.7 x 12	16	12
FCR9X8L160	9	8.2	162.5	166.5	6.35	22	3.5	88.4	24.3	M4-0.7 x 12	16	12
FCR11X10L200	11.5	10.2	200.0	204.0	7.92	26	4.5	111.2	26.0	M5-0.8 x 14	20	16
FCR11X12L200	11.5	12.2	200.0	204.0	7.92	26	4.5	111.2	26.0	M5-0.8 x 14	20	16
FCR12X14L200	12.5	14.2	200.0	204.0	7.92	30	4.5	107.2	28.5	M5-0.8 x 14	20	16
FCR12X16L200	12.5	16.2	200.0	204.0	7.92	30	4.5	107.2	28.5	M5-0.8 x 14	20	16

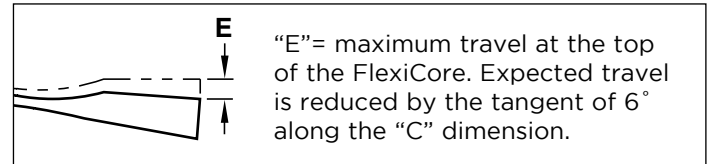


FLEXICORE™ DOUBLE ACTUATION



APPLICATION GUIDELINES

- The FlexiCore can be cut down and re-tapped to accommodate specific applications.
- Assemblies include two FlexiCores, one Bottom Guide, one Heel Plate, and two Low Head Cap Screws.
- Assembly components also sold individually on page H-23.



Inch Standard

M FlexiCore: AISI 4340 with thin, dense Chromium treatment, Guide: CA954 Solid Bronze, Heel Plate: AISI 1018

CATALOG NUMBER	T +.002 -.000	W +.002 -.000	L +.010 -.000	OAL REF	D +.000 -.001	C ±.015	E ±.015	G +.01 -.00	J +.01 -.00	S (INCLUDED-2)
FCDA35X24L6	.354	.244	6.400	6.588	.234	.875	.137	3.49	.957	#8-32 x 3/8
FCDA45X48L7	.453	.480	7.875	8.062	.312	1.000	.177	4.38	1.025	#10-24 x 1/2

Metric Standard

CATALOG NUMBER	T +.05 -.00	W +.05 -.00	L +.25 -.00	OAL REF	D +.000 -.025	C ±.035	E 015	G +.25 -.00	J +.01 -.00	S (INCLUDED-2)
FCDA9X6L160	9	6.2	162.5	166.5	5.94	22	3.5	88.6	24.3	M4-0.7 x 12
FCDA11X12L200	11.5	12.2	200.0	204.0	7.92	26	4.5	111.2	26.0	M5-0.8 x 14
FCDA12X14L200	12.5	14.2	200.0	204.0	7.92	30	4.5	107.2	28.5	M5-0.8 x 14
FCDA12X16L200	12.5	16.2	200.0	204.0	7.92	30	4.5	107.2	28.5	M5-0.8 x 14

FLEXICORE™ ACCESSORIES

WEAR BLOCKS

Inch Standard

M P-20 Pre-Hard **H** Nitrided .005" Deep

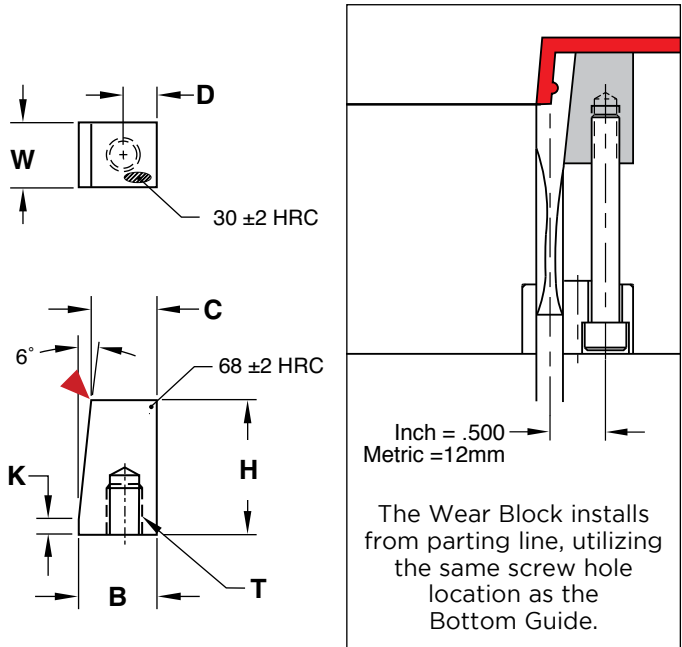
CATALOG NUMBER	W +.002 -.000	D ±.01	B +.001 -.000	C +.001 -.000	H	K	T THREAD
FCWB-24	.244	.250	.626	.533	1.000	.115	#10-24
FCWB-32	.322	.250	.626	.533	1.000	.115	1/4-20
FCWB-40	.401	.250	.567	.474	1.000	.115	1/4-20
FCWB-48	.480	.250	.567	.474	1.000	.115	1/4-20

Note: FCWB-24 is designed for use with a 1/4ø shoulder bolt.

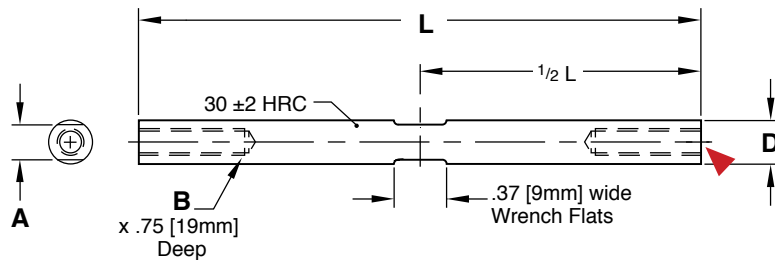
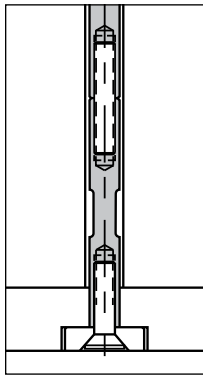
Metric Standard

CATALOG NUMBER	W +.05 -.00	D ±.25	B +.025 -.000	C +.025 -.000	H	K	T THREAD
FCWBM-6	6.2	7.2	15.9	13.55	25.4	2.9	M5-0.8
FCWBM-8	8.2	7.2	15.9	13.55	25.4	2.9	M6-1
FCWBM-10	10.2	7.2	14.4	12.05	25.4	2.9	M6-1
FCWBM-12	12.2	7.2	14.4	12.05	25.4	2.9	M6-1
FCWBM-14	14.2	8.0	15.2	12.11	33.2	3.5	M6-1
FCWBM-16	16.2	8.0	15.2	12.11	33.2	3.5	M6-1

▶ CAD insertion point



EXTENSIONS



Inch Standard

M 4140 Pre-Hard

D +.000 -.005	B	A	L +.01 -.00	
			2"	4"
.232	#8-32	.187	FCX8L2	FCX8L4
.310	#10-24	.250	FCX10L2	FCX10L4

Metric Standard

M 4140 Pre-Hard

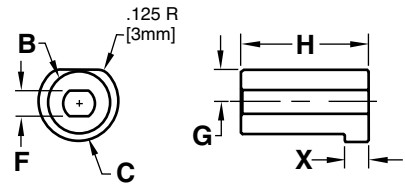
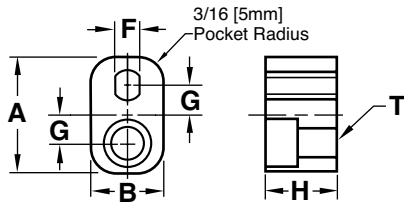
▶ CAD insertion point

D +.00 -.12	B	A	L +.25 -.00	
			50MM	100MM
6	M4-7	4.8	FCXM4L50	FCXM4L100
8	M5-8	6.3	FCXM5L50	FCXM5L100

Includes threaded stud for attachment to FlexiCore.



FLEXICORE™ ACCESSORIES REPLACEMENT GUIDES



Bottom Guides: Inch/Metric Standard

M CA954 Solid Bronze

CATALOG NUMBER	A	B	H	F	G	T
FCBG-24	1.000	.625	.625	.190	.250	1/4-20
FCBG-32	1.000	.625	.625	.200	.250	1/4-20
FCBG-40	1.000	.625	.625	.290	.250	1/4-20
FCBG-6	25	16	16	4.8	6	M6-1
FCBG-8	25	16	16	5.0	6	M6-1
FCBG-10	25	16	16	7.3	6	M6-1

Screws included.

Round Guides: Inch/Metric Standard

M CA954 Solid Bronze

CATALOG NUMBER	B	C	H	F	X	G
FCRG-24	.5000	.625	1.000	.190	.187	.250
FCRG-32	.5000	.625	1.000	.200	.187	.250
FCRG-40	.6250	.750	1.000	.290	.187	.312
FCRG-6	12	16	25	4.8	5	6
FCRG-8	12	16	25	5.0	5	6
FCRG-10	16	20	25	7.3	5	8

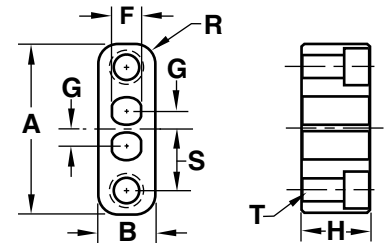
Screws included.

Double Actuation: Inch/Metric Standard

M CA954 Solid Bronze

CATALOG NUMBER	A	B	H	F	G	R	S	T
FCDBG-24	1.750	.625	.750	.190	.136	.218	.636	1/4-20
FCDBG-48	1.875	.625	.750	.290	.176	.218	.676	1/4-20
FCDBG-6	45	16	20	4.8	3.5	5	15.5	M6-1
FCDBG-12	48	16	20	7.3	4.5	5	16.5	M6-1

Screws included.



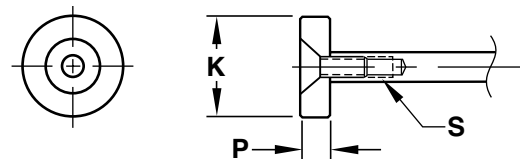
REPLACEMENT HEEL PLATES

Inch/Metric Standard

M 4140 Pre-Hard **H** Black Oxide

CATALOG NUMBER	K	P	S (INCLUDED)
FCHP-8	.61	.188	#8-32 x 3/8
FCHP-10	.61	.188	#10-24 x 1/2
FCHP-4	16	4	M4-0.7 x 12
FCHP-5	16	4	M5-0.8 x 14

Screws included.

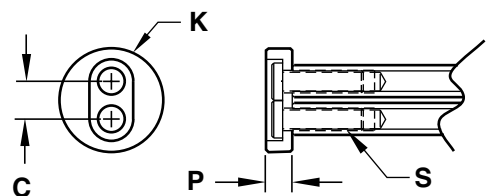


Double Actuation: Inch/Metric Standard

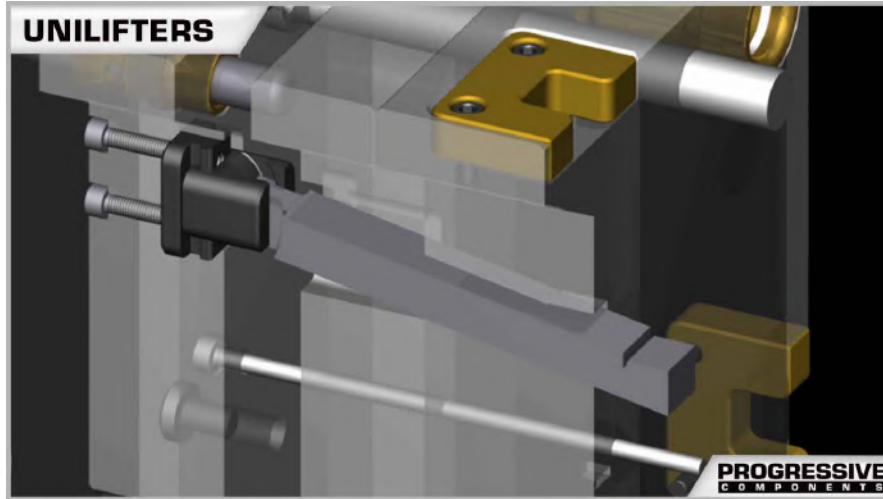
M 4140 Pre-Hard **H** Black Oxide

CATALOG NUMBER	C	K	P	S (INCLUDED)
FCDHP-8	.272	.750	.188	#8-32 x 3/8
FCDHP-10	.352	.875	.188	#10-24 x 1/2
FCDHP-4	7	20	6	M4-0.7 x 12
FCDHP-5	9	22	6	M5-0.8 x 14

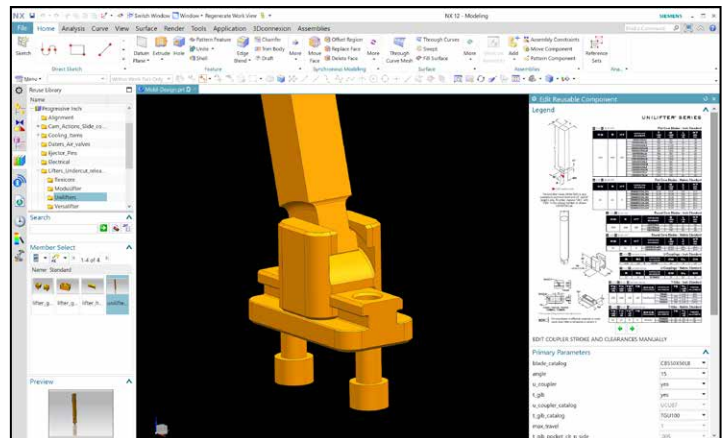
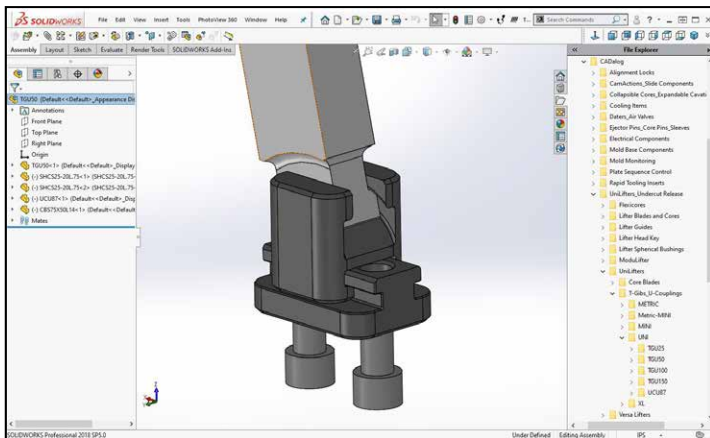
Screws included.



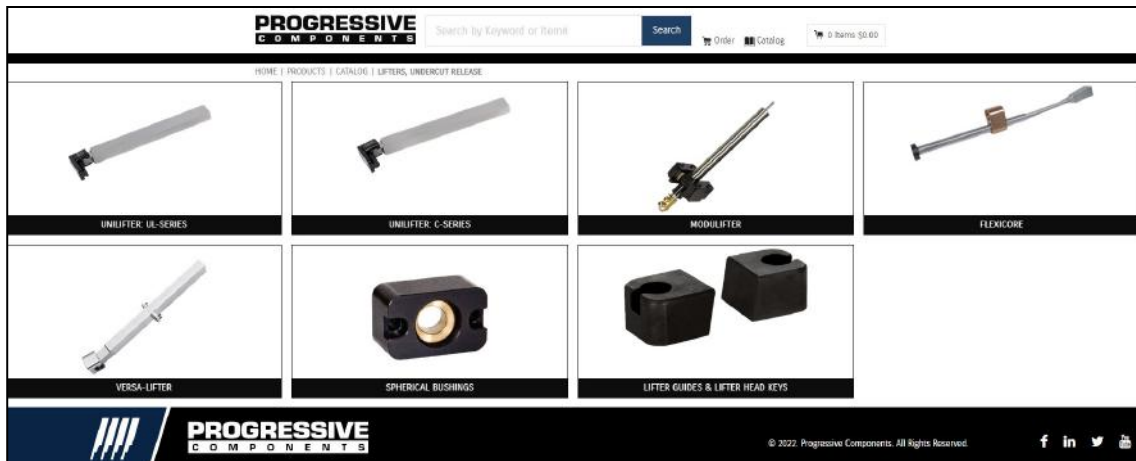
ONLINE RESOURCES



When considering design options, numerous animations can be viewed at procomps.com/animations.



CAD geometry is available online as individual downloads or as part of the CADalog system. The seven formats include: IGES (.igs), ACIS (.sat), STEP (.step), Parasolid (.x_t), SolidWorks (.sldasm), NX (.prt) (Re-Use and MoldWizard) and Visi (.wfk).



Industry-leading web store expedites the purchasing process. Go to shop.procomps.com for information and additional resources.



COLLAPSIBLE CORES EXPANDABLE CAVITIES

SECTION I



C-Cores: DT Series

Page: I-1

DT Core Grinding Fixtures

Page: I-2

DT Core Sub-10mm Series

Page: I-2



C-Cores: RT Series

Page: I-2

RT Core Grinding Rings

Page: I-2

Expandable Cavities

Page: I-3



COLLAPSIBLE CORES DT SERIES

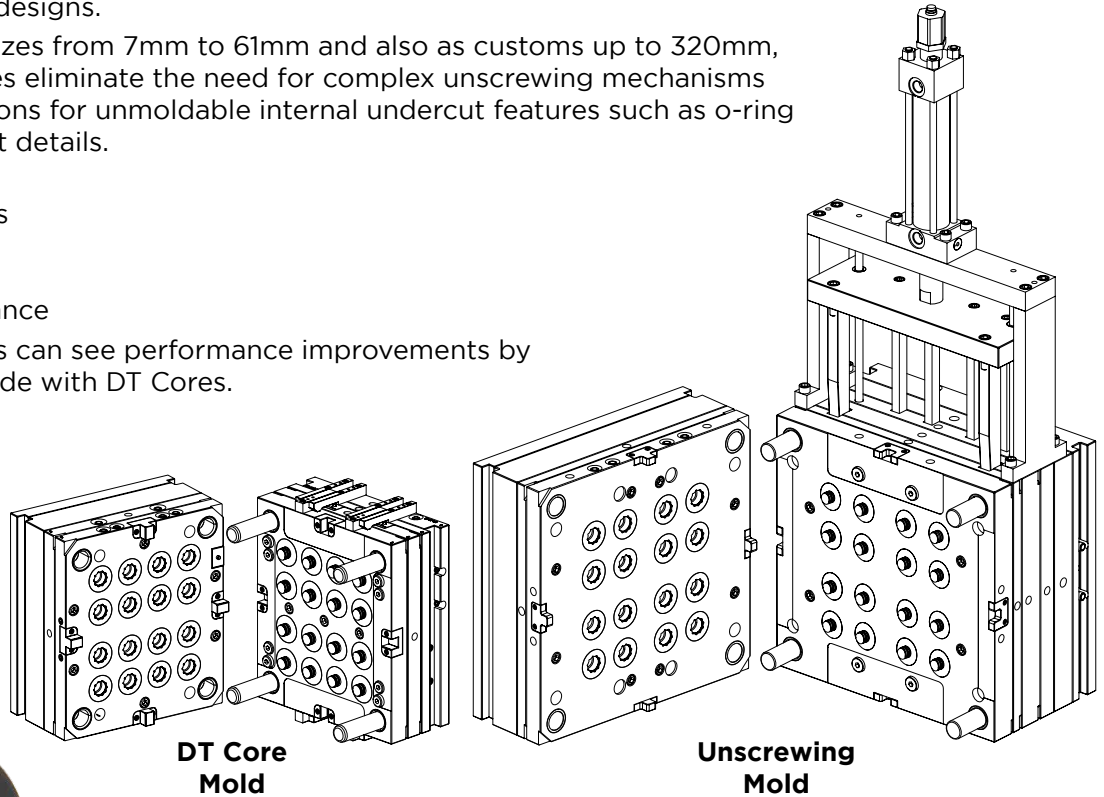
Roehr Tool Solutions offers several product options for molding and releasing threads. Dove Tail Collapsible Cores offer a more compact design and simplified mold approach over other tool designs.

Available in 24 standard sizes from 7mm to 61mm and also as customs up to 320mm, DT Series Collapsible Cores eliminate the need for complex unscrewing mechanisms as well as providing solutions for unmoldable internal undercut features such as o-ring grooves, slots, and snap fit details.

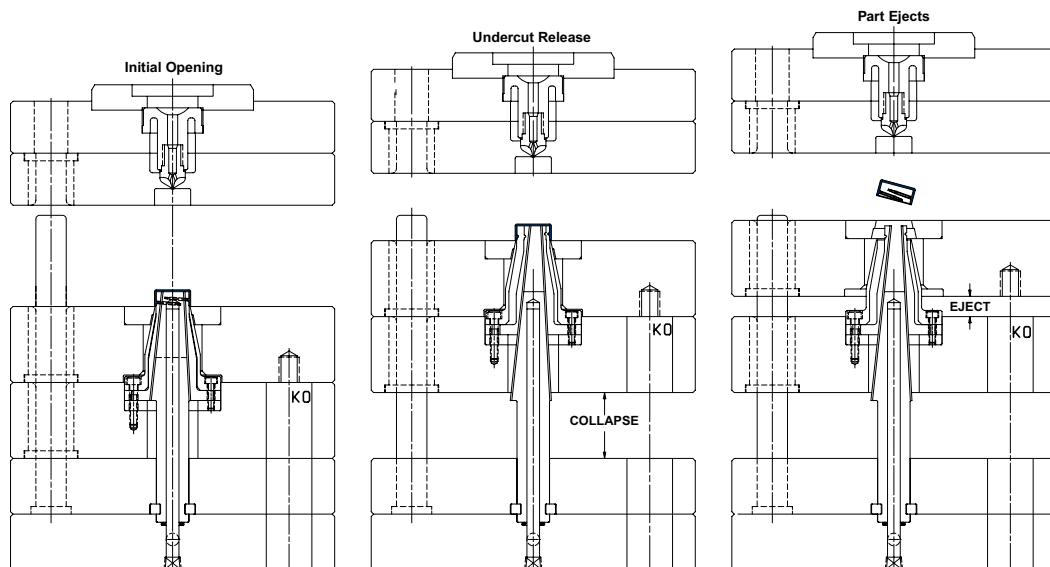
DT Cores allow for:

- Simplified, smaller molds
- Faster cycle times
- Improved part quality
- Reduced mold maintenance

Existing unscrewing molds can see performance improvements by retrofitting the movable side with DT Cores.



The DT Collapsible Core is a positive, mechanically actuated collapsible core that eliminates complex gear and rack approaches, resulting in a simpler mold and a faster cycle time.



DT Core molds are easily actuated with the machine knock outs.

COLLAPSIBLE CORES SUB-10 DT CORE SERIES

The Sub-10mm DT Cores make it possible to release very small threads and undercuts in molded caps, connectors and small medical applications.

- Allows molding of parts with 7-10mm ID.
- Optional Quick Lock Plates enable core removal from parting line.
- Simpler alternative to unscrewing molds.
- Reduces cycle time and maintenance requirements.



RT SERIES

The RT Series Collapsible Cores are available in sizes to fit most inside detail applications. Whether molding threads or complex details, these cores can simplify design and production.

Made from premium tool steels and heat treated using proprietary heat treating methods.

Standard diameters range from 13mm to 105mm.



CORE GRINDING FIXTURES AND ACCESSORIES

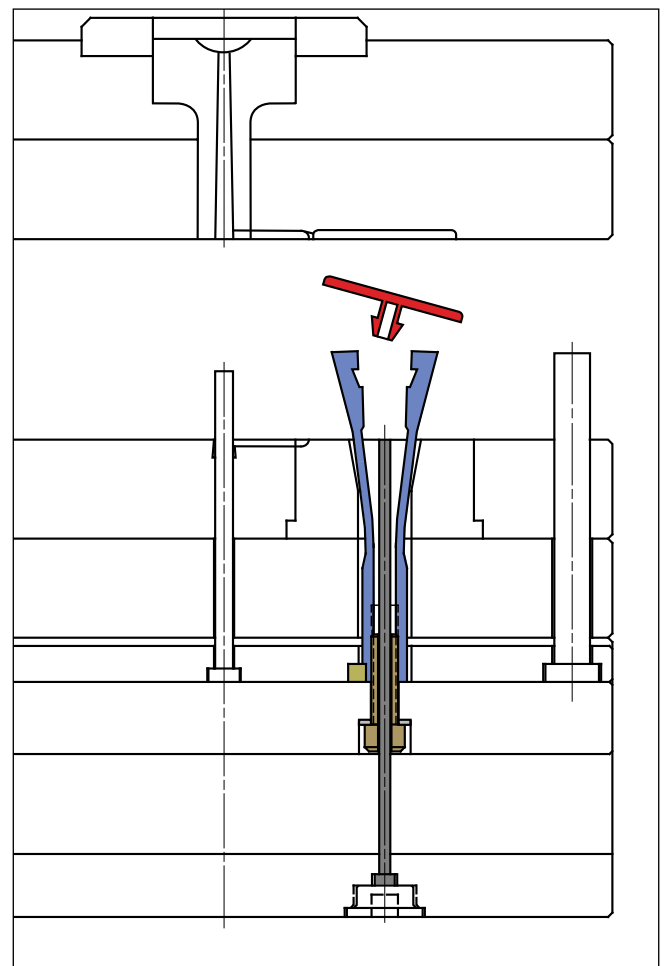
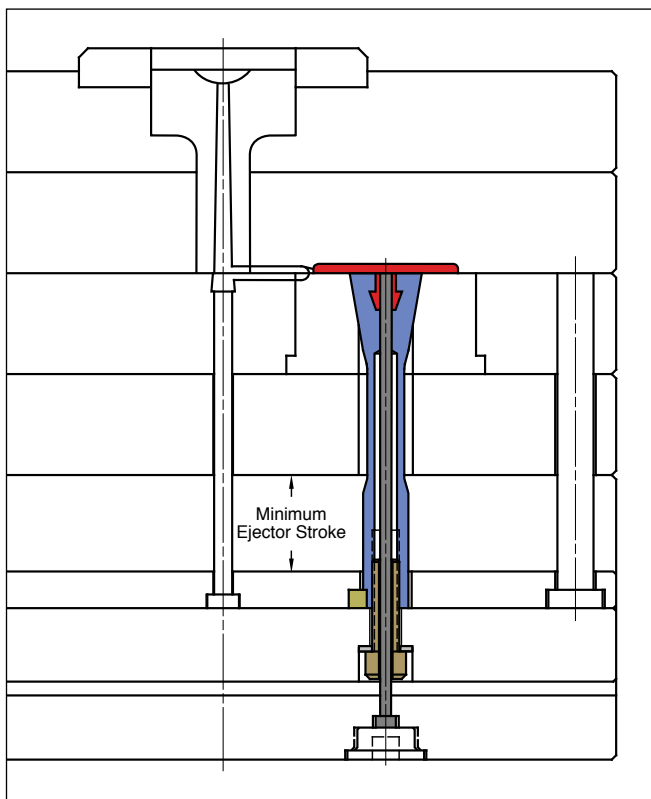
Grinding Rings for Collapsible Cores securely hold the core segments in place against the center pin when grinding or EDM'ing details.





EXPANDABLE CAVITIES EX-CAV® SYSTEM

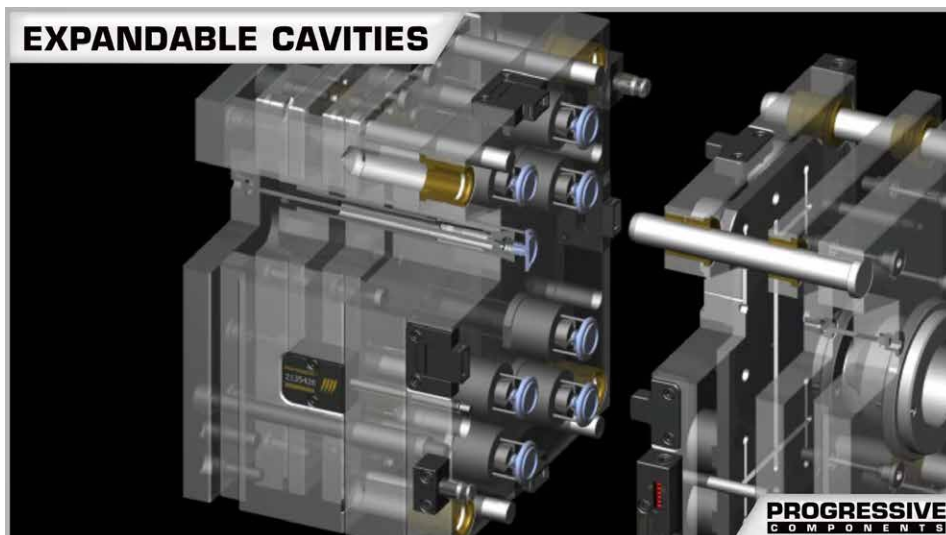
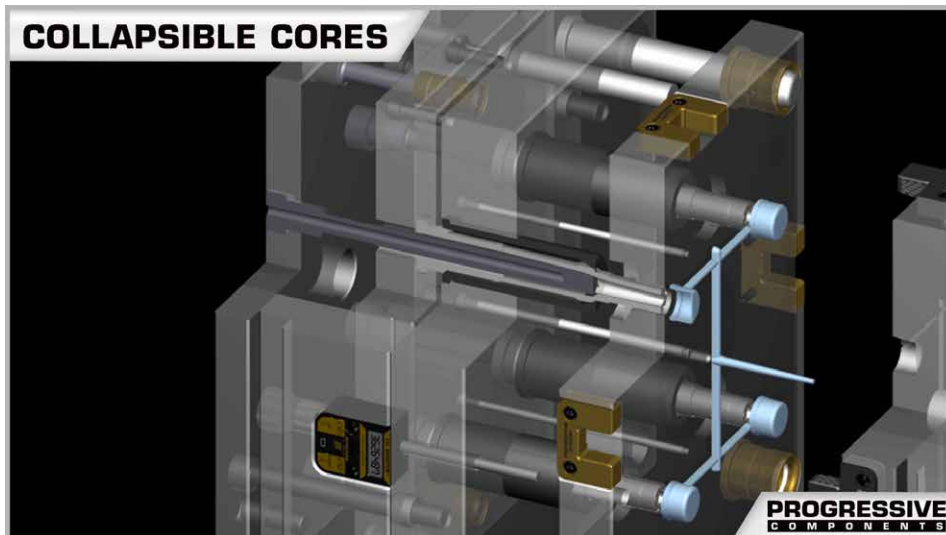
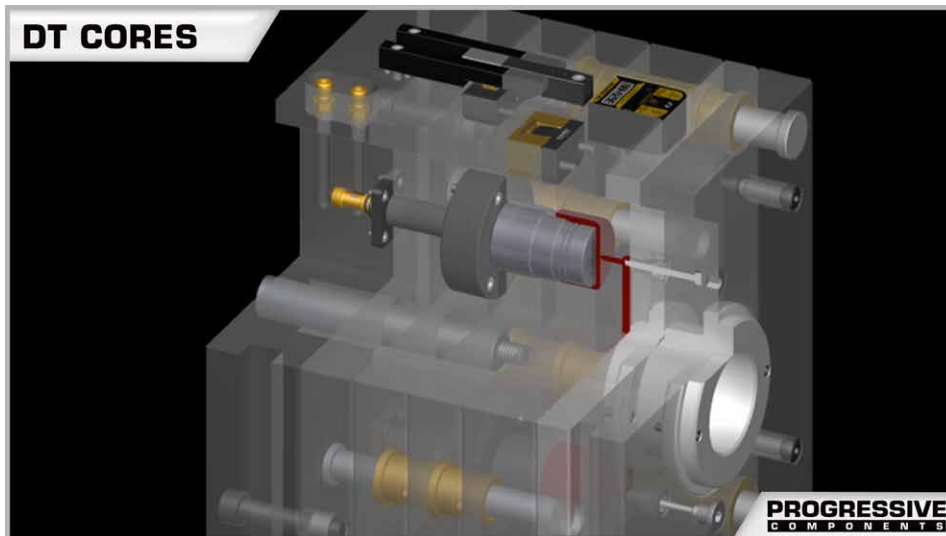
Expandable Cavities mold undercuts such as threads, dimples, and protrusion on the outside of molded parts. The patented Ex-Cav design eliminates the engineering, maintenance, and machining required for side action mechanisms which results in smaller molds or higher mold cavitation.



Contact Roehr Tool Solutions at information@RoehrTool.com for thread and undercut release solutions:

- Application Review/Quotations
- Engineering Services
- Prototyping & Product Development

ONLINE RESOURCES



When considering design options, numerous animations can be viewed at procomps.com and roehrtool.com.



PLATE SEQUENCE CONTROL

SECTION J



Plate Latch Locks: Cam Sequencing	Plate Latch Locks: Cam Block Seq.	Roller Pullers
Prefix: PLC, PLCM	Prefix: PLN	Prefix: RPL
Page: J-1	Page: J-5	Page: J-7



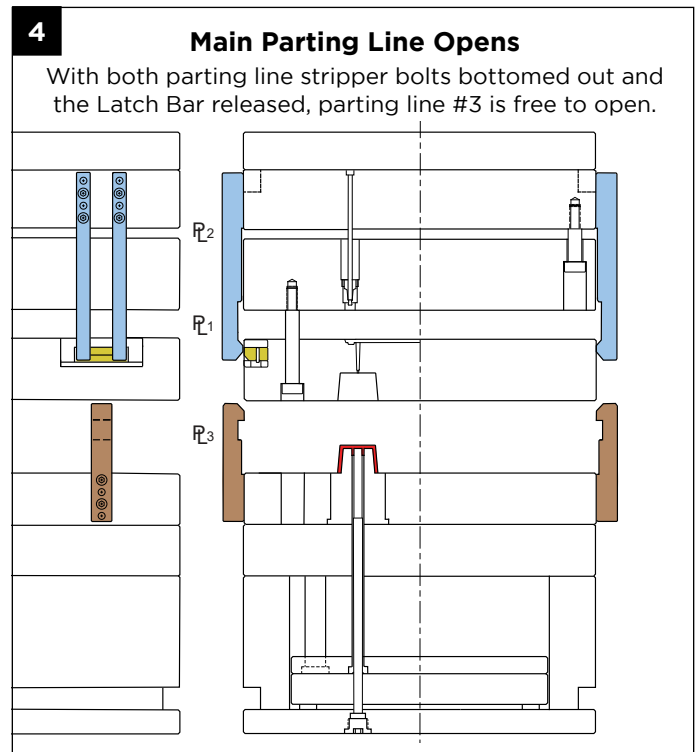
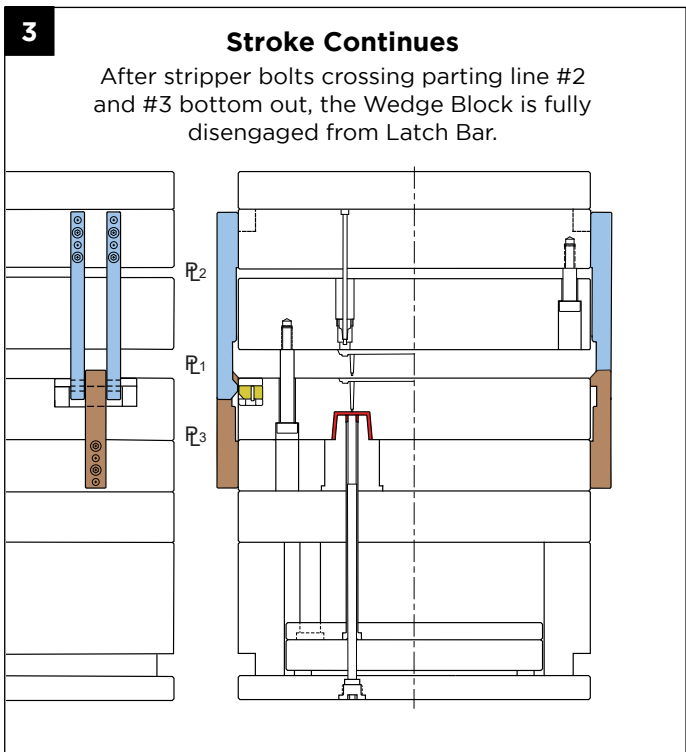
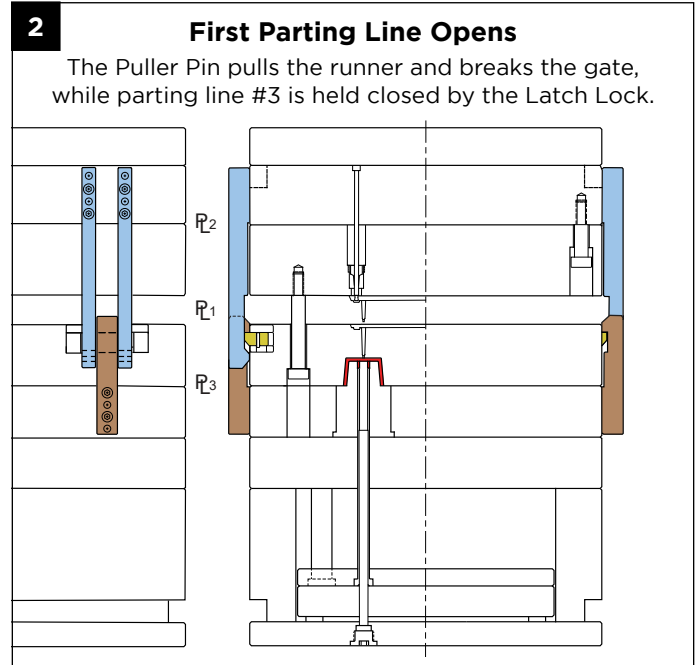
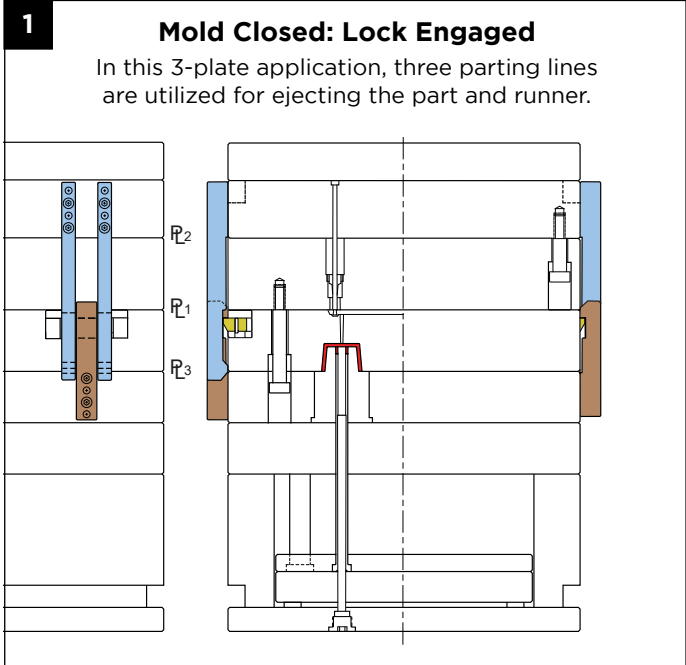
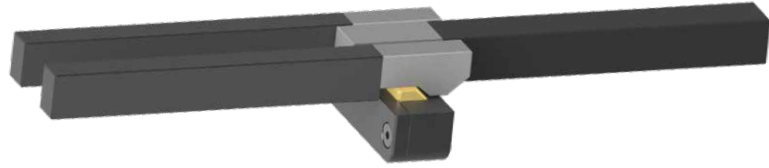
Plate Retainers	Two-Stage Ejectors	Ejector Accelerators
Prefix: PRT	Prefix: PLN	Prefix: EJA
Page: J-8	Page: J-10	Page: J-12



Plate Accelerators	Friction Pullers	StackKit System
Prefix: ACCPM	Prefix: FP	Prefix: SK
Page: J-13	Page: J-14	Page: J-15 - J-18



PLATE LATCH LOCKS CAM SEQUENCING



APPLICATION GUIDELINES

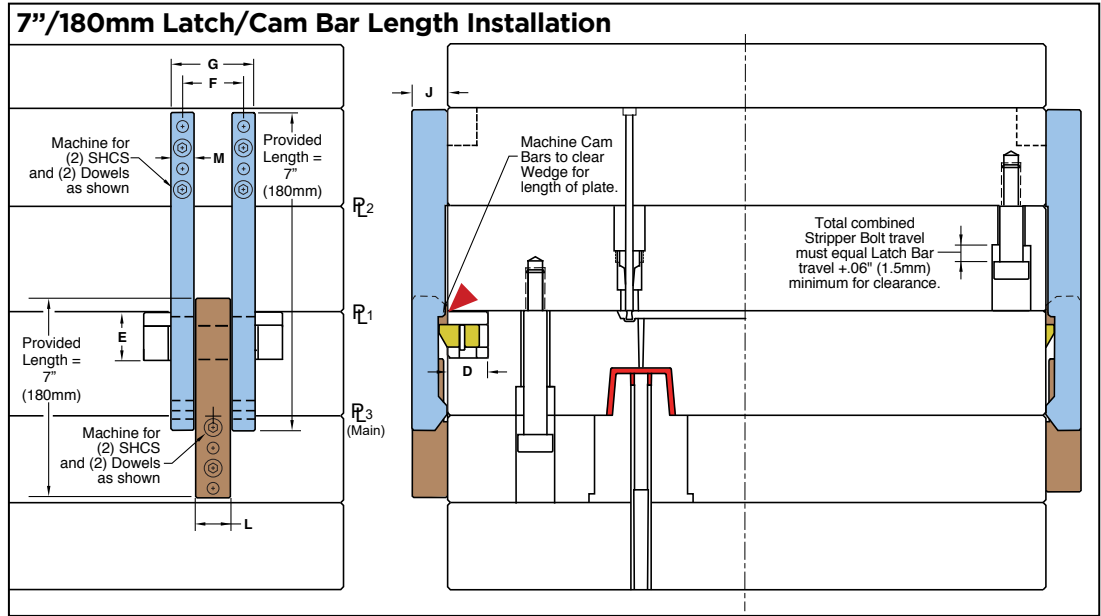
- The 7"/180mm assemblies are suggested for pulling 2,000 lbs (900 kg) each and the 12"/300mm assemblies are suggested for pulling 3,000 lbs (1360 kg) each. Weight ratings may vary based on gate size, friction conditions, and velocity.
- On molds that are 12" wide or more, Progressive recommends four assemblies, two sets per side on the opposite ends of the mold.
- Using four assemblies with the addition of four Stripper Plate Kits (-S version) to push plates is recommended for plates 12" or greater in width.

PLATE LATCH LOCKS

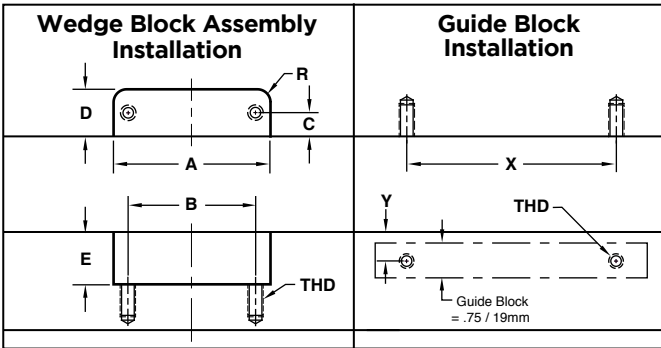
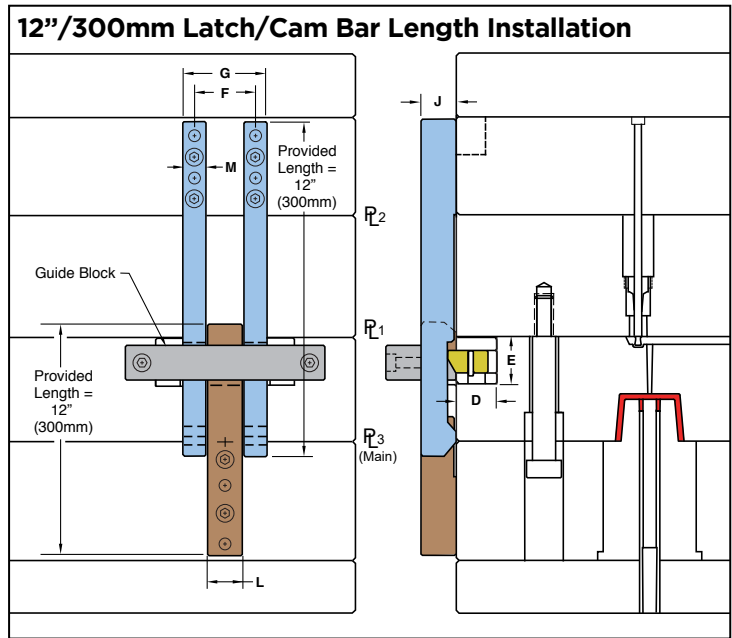
3-PLATE APPLICATION

Design & Installation:

1. Determine Latch travel.
2. Determine Stripper Bolt travel, .06 minimum clearance past Latch release.
3. Determine the Cam Bar length by utilizing the gauge pin and timing diagram on the opposite page.
4. Machine the Latch Bar so that with the mold closed there is .001" clearance between the Wedge Block and Latch Bar as shown in the timing diagram.
5. Machine (2) counterbores and (2) dowel holes for Latch and Cam Bar as shown. Two (2) dowels are recommended for proper alignment.
6. For all assemblies, the Wedge Block Assembly is installed according to the pocket dimensions below.
7. For the 12"/300mm assemblies, the Guide Block must be installed over the Latch and Cam Bars. The Guide Block will help to avoid deflection, causing latch timing issues, during production and can be purchased for optional use on the 7"/180mm assemblies. Screw size and locations are shown below, and it is suggested that location is on the center of the Wedge Block Assembly pocket, opposite the spring pressure.
8. Max operating temperature is 500°F (260°C).



CAD insertion point



Inch Standard

CATALOG NUMBER	A +.001 -.000	B ± .005	C ± .005	D +.001 -.000	E +.001 -.000	F ± .005	G REF	J	L	M	R POCKET	X ± .005	Y ± .005	THD
PLC75-7	3.001	2.44	.45	.900	1.000	1.31	1.80	.750	.750	.500	.250	3.625	.500	1/4-20 x .50 Deep
PLC75-12														

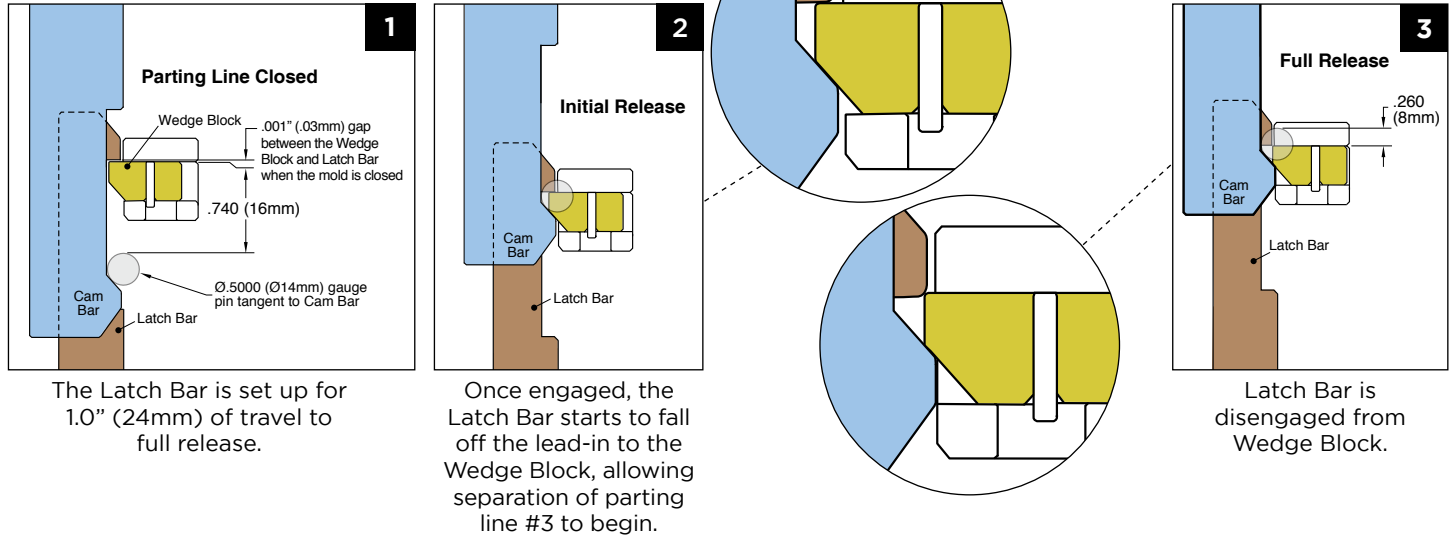
Metric Standard

CATALOG NUMBER	A +.03 -.00	B ± .1	C ± .1	D +.03 -.00	E +.03 -.00	F ± .1	G REF	J	L	M	R POCKET	X ± .1	Y ± .1	THD
PLCM20-180	80.02	64	12	24	27	35	49	20	20	14	7	92	13.5	M6-1.0 x 10mm Deep
PLCM20-300														

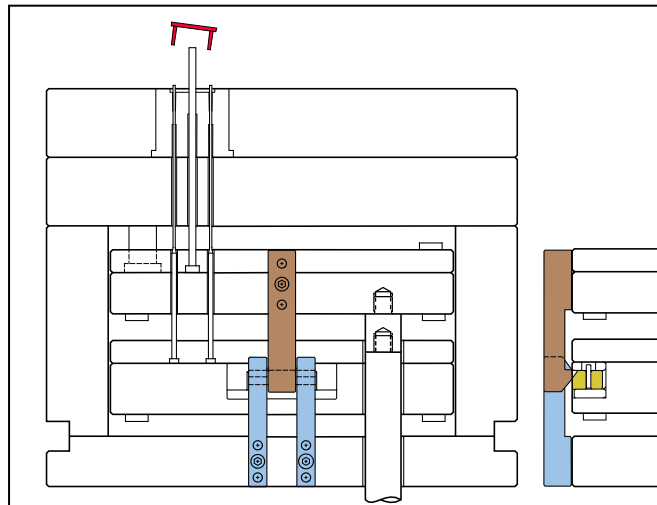


PLATE LATCH LOCKS TIMING

For Cam Bar Release Point

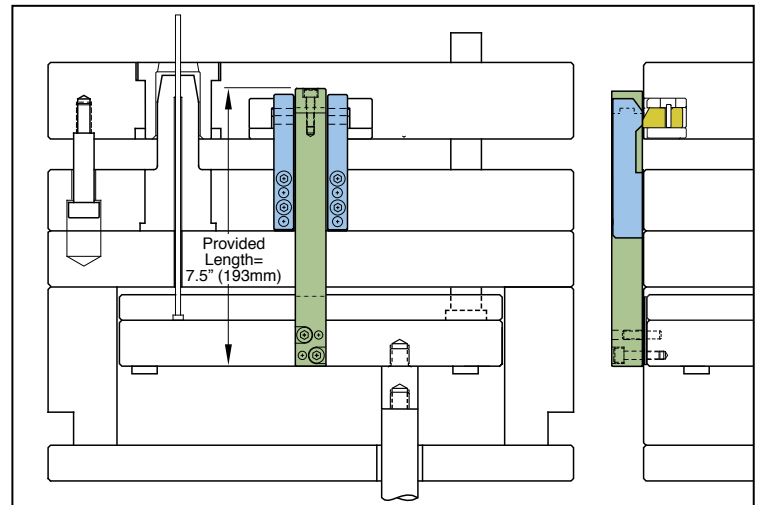


APPLICATIONS



Dual Ejection

Plate Latch Locks keep both ejector sets together until the release point. The Wedge Block Assembly would be installed in the bottom ejector plate, following the installation of all components.



Stripper Plate

The Drivers push the stripper plate forward until the parts are stripped from the core. The lock then releases, allowing the ejector pins to push the parts from the stripper plate.

APPLICATION GUIDELINES

- Stripper plate applications can be utilized as shown above with the optional Stripper Plate Kit as sold on page J-4. The Latch Bar will be discarded and replaced with the Driver, Cap, and Spacer offered in the kit.
- All pocket and component machining is similar to the 3-plate application shown on page J-2 except for calculation of the "T" dimension for timing the release point according to the graphic at right.
- Use the Spacer as a template for machining the bolts/dowels on the Driver/Cap assembly.
- Attach the Spacer to the Driver, which will provide .03"(.75mm) gap between the Driver and the mold to avoid interference.

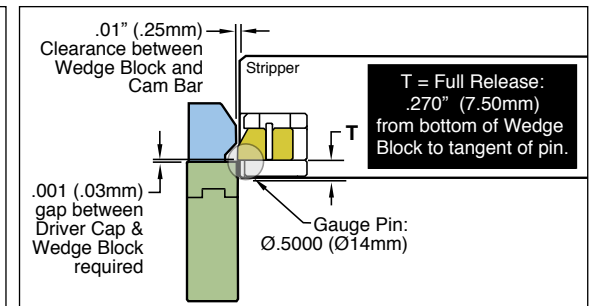


PLATE LATCH LOCKS CAM SEQUENCING

ASSEMBLY CATALOG NUMBER	LATCH/CAM BAR LENGTHS
PLC75-7	7.0
PLC75-12	12.0
PLCM20-180	180mm
PLCM20-300	300mm

Assemblies include:

- All machined components listed below.
- Items within the Wedge Block Assembly:
 - Compression Springs (2)
 - 1/4-20 LHCS or M6-1.0 LHCS (2 per assembly)
 - 1/8 or 3mm Diameter Dowel Pin (1 per assembly)
- Screws within the Guide Block (12"/300mm assemblies)
 - 1/4-20 LHCS or M6-1.0 LHCS (2 per assembly)

PART NAME	MATERIAL/TREATMENT
Latch Bar	4340, 35-40 HRC, Nitride/Black Oxide
Cam Bars (2)	4340, 35-40 HRC, Nitride/Black Oxide
Wedge Block Assembly	Wedge Block: A-2, 58-60 HRC Titanium Nitride
	Guide & Guide Plate: H-13, 52-54 HRC Nitride/Black Oxide
Guide Block	H-13, 52-54 HRC, Nitride/Black Oxide

The Guide Block may also be utilized on the 7"/180mm assemblies. To order the assembly which includes screws, specify PLC75-GBA for inch standard and PLCM20-GBA for metric.

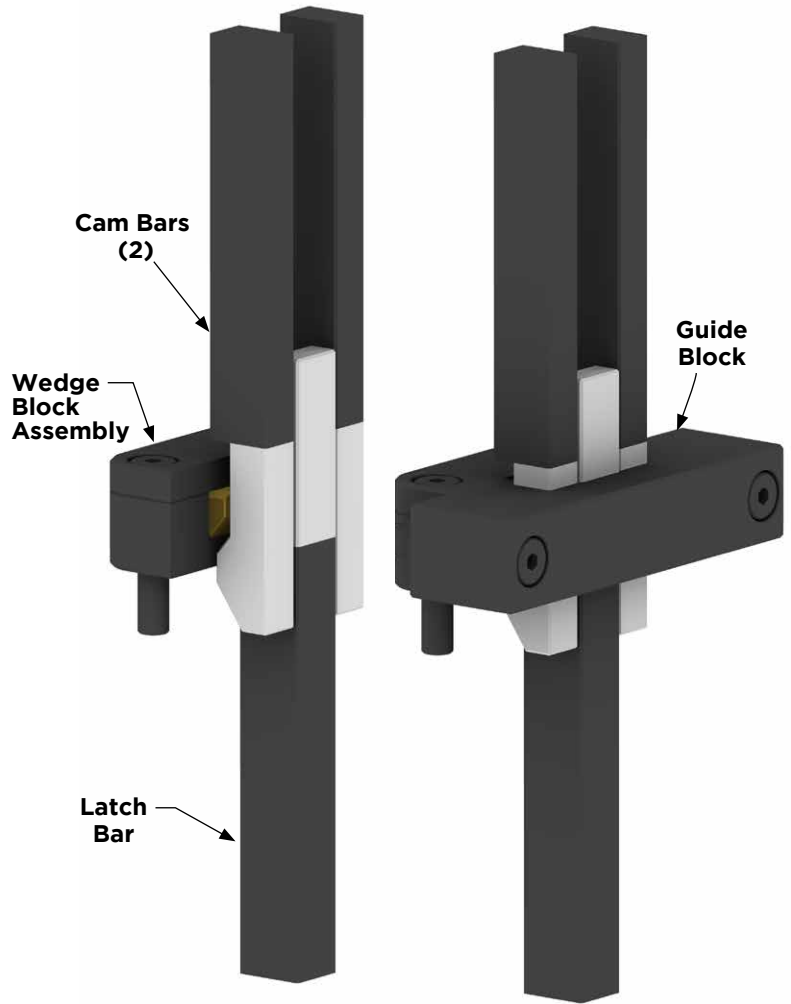


PLATE LATCH LOCKS STRIPPER PLATE KIT

For stripper plate applications, purchase the appropriate metric or inch assembly from the top of the page and the matching kit below. The mold maker will discard the Latch Bar, replacing it with the Cap/Driver/Spacer shown at right.

CATALOG NUMBER	STANDARD
PLC75-S	Inch
PLCM20-S	Metric

Assembly includes:

- All machined components listed below.
- (1) #10-32 x .75 or M5-.8 x 30mm SHCS

PART NAME	MATERIAL/TREATMENT
Cap	4340, 35-40 HRC, Nitride
Driver	4140, 28-35 HRC, Black Oxide
Spacer	303 Stainless Steel, 35-40 HRC

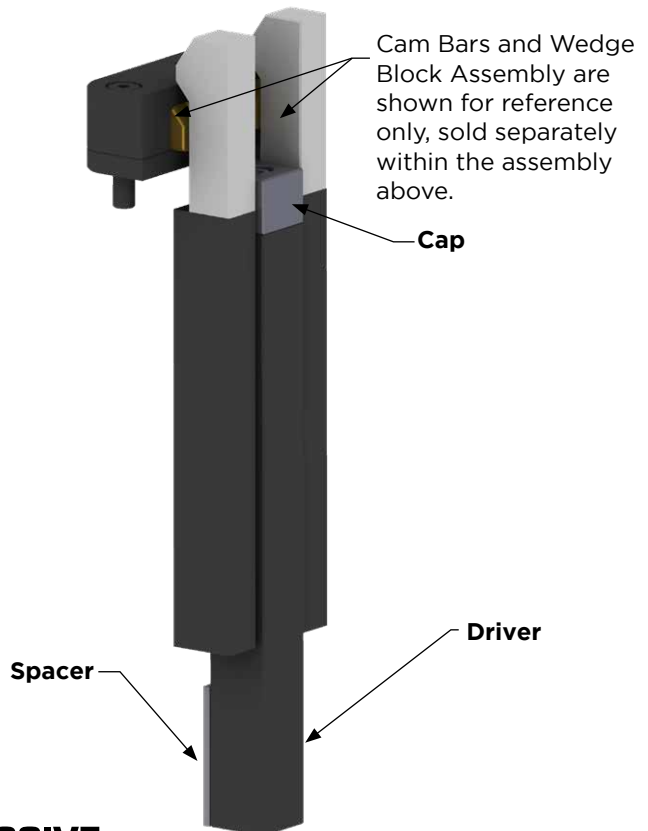
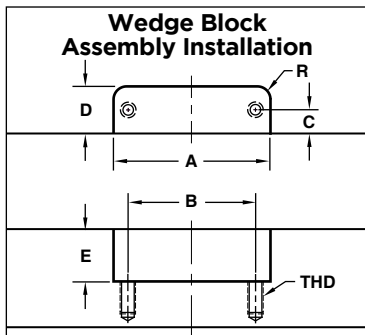
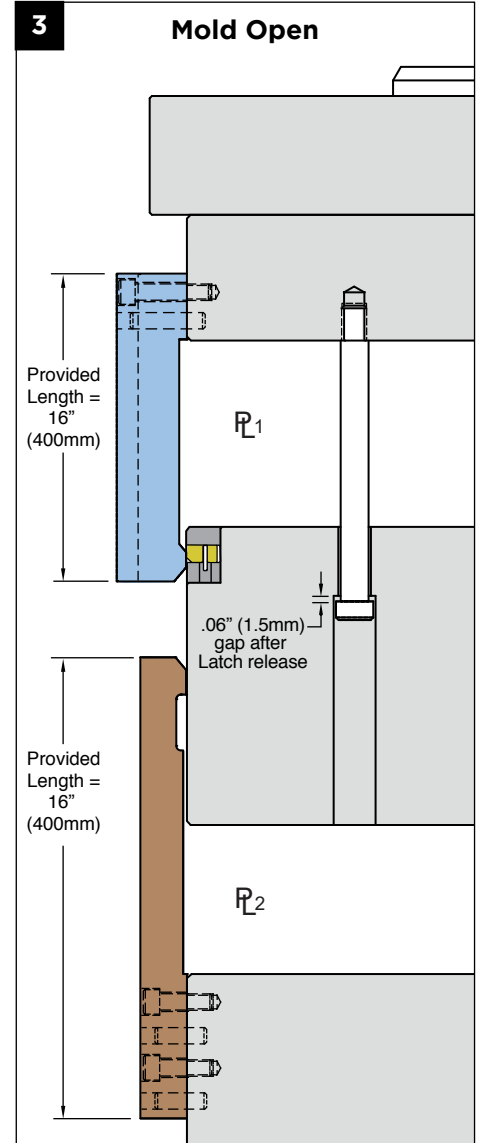
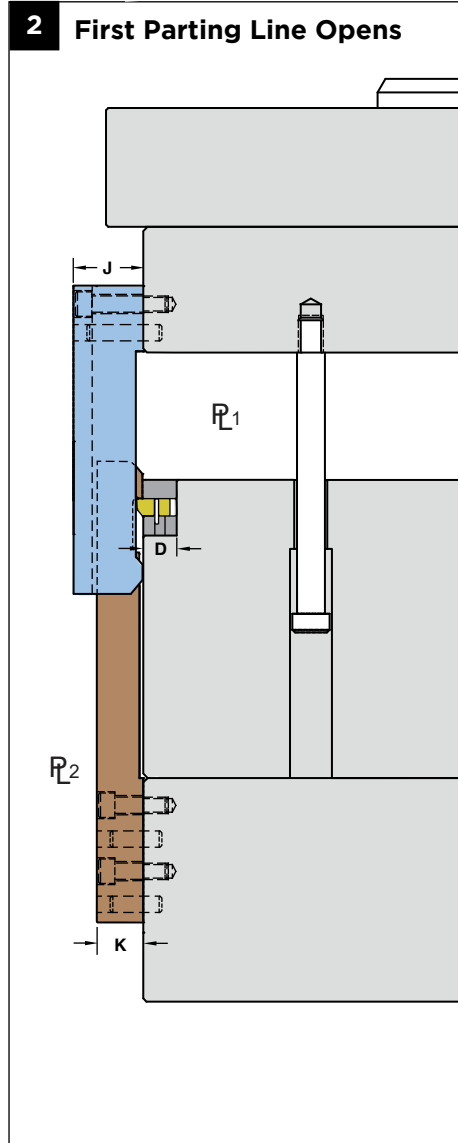
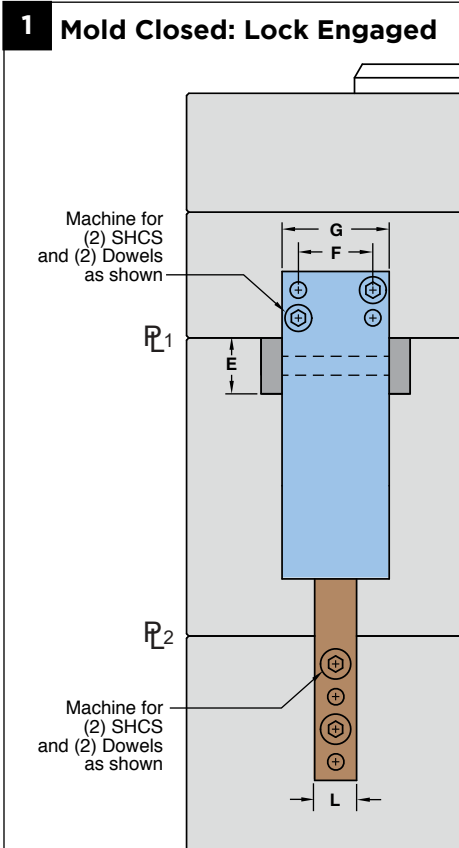




PLATE LATCH LOCKS

CAM BLOCK SEQUENCING



Refer to page J-6 for design and installation guidelines.

Inch Standard

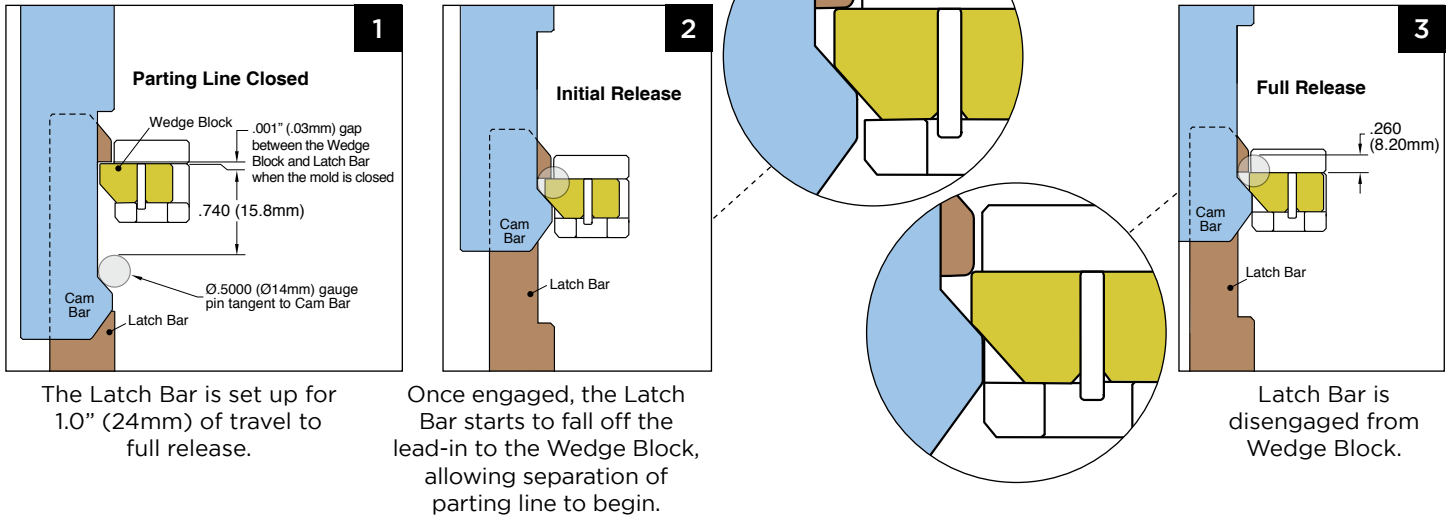
CATALOG NUMBER	A +.001 -.000	B ± .005	C ± .005	D +.001 -.000	E +.001 -.000	F ± .005	G REF	J	K	L	R POCKET	THD
PLC125-16	4.001	3.25	.45	.900	1.500	2.00	2.875	1.875	1.250	1.125	.250	5/16-18

Metric Standard

CATALOG NUMBER	A +.03 -.00	B ± .1	C ± .1	D +.03 -.00	E +.03 -.00	F ± .1	G REF	J	K	L	R POCKET	THD
PLCM32-400	100	82	12	24	36	50	75	47	32	28	7	M8-1.25

PLATE LATCH LOCKS TIMING

For Cam Bar Release Point

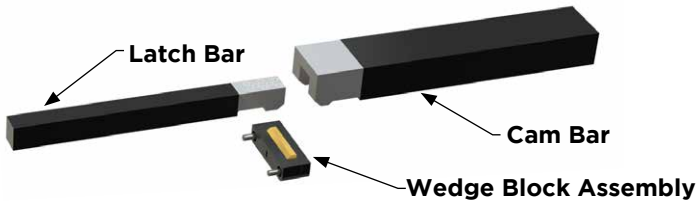


APPLICATION GUIDELINES

- Recommended pulling limit is 6,000 lbs (2,700kg) each.
- Determine the Cam Bar length by utilizing the gauge pin and timing diagram.
- Machine the Latch Bar so that with the mold closed there is .001" (.03mm) clearance between the Wedge Block and Latch Bar as shown in the timing diagram.
- Machine (2) counterbores and (2) dowels for Latch and Cam Bar as shown on page J-5. Two (2) dowels are recommended for proper alignment.
- Max operating temperature is 500°F (260°C)

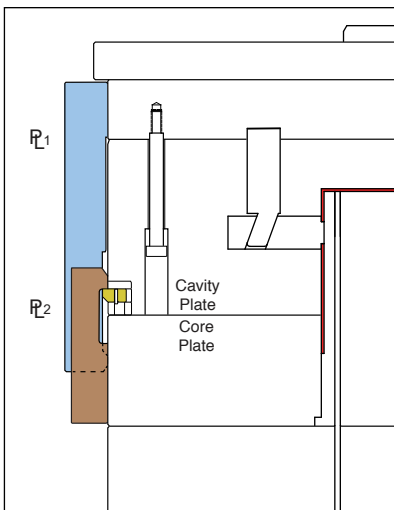
Assemblies include:

- All machined components listed below.
- Items within the Wedge Block Assembly:
 - Compression Springs (2)
 - 5/16-18 x 1.75" SHCS or M8-1.25 x 40mm SHCS (2)
 - 1/8 Diameter Dowel Pin (1)

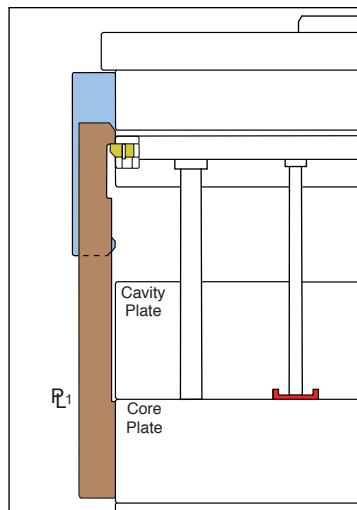


PART NAME	MATERIAL/TREATMENT
Latch Bar	4340, 35-40 HRC, Nitride/Black Oxide
Cam Bar	4340, 35-40 HRC, Nitride/Black Oxide
Wedge Block Assembly	Wedge Block: A-2, 58-60 HRC Titanium Nitride
	Guide & Guide Plate: H-13, 52-54 HRC Nitride/Black Oxide

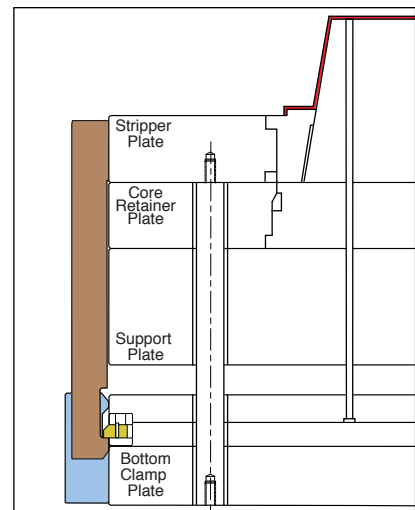
Floating A-Plate



A-Side Ejection

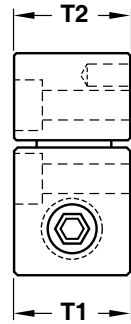
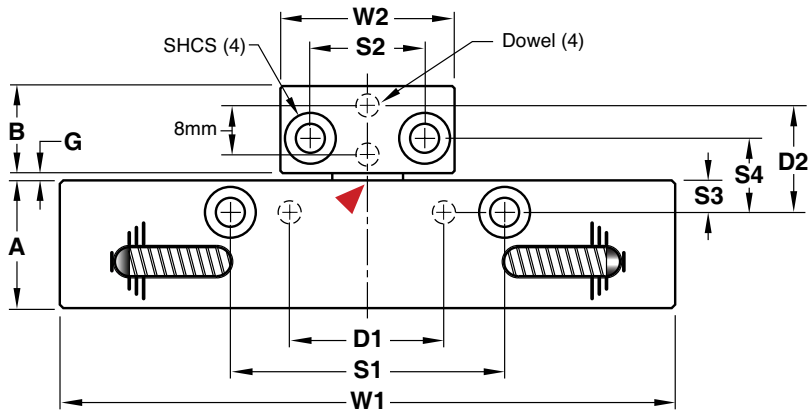


Stripper Plate Ejection

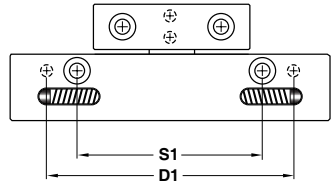




ROLLER PULLERS™



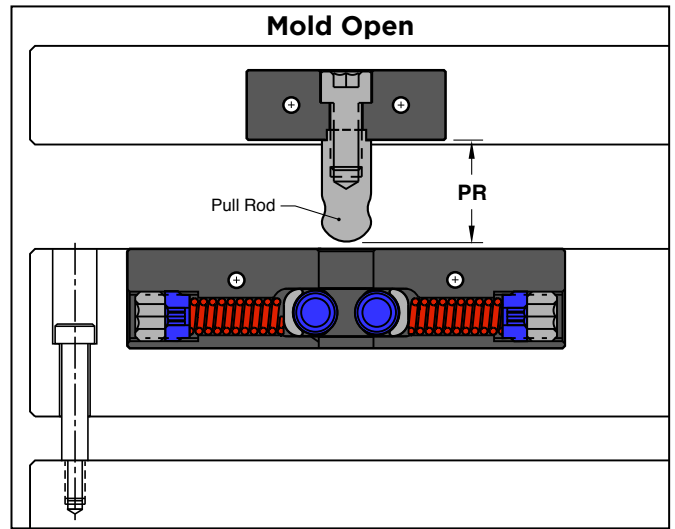
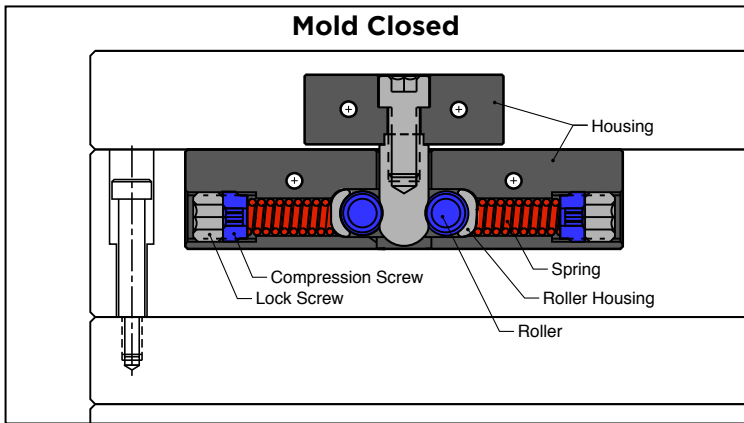
Screw and dowel orientation for RPL-140 and RPL-140-40



▶ CAD insertion point

Housing: **M** 4140 **H** 27-32 HRC **S** Black Oxide
 Roller: **M** M-2 **H** 62-64 HRC, Nitrided
 Pull Rod: **M** M-2 **H** 62-64 HRC, Nitrided

CATALOG NUMBER	W1	T1	W2	T2	A	B	G	S1	S2	S3	S4	D1	D2	DOWEL DIA.	SHCS	PR
RPL-135	135	25	38	25	28	19	1	60.0	25.0	7.0	15.6	30.0	22.1	5	M6-1.0 x 25	26
RPL-135-40	135	25	38	25	28	19	40	60.0	25.0	7.0	54.6	30.0	61.1	5	M6-1.0 x 25	65
RPL-140	140	32	64	25	32	22	2	70.0	35.0	10.0	23.1	100.0	28.1	6	M10-1.5 x 35	30
RPL-140-40	140	32	64	25	32	22	38	70.0	35.0	10.0	59.3	100.0	64.3	6	M10-1.5 x 35	66



APPLICATION GUIDELINES

- Mounting pattern matches industry standards.
- Compression screw provides adjustable pull force.
- Roller design allows for smooth action.
- Mounting screws and dowels included.
- Roller Pullers are available with special length rods to suit applications where a different distance between the housings is required. For pricing and delivery, contact tech@procomps.com with the catalog number above along with the required gap or "G" dimension.

Pull Force

Tighten lock screws equally to achieve forces below.

CATALOG NUMBER			
RPL-135	45 Kg (100 lbs)	75 Kg (160 lbs)	100 Kg (220 lbs)
RPL-135-40	45 Kg (100 lbs)	75 Kg (160 lbs)	100 Kg (220 lbs)
RPL-140	45 Kg (100 lbs)	100 Kg (220 lbs)	150 Kg (330 lbs)
RPL-140-40	45 Kg (100 lbs)	100 Kg (220 lbs)	150 Kg (330 lbs)

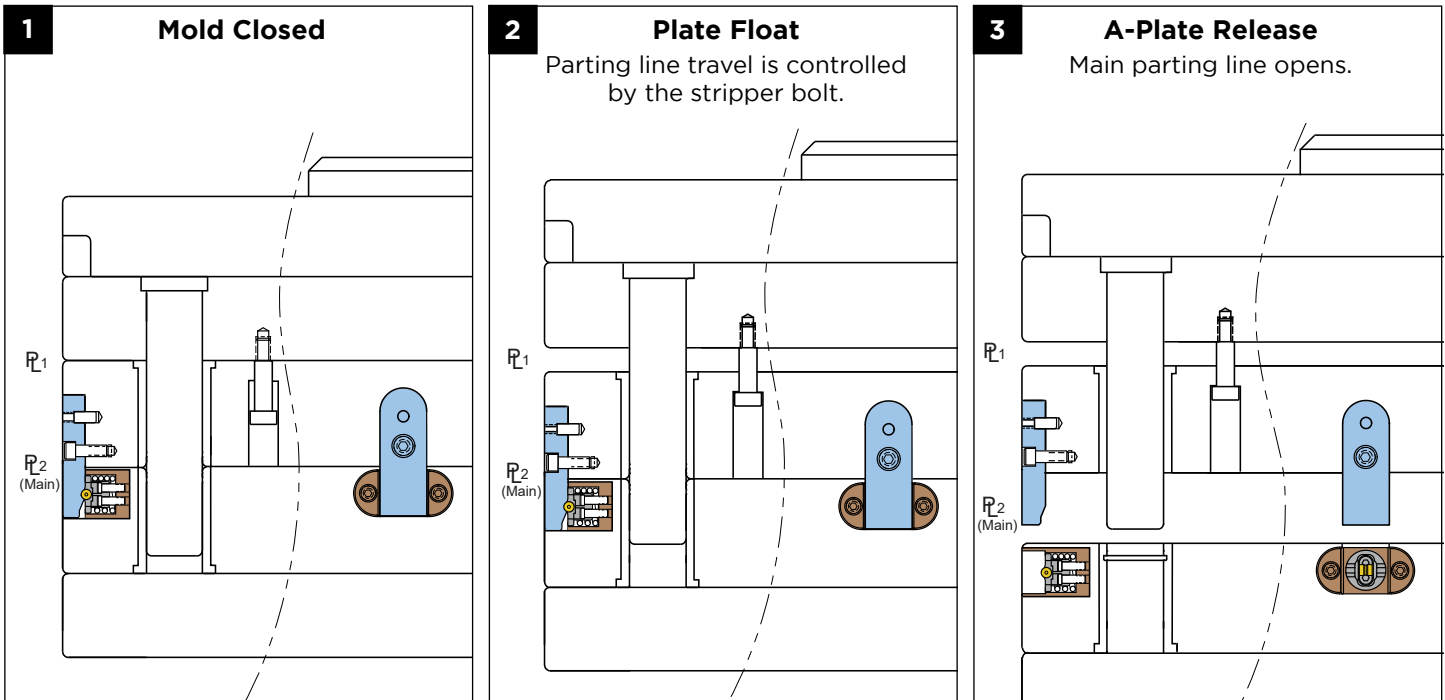
PLATE RETAINERS



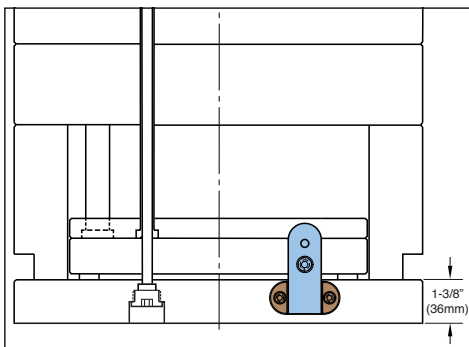
The Plate Retainer is designed to hold parting lines or retain plates for sequence functions. The Plate Retainer can also be used in conjunction with other latch components to ensure desired sequencing.

- Incorporates the SRT Slide Retainer for greaseless retention.

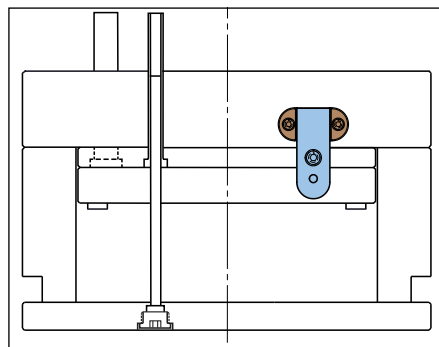
Floating A-Plate Application



Ejector Plate Applications

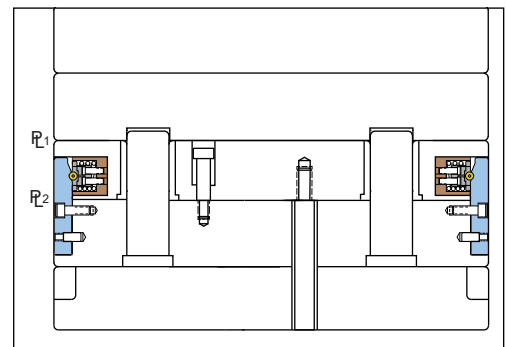


With a 1-3/8" (36mm) bottom clamp plate, the Plate Retainer can be used to retain ejector plates in the molding position.



The Plate Retainer can also retain the pin plates in position at the end of a ejector stroke.

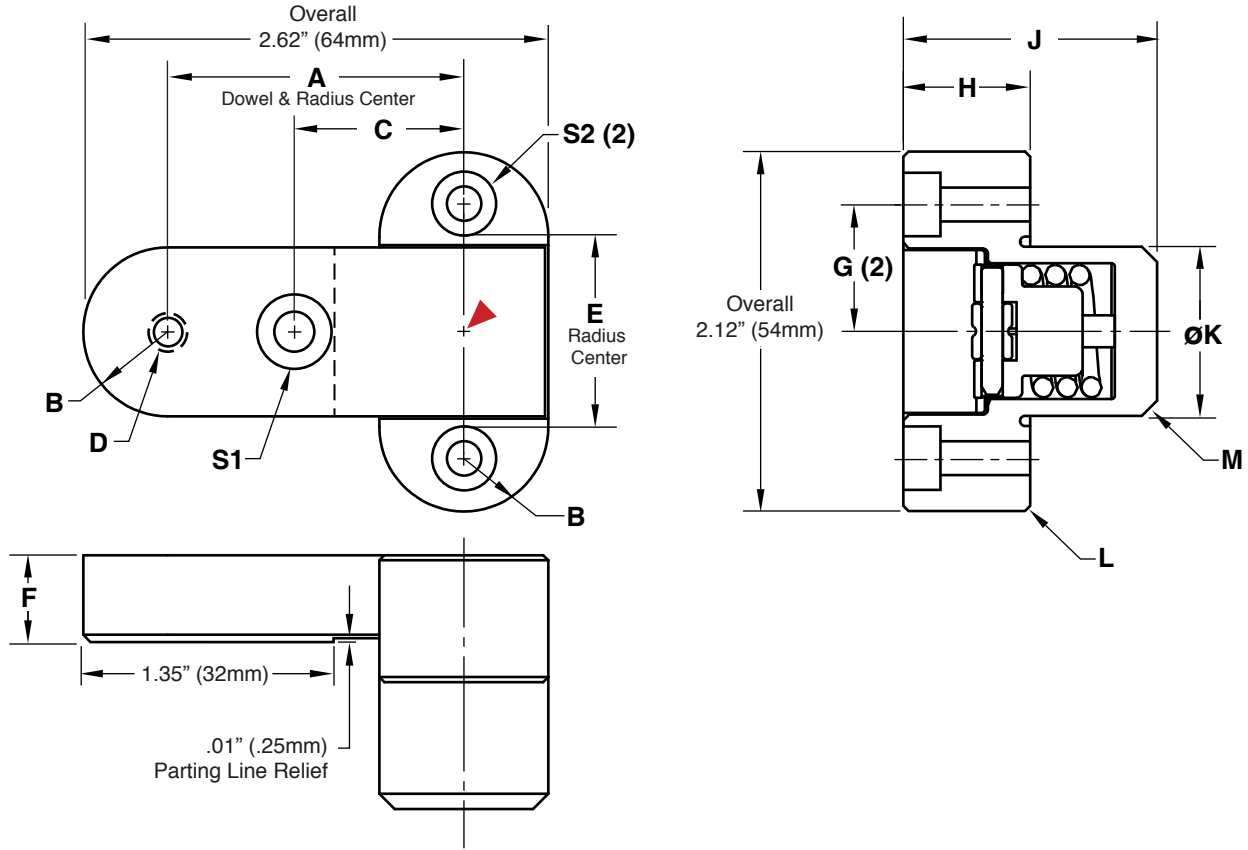
Stripper Plate Application



The Plate Retainer can be used to keep stripper plates in molding position during mold open.



PLATE RETAINERS



Inch Standard

Housing: **M** D-2 **H** 50-54 HRC **S** Black Oxide

Retainer Bar: **M** 1045 **H** 50-54 HRC **S** Black Oxide

▶ CAD insertion point

CATALOG NUMBER	A	B RADIUS	C ± .01	D DOWEL	E	F +.000 - .005	G ± .01	H +.000 - .005	J +.000 - .005	K +.000 - .002	L CHAMFER	M CHAMFER	S1 SHCS	S2 SHCS
PRT80-260	1.625	.500	1.125	1/4 x 1/2	1.125	.500	.750	.750	1.500	1.000	.03	.09	1/4-20 x 5/8	#10-32 x 7/8

Metric Standard

CATALOG NUMBER	A	B RADIUS	C ± .25	D DOWEL	E	F +.00 - .13	G ± .01	H +.00 - .13	J +.00 - .13	K +.00 - .13	L CHAMFER	M CHAMFER	S1 SHCS	S2 SHCS
PRTM36-64	39	12.5	28	6 x 12	29	12	20	18	38	25	.8	2.5	M6 x 14	M6 x 20

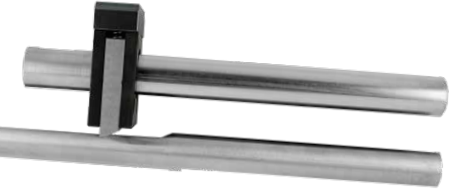
Screws, dowels, and Slide Retainer are included.

APPLICATION GUIDELINES

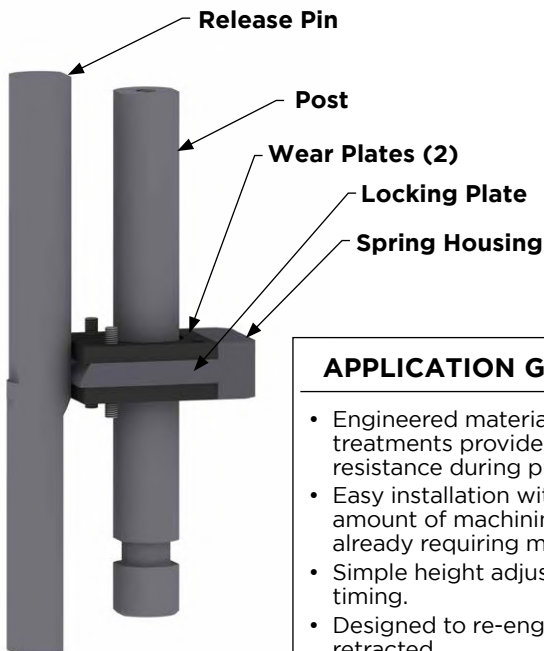
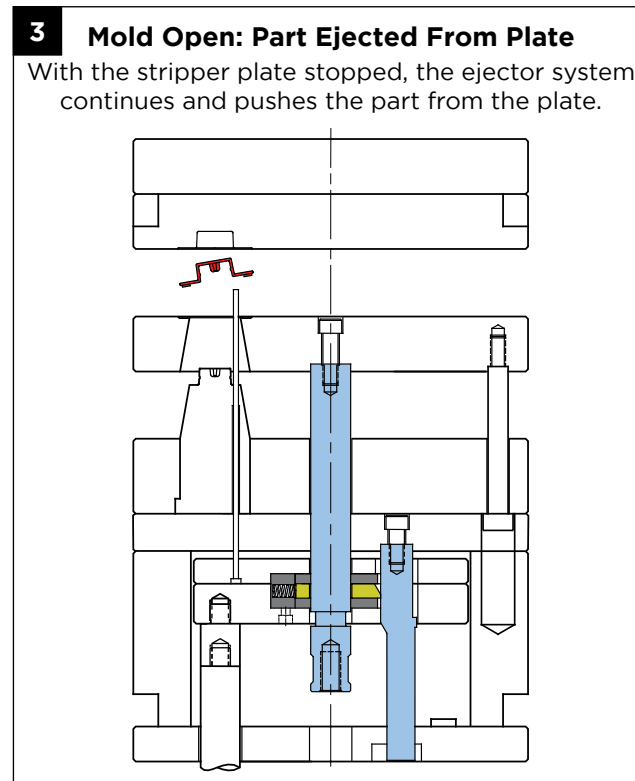
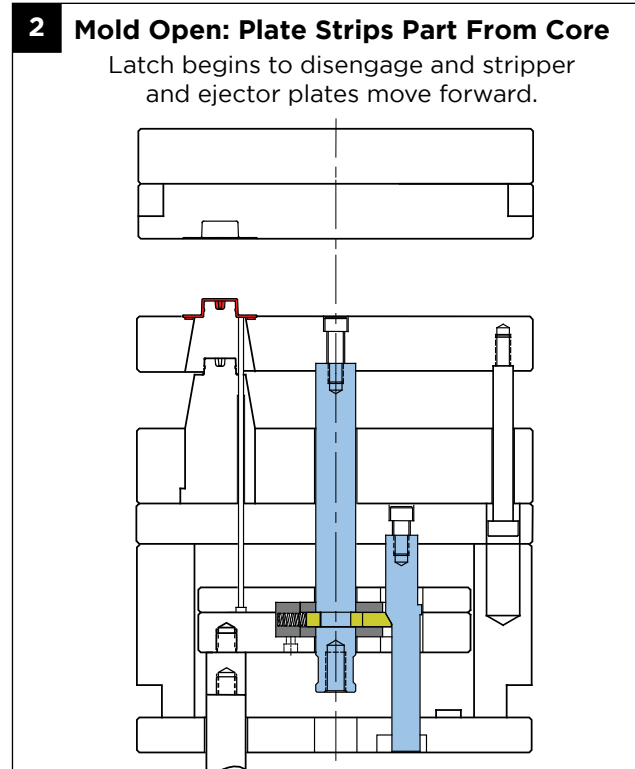
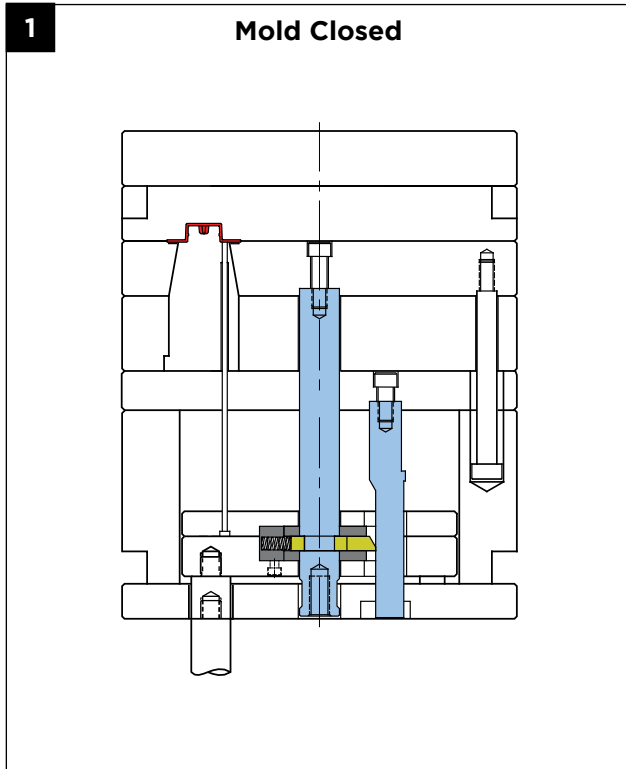
- The holding force rating for the PRT80-260 is 80 lbs and the PRTM36-64 is 36 kgs.
- It is recommended that four (4) Plate Retainer assemblies are installed, two (2) on each side of the tool, when using to pull plate weights up to 300lbs (120kg) or with approximate plate sizes of 20 x 28 x 1-7/8" (396 x 796 x 46mm) and 18 x 24 x 2-3/8" (346 x 696 x 66mm).
- Leader Pins must be engaged before the Retainer Bar enters the Plate Retainer housing assembly.
- Max operating temperature is 425°F (220°C).

TWO STAGE EJECTORS

INTERNAL PLATE LATCH



Two Stage Ejectors provide a positive, mechanical method for locking and actuating plates in molds requiring multiple ejection actions. Optionally, using the press knock-out locations, the internal ejection system can be used to actuate the ejectors after the stripper plates.

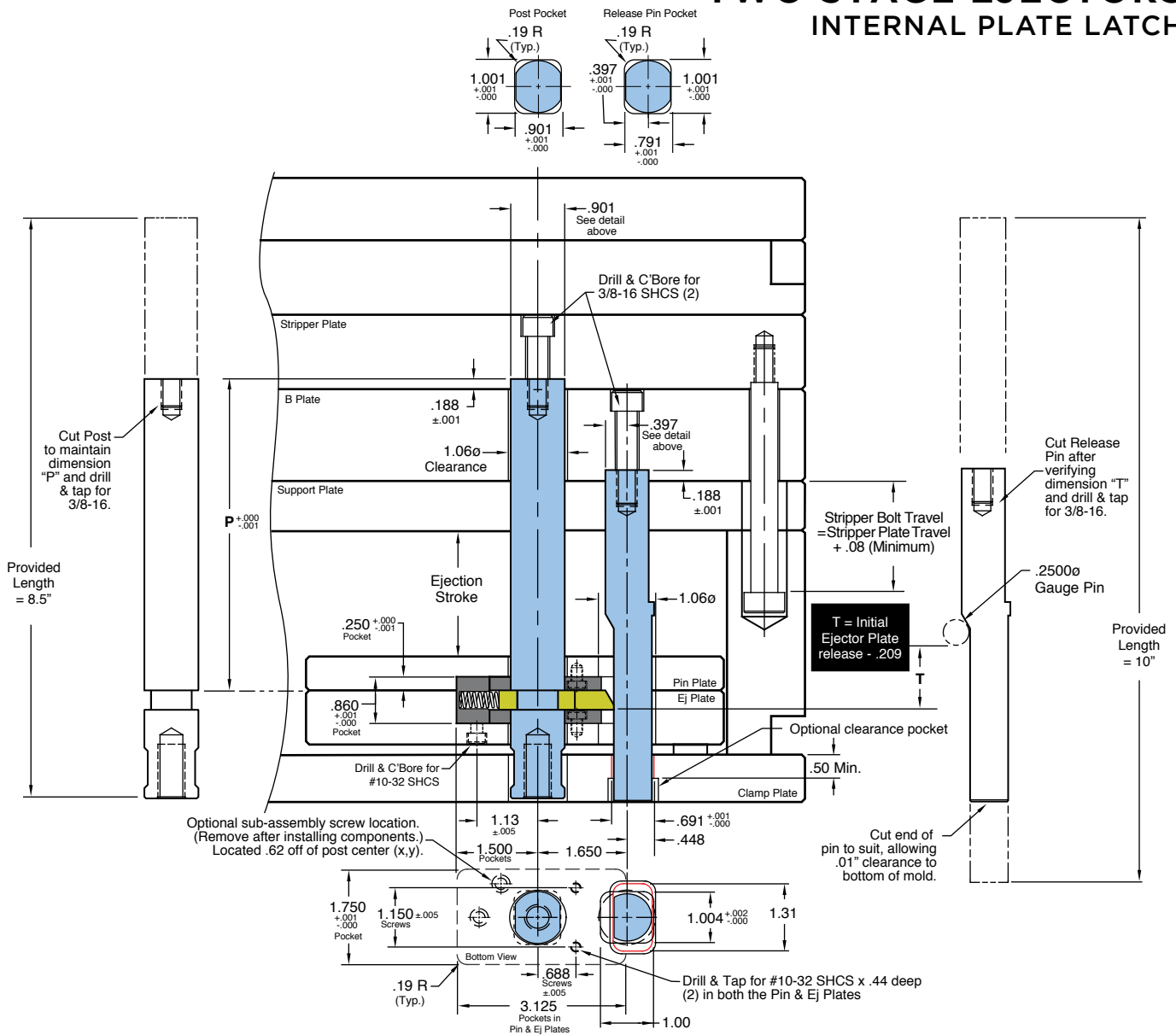


- APPLICATION GUIDELINES**
- Engineered materials and treatments provide wear resistance during production.
 - Easy installation with only a small amount of machining on plates already requiring modification.
 - Simple height adjustment and timing.
 - Designed to re-engage when fully retracted.
 - For activating large mold plates, multiple Ejectors can be installed.



TWO STAGE EJECTORS

INTERNAL PLATE LATCH



CATALOG NUMBER	DESCRIPTION
PLN100	Two Stage Assembly

Assembly includes:

- All five machined components listed at right.
- Compression Springs (2)
- #10-32 LHCS (4)

PART NAME	MATERIAL/TREATMENT
Locking Plate	A-2, 58-60 HRC
Wear Plate (2)	H-13 50-54 HRC, Nitrided, Black Oxide
Spring Housing	4140, 28-32 HRC
Release Pin	4340, 30-35 HRC, Nitrided
Post	4340, 30-35 HRC, Nitrided

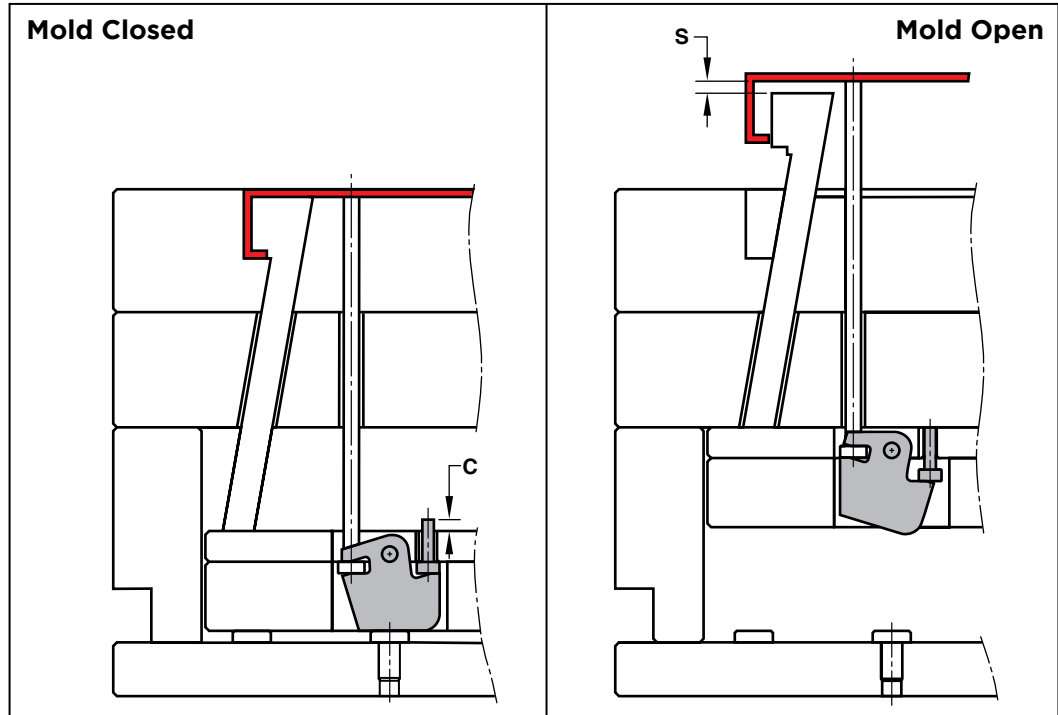
APPLICATION GUIDELINES

- It is recommended that ejector rods or PKO extensions are tied into the pin plates and guided ejection is utilized.
- For small molds (12 x 20 max), one or two assemblies may be used. For molds larger than 12 x 20, four assemblies should be installed.
- On all designs, consider fastener and assembly access points and install the Latches equal distances from center to ensure proper balance of the mold.
- Determine the Post length by verifying the distance in dimension "P" according to the information above. Cut, drill, and tap the Post to suit.
- By using a .250 diameter gauge pin tangent to the flat and the angle on the Release Pin, determine the release point "T" as shown above.
- Calculate the overall length of the Release Pin and then cut, drill, and tap.

INSTALLATION GUIDELINES

- Machine all pockets per the drawing above.
- Bolt the Release Pin and Post to the B-side plates.
- Ejector plates are then assembled with the Wear Plate, Locking Plate, and Spring Housing.
- Locking plate is retracted to allow for the temporary keeper screw installed. This allows the Locking Plate to pass over the Post and also have clearance to Release Pin.
- Ejector plates are to be installed onto guided ejector pins and placed in the proper location, lining up Locking Plate with relief in the Post.
- Finally, remove the temporary keeper screw, allowing the Locking Plate to snap into the relief within the Post.

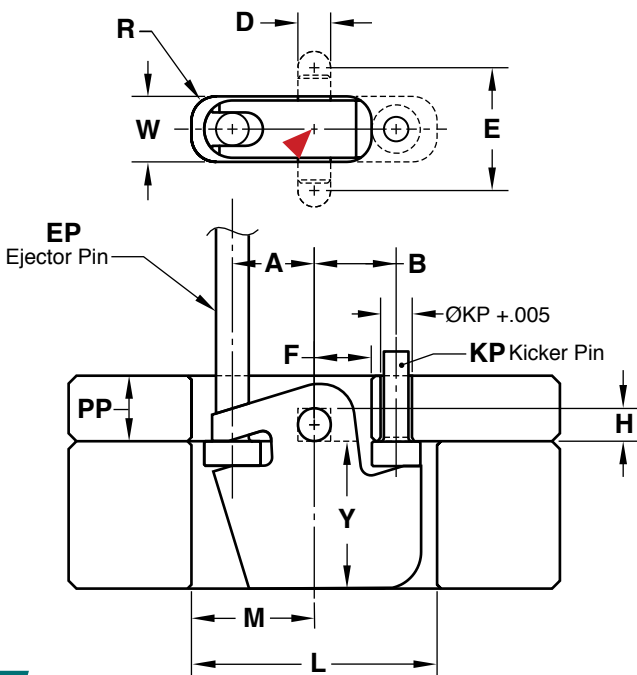
EJECTOR ACCELERATORS



Accelerator: **M** D-2 **H** 48-52 HRC **S** Black Oxide
 Kicker Pin: **M** H-13 **H** 48-50 HRC, Surface 66-70 HRC

▶ CAD insertion point

CATALOG NUMBER	EP DIA.	S MAX	KP DIA.	A	B	C MAX	D ^{+0.001} _{-.000}	E ± .01	W ± .01	R	F	M	L	H ^{+0.002} _{-.000}	PP MIN	Y
EJA125	1/8	.110	1/8	.375	.438	.125	.188	.687	.31	.16	.28	.53	1.13	.188	.500	1.000
EJA250	1/4	.196	3/16	.625	.625	.186	.250	1.00	.50	.19	.44	.94	1.88	.250	.500	1.000
EJA375	3/8	.200	1/4	.750	.750	.186	.250	1.18	.69	.25	.50	1.13	2.25	.250	.625	1.125
EJA500	1/2	.275	3/8	.875	.875	.250	.250	1.28	.78	.25	.56	1.38	2.75	.250	.625	1.125



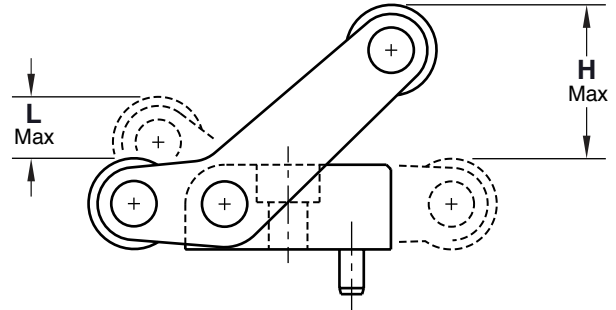
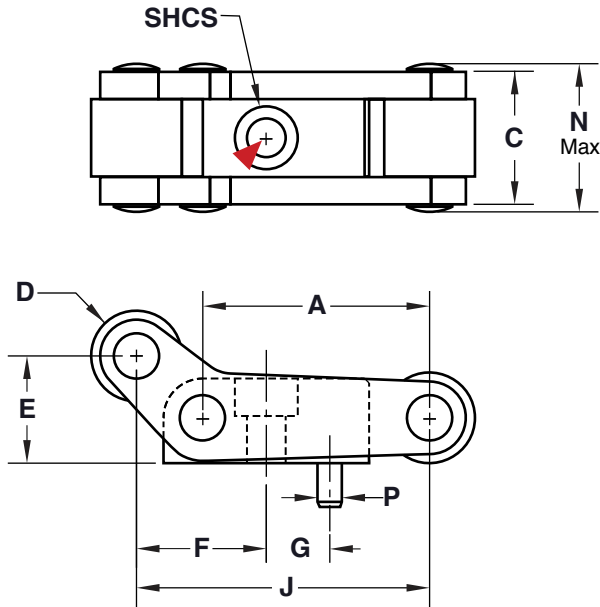
APPLICATION GUIDELINES

- Locate Stop Pin under dowel to return the Ejector Accelerator as shown in graphic. The assembly includes the Kicker Pin, but the Stop Pin is to be provided by the mold builder.
- The Kicker Pin can be replaced with a standard ejector pin for applications with a thicker pin plate.
- When using spacers on the forward stroke, place spacers centerline with the Kicker Pin.





PLATE ACCELERATORS



APPLICATION GUIDELINES

- Use two or four Plate Accelerators per mold.

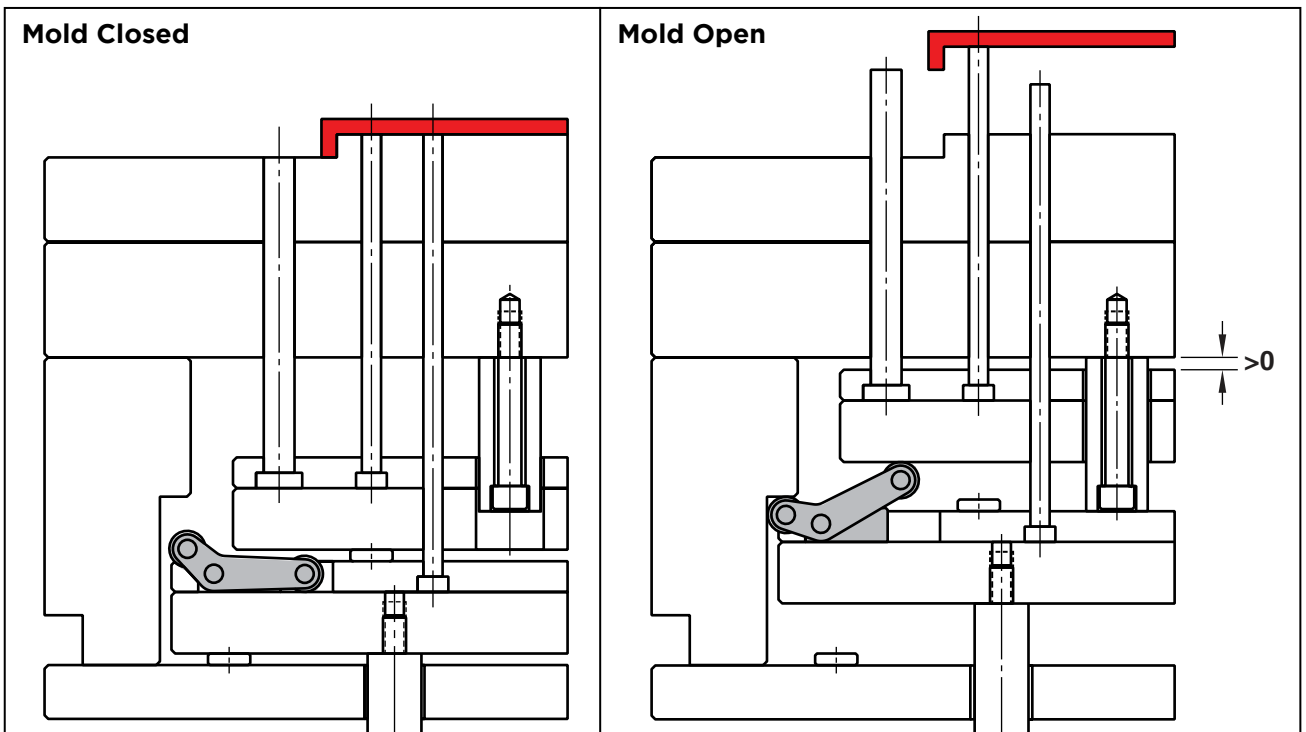
Arms: **M** H-13 **H** 46-50 HRC **S** Black Oxide

Roller: **M** 52100 **H** 56-60 HRC

▶ CAD insertion point

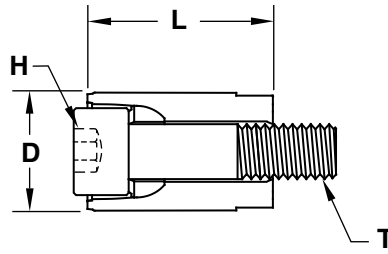
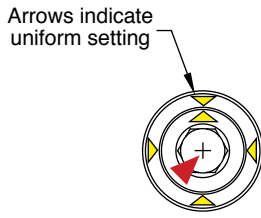
CATALOG NUMBER	A	L	H	D	E	F	G	J	C	N	P	SHCS	MAX FORCE (KG/LBS)
ACCPM20	20	4.4	11.6	8	9.4	11.4	6	25.8	13.2	15	Ø2.5x5	M3x12	125 / 275
ACCPM25	25	5.7	15	10	11.8	14.3	7	32.3	16	18.5	Ø3x6	M4x16	250 / 550
ACCPM37	37.5	9.1	22	15	17.7	21.5	10.5	48.5	22	25	Ø4x8	M6x25	350 / 770
ACCPM50	50	12.5	34	20	23.6	28.6	14	64.6	30	34	Ø5x10	M8x30	800 / 1,760

Screw and dowel included.



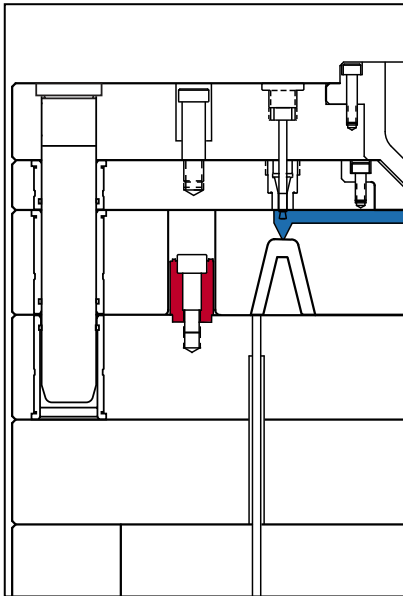
FRICTION PULLERS

PARTING LINE SEQUENCE CONTROL

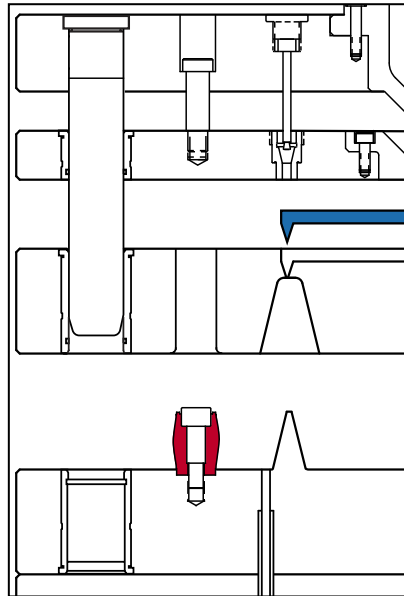


M Custom PPA Resin with 8620 Fastener ▶ CAD insertion point

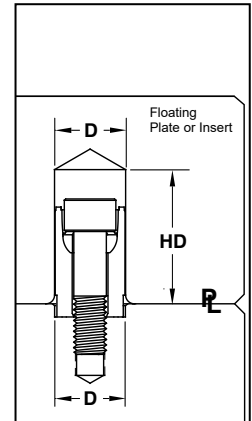
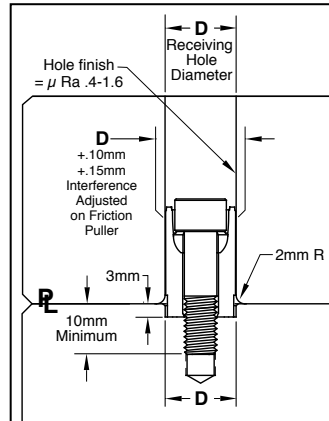
CATALOG NUMBER	D	L	T	H HEX	HD HOLE DEPTH	MAXIMUM FORCE (EA) (KG/LBS)
FP-10	10	17	M5-.8	3	20	32.5 / 70
FP-13	13	20	M6-1	4	23	62.5 / 135
FP-16	16	25	M8-1.25	5	30	150 / 330
FP-20	20	28	M10-1.5	6	32	212.5 / 470



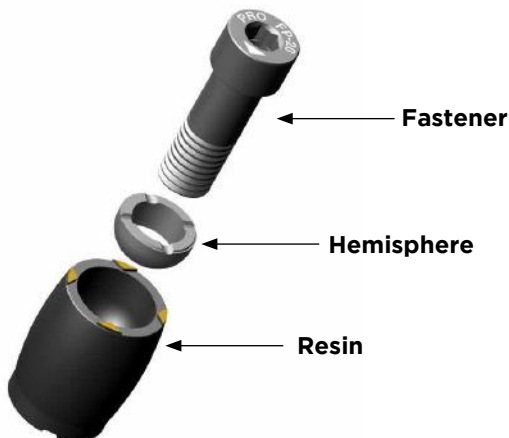
Mold Closed



Mold Open



Recommended interference fit is .1 to .15mm larger than the receiving hole. To adjust the Friction Puller, rotate the screw clockwise and measure bulge to achieve the proper fit. Further adjustments can be performed with 1/4 turn increments, lining up the reference arrows on the fastener to the resin.



APPLICATION GUIDELINES

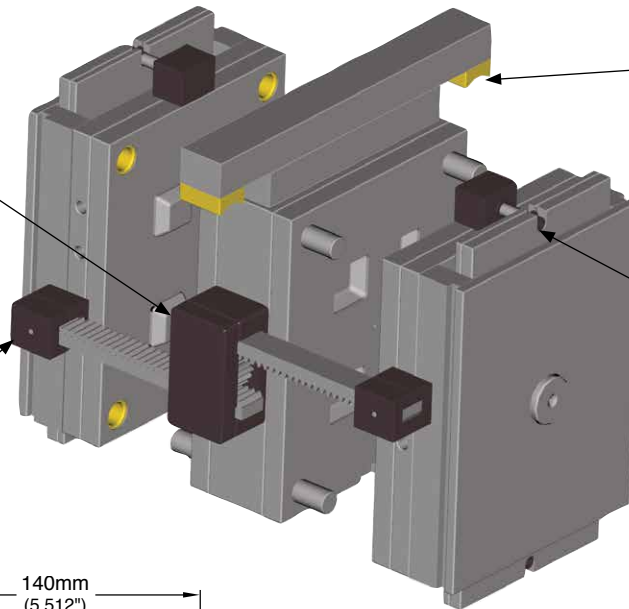
- Designed to replace shoulder bolts, the Friction Pullers initiate movement and utilize friction at a particular setting to release the plate when travel limits are reached.
- For mold maintenance, before removing the mold from the press, rotate the screw counter-clockwise 3/4 turn. This will allow easy separation of plates.
- Maximum operating temperature is 300°F (150°C).
- Fastener includes Nylok® patch for secure installation.
- The hemisphere is plated for additional lubricity during adjustments.
- Friction Pullers are self-venting. Additional venting not required when using blind holes.
- Replacement items are available. Contact Customer Service for more information.



STACKIT® STACK MOLD SYSTEM

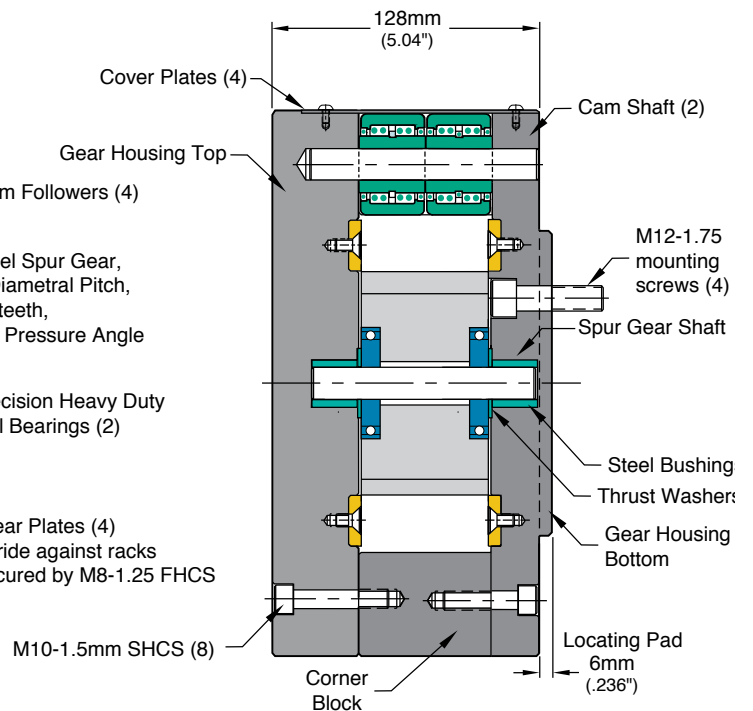
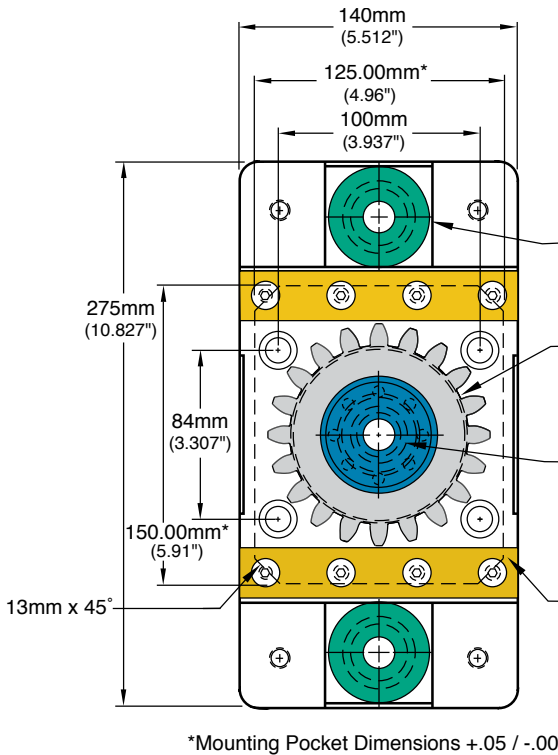
Center Positioning
Gear Housing Assembly maintains the position of the center section and protects gears and bearings from the molding elements.

Rack Spacers
Used for securing the gear racks to the movable halves.



Tie Bar Pads
Standard Tie Bar Pads are available with or without a machined radius or lubrication passages.

Ejection Actuation
Standard cylinders for actuating ejector plates, with standard couplings to eliminate any threading into plates.



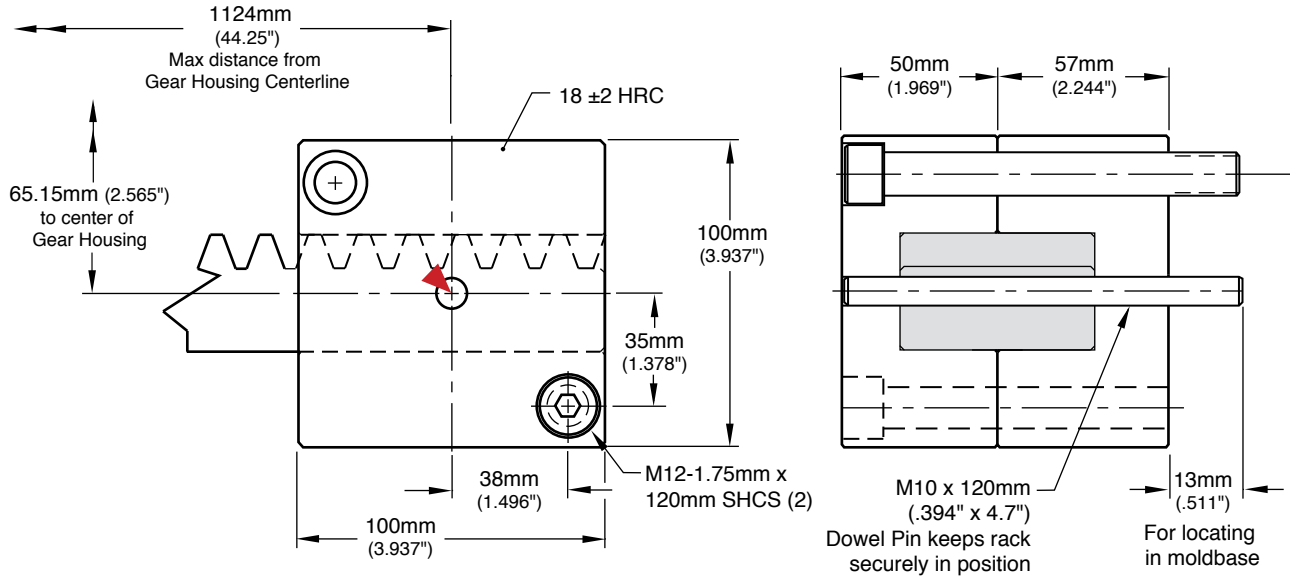
APPLICATION GUIDELINES

- Max center section effective weight per StackKit pair is 4,536kg (10,000lbs)
- Ensure mold is within maximum projected weight of molding machine.
- When mounting racks to a mold, ensure both sides are timed equally.
- Install two gear housings in center, as shown above. For large molds, four housings should be installed, two per side.

CATALOG NUMBER	DESCRIPTION
SK-GHA-250	Gear Housing Assembly
SK-SPGRKIT	Spur Gear Replacement Kit

The Spur Gear Replacement Kit contains (1) Spur Gear, (1) Cam Shaft, (2) Ball Bearings, (2) Thrust Washers, and (2) Steel Bushings.

STACKIT® RACK SPACERS



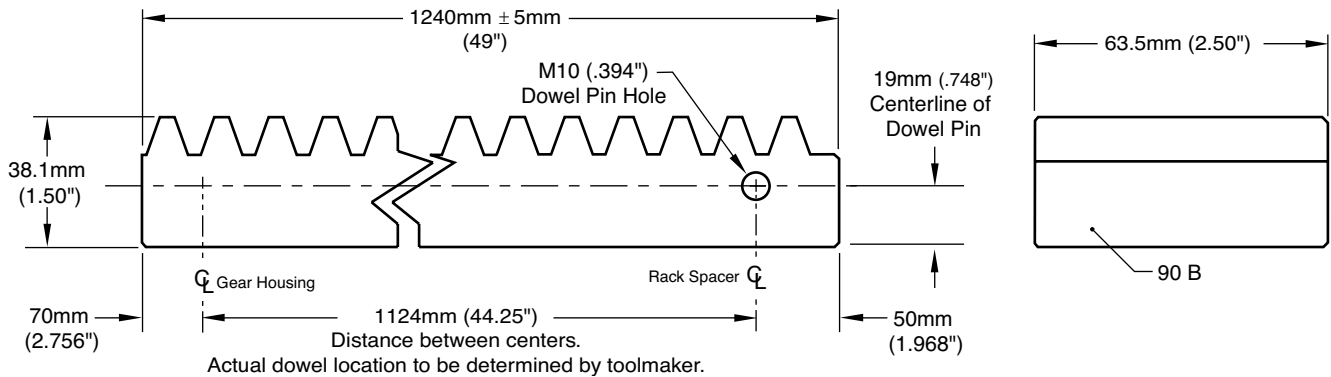
M A-36 **H** Pre-Hard **S** Black Oxide

▶ CAD insertion point

CATALOG NUMBER	DESCRIPTION
SK-RSA-250	Rack Spacer Assembly

Screws and locating dowel included.

STACKIT® RACKS



M CRS

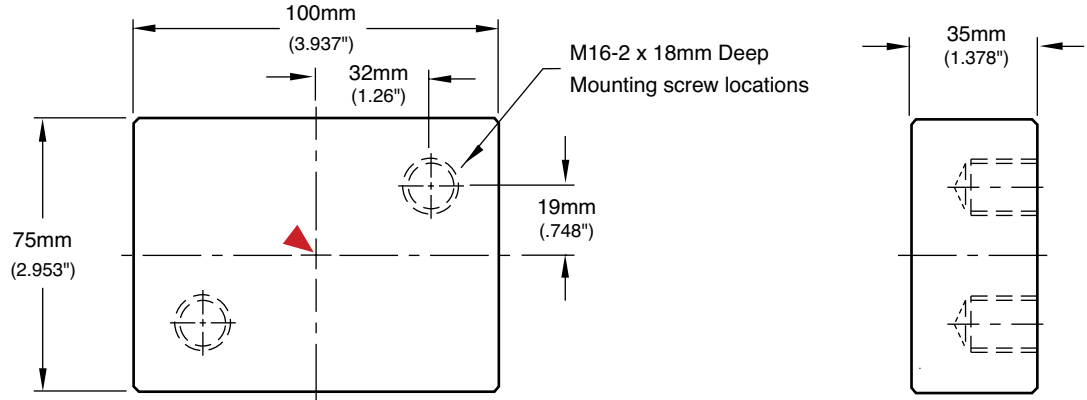
CATALOG NUMBER	DESCRIPTION
SK-RC-250	Rack (Sold Individually)



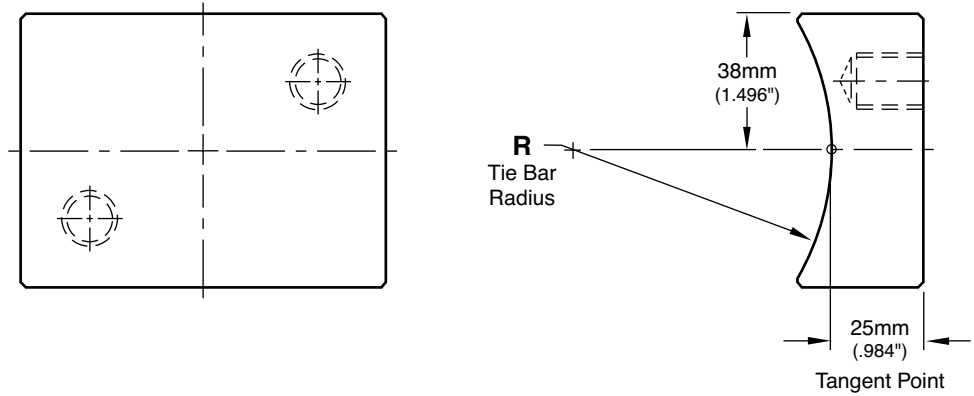
STACKIT® TIE BAR PADS



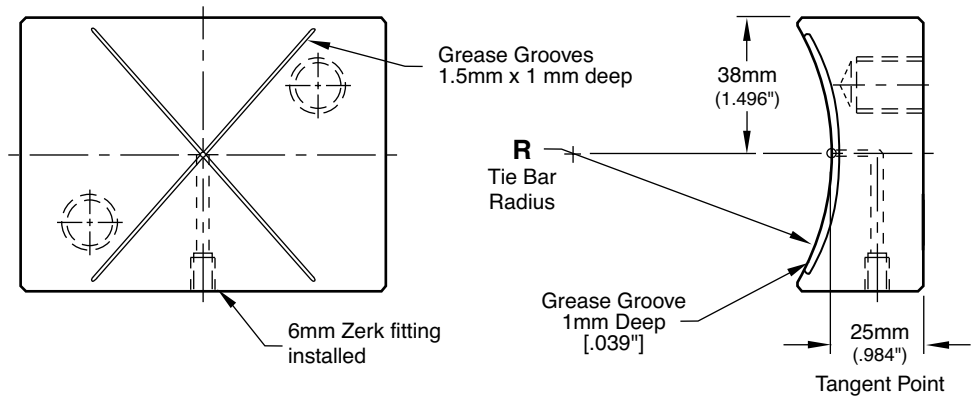
SK-TBP-35
Tie Bar Pad Blanks



SK-TBP-R
Tie Bar Pad with finished radius. Please specify “-R” when ordering.



SK-TBP-RG
Tie Bar Pad with finished radius, grease grooves, and zerk fitting. Please specify “-RG” when ordering.



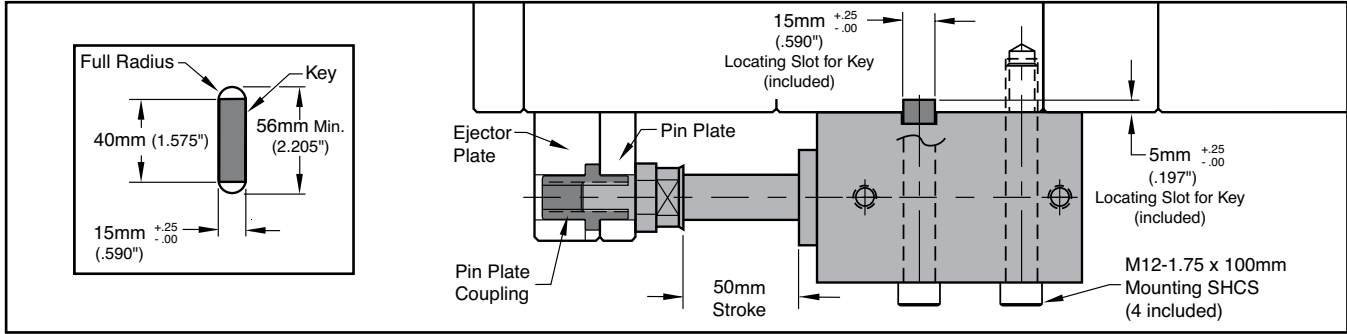
M CA954 Solid Bronze

▶ CAD insertion point

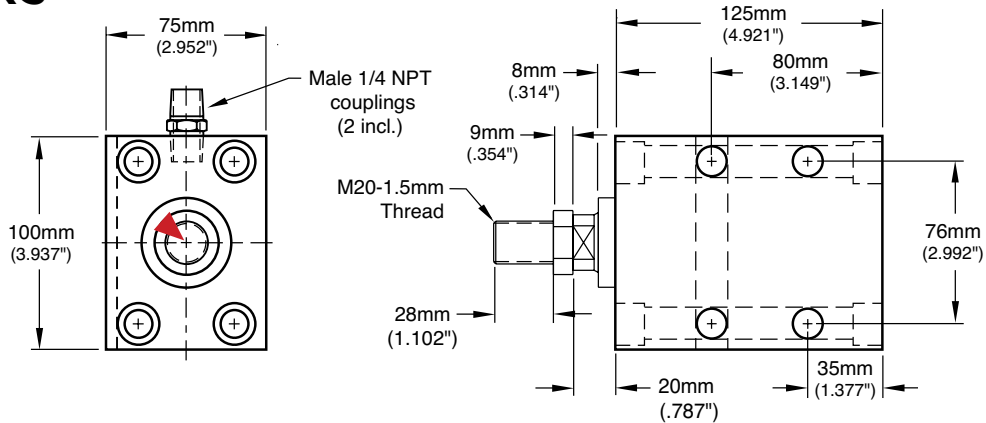
CATALOG NUMBER	DESCRIPTION
SK-TBP-35	Tie Bar Pad Blanks (No Radius)
SK-TBP-R	Tie Bar Pads with machined radius
SK-TBP-RG	Tie Bar Pads with machined radius, grease grooves and zerk fitting

Sold individually.

STACKIT® EJECTION ACTUATION



CYLINDERS



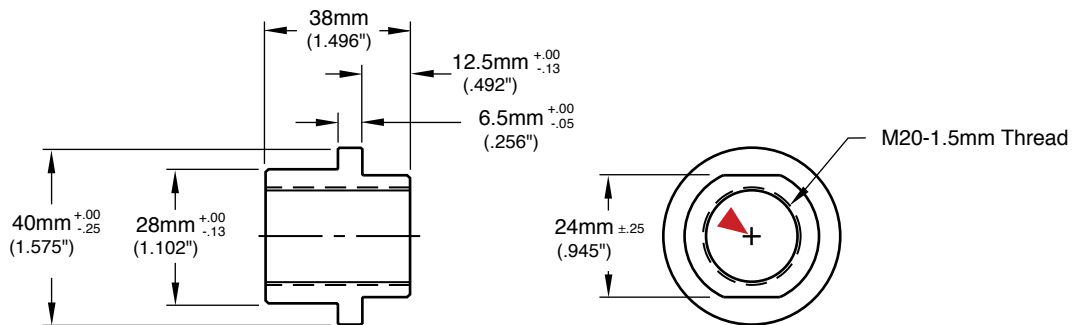
APPLICATION GUIDELINES

- 50mm (2") Stroke
- Rated up to 3200 psi
- Temperature: 220 °F (100 °C) max
- Includes (2) NPT couplings and Locating Key

▶ CAD insertion point

CATALOG NUMBER	DESCRIPTION
SK-CYL-50	50mm Block Cylinder

PIN PLATE COUPLINGS



M AISI 4140 **S** Black Oxide ▶ CAD insertion point

CATALOG NUMBER	DESCRIPTION
SK-PPC-20	M20-1.55mm Pin Plate Coupling



ELECTRICAL COMPONENTS

SECTION K



KO Switches	External Mount Switch	Plate Position Switch	Side Action Switch
Prefix: SWKO	Prefix: SWXM	Prefix: SWPPS	Prefix: SWSA
Page: K-1	Page: K-3	Page: K-4	Page: K-4



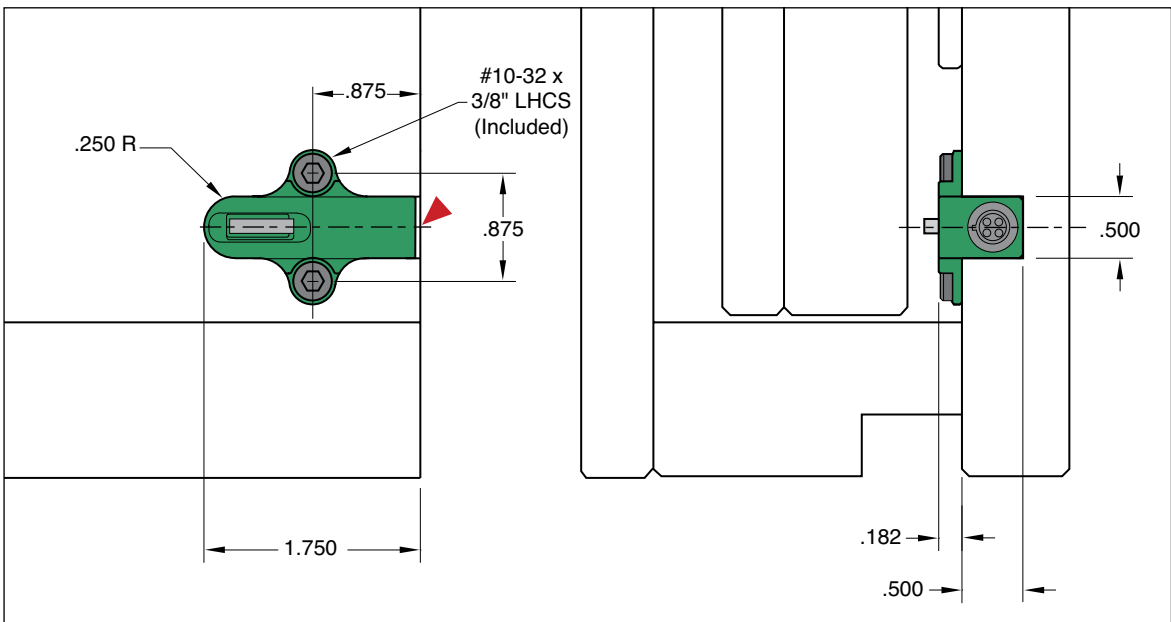
Patch Cables	Recessed Connectors	Thermocouples	Wire Channel Inserts
Prefix: ECCA	Prefix: ECRC	Prefix: TC	Prefix: WC
Page: K-6	Page: K-7	Page: K-7	Page: K-7



Hot Sprue Bushings
Prefix: BX
Page: K-8



SWITCHES
KO™ SWITCH



▶ CAD insertion point

GENERAL SPECIFICATIONS FOR SWITCHES		
	VOLTAGE	
	28 VDC	115 VAC 60 HZ
Resistive Load	300mA min / 5A max	300mA min / 5A max
Inductive Load	300mA min / 3A max	300mA min / 5A max
Mechanical Life	10 million cycles	10 million cycles
Max Temperature	221°F (105°C)	221°F (105°C)
Features:	Color-coded, keyed for specific function. Gold-plated contacts for switching logic level signals. Switches are wired normally open. Sealed and splash resistant. UL/CSA rating: 5A, 250 vac	

CATALOG NUMBER	COLOR	FUNCTION
SWKO-187	Green	Ejection

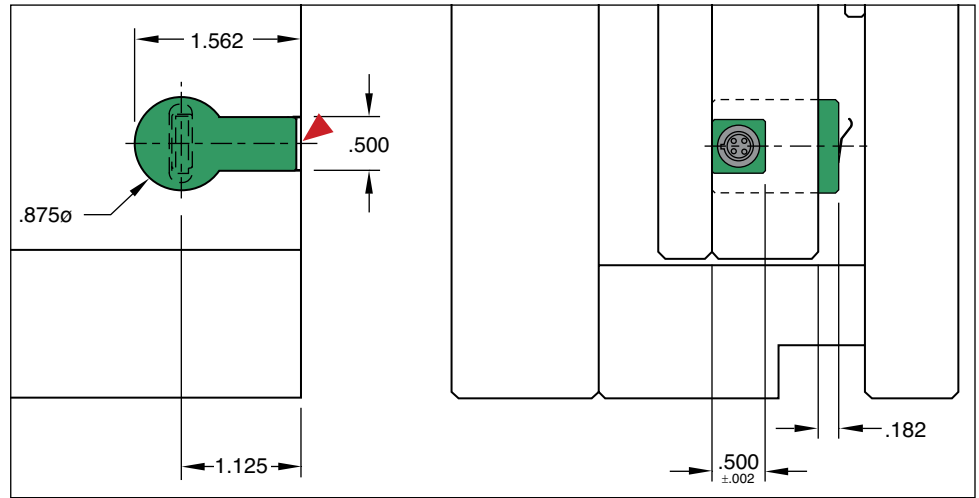
KO™ SWITCH CABLE



CATALOG NUMBER	COLOR	FUNCTION	ENDS	LENGTH (FT)
ECCA-6-20	Green	Ejector Switch	Male/Male	20
ECCA-6-20S	Green	Ejector Switch	Single Male	20

SWITCHES

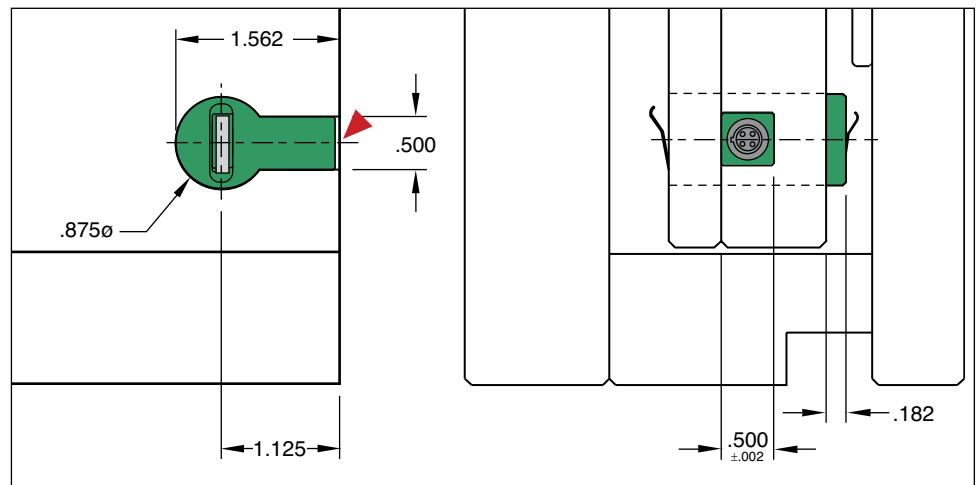
KO™ SWITCH: SINGLE EJECTOR



▶ CAD insertion point

CATALOG NUMBER	EJ. PLATE THICKNESS	COLOR	FUNCTION
SWKOS-100	1.000	Green	Ejection
SWKOS-112	1.125	Green	Ejection
SWKOS-118	1.187	Green	Ejection

KO™ SWITCH: DUAL EJECTOR



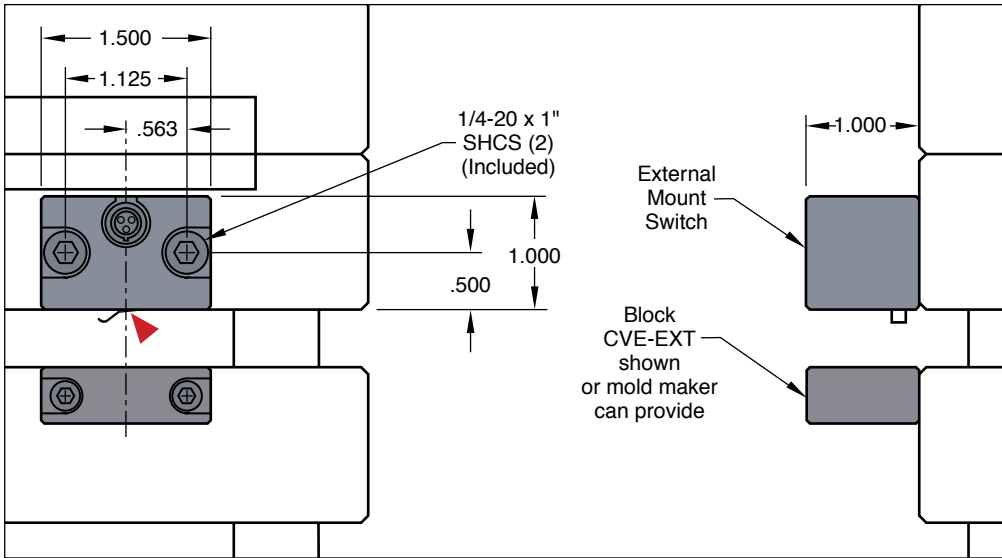
▶ CAD insertion point

CATALOG NUMBER	EJ. PLATE THICKNESS	RETAINER PLATE THICKNESS	COLOR	FUNCTION
SWKOD-100	1.000	.500	Green	Ejection
SWKOD-112	1.125	.500	Green	Ejection
SWKOD-118	1.187	.500	Green	Ejection



SWITCHES

EXTERNAL MOUNT SWITCH

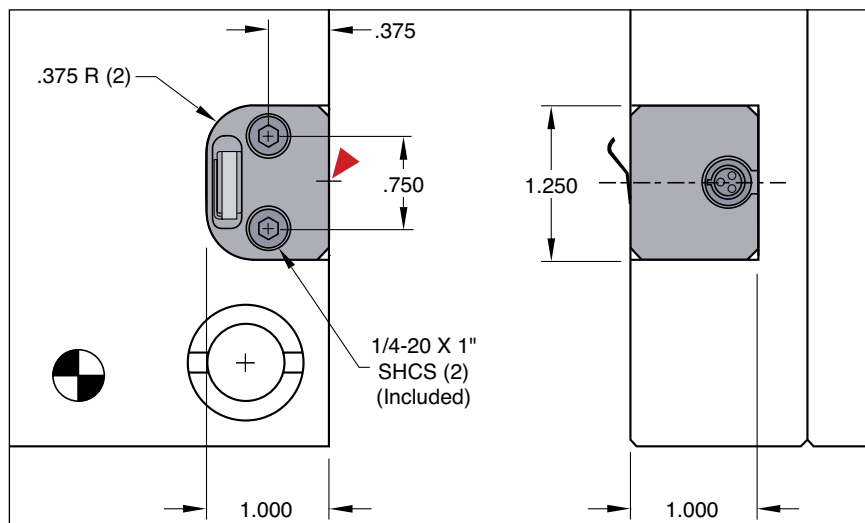


▶ CAD insertion point

CATALOG NUMBER	COLOR	FUNCTION / CABLE PREFIX
SWXM-3	Gray	Enable / ECCA-3

SWITCHES

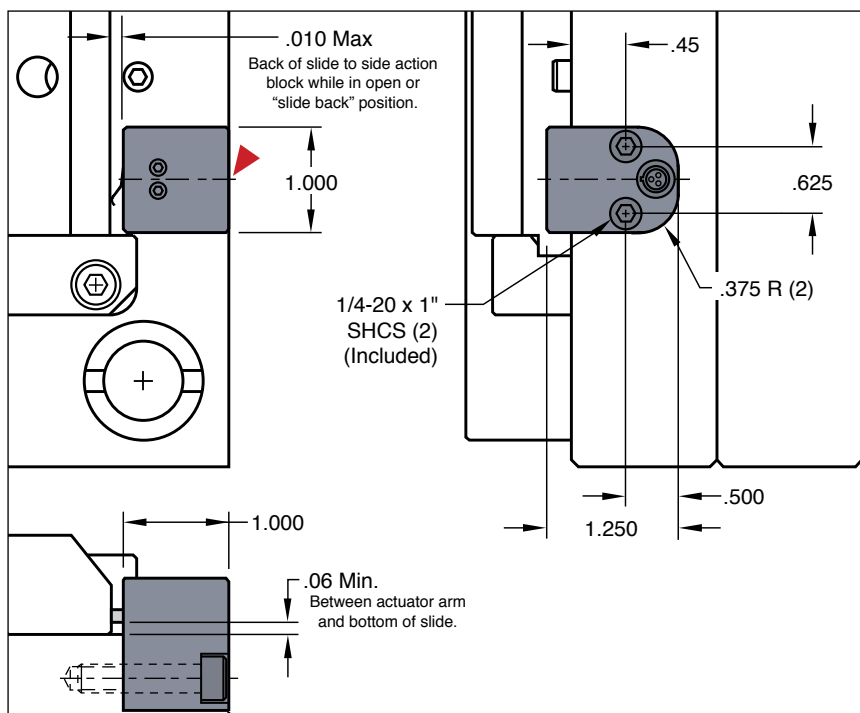
PLATE POSITION SWITCH



▶ CAD insertion point

CATALOG NUMBER	COLOR	FUNCTION / CABLE PREFIX
SWPPS-100	Gray	Enable / ECCA-3

SIDE ACTION SWITCH



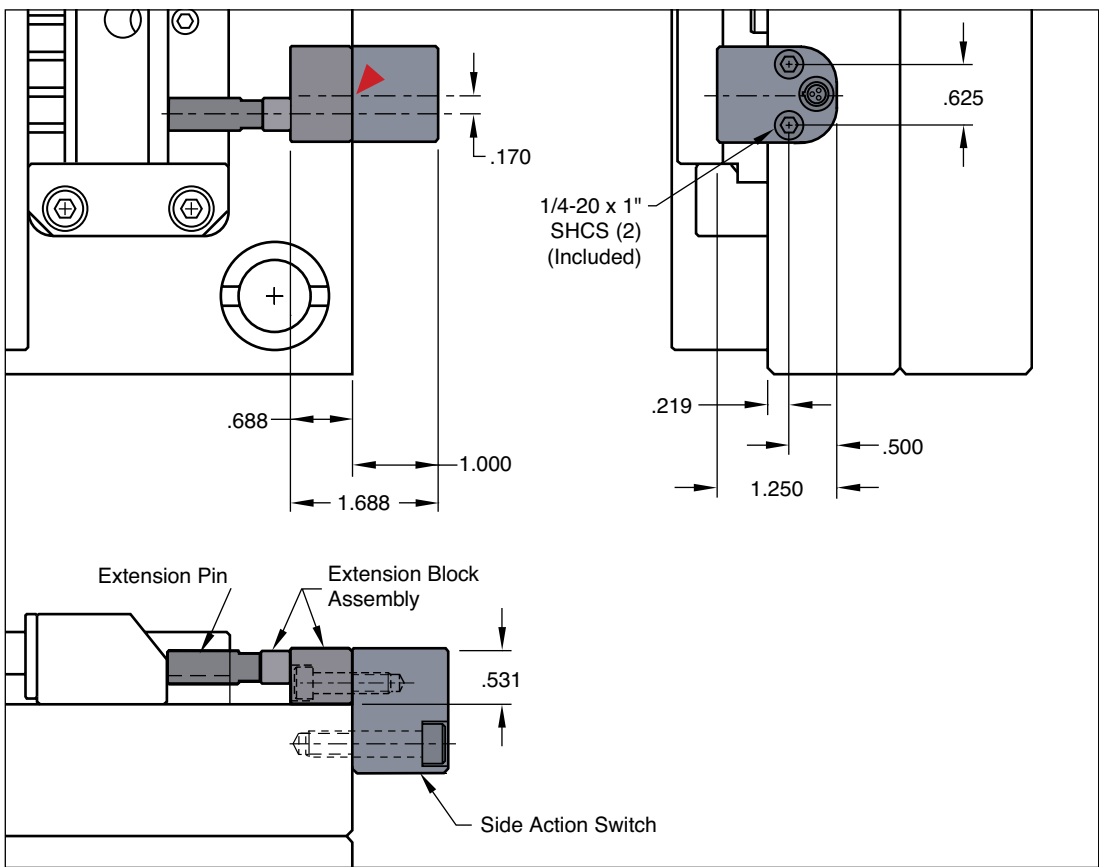
▶ CAD insertion point

CATALOG NUMBER	COLOR	FUNCTION / CABLE PREFIX
SWSA-100	Gray	Enable / ECCA-3

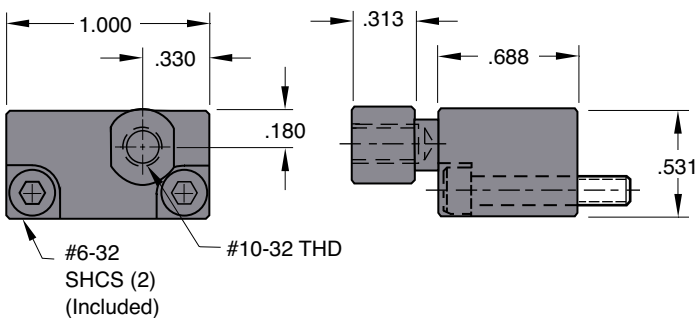


SWITCHES

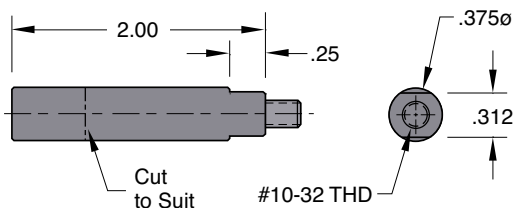
EXTENSION BLOCK ASSEMBLY



EXTENSION BLOCK ASSEMBLY



EXTENSION PIN



CAD insertion point

CATALOG NUMBER	DESCRIPTION
SWXB-100	Extension Block Assembly
SWEP-100	Extension Pin

PATCH CABLES



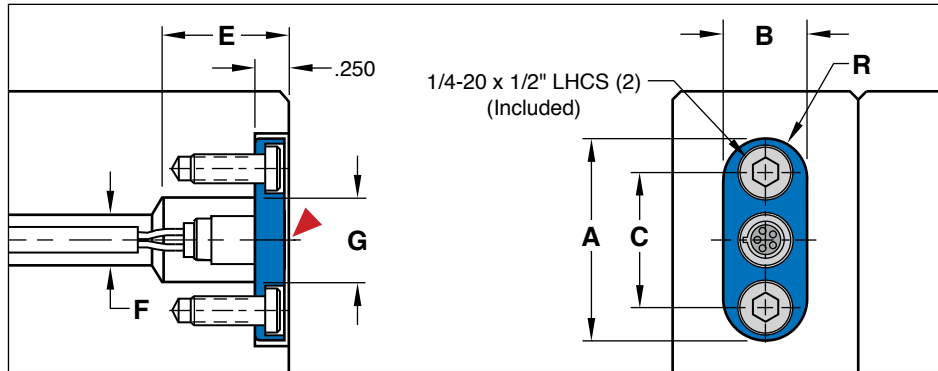
ECCA-1-10CC has a 5-pin hooded connector compatible with most standard single zone controllers.



ECCA-1-10LC connects the Hot Sprue Recessed Connector and most standard single zone controllers.

CATALOG NUMBER	COLOR	FUNCTION	ENDS	LENGTH (FT)
ECCA-1-20	Red	Hot Sprue	Male/Female	20
ECCA-1-20SF	Red	Hot Sprue	Single Female	20
ECCA-1-10CC	Red	Hot Sprue	5 Pin M/5 Pin F	10
ECCA-1-10LC	Red	Hot Sprue	5 Pin M/Female	10
ECCA-3-20	Gray	Enable	Male/Male	20
ECCA-3-20S	Gray	Enable	Single Male	20
ECCA-6-20	Green	Ejection	Male/Male	20
ECCA-6-20S	Green	Ejection	Single Male	20
ECCA-7-20	Orange/Blue	Stationary/Movable	Male/Male	20
ECCA-7-20S	Orange/Blue	Stationary/Movable	Single Male	20

RECESSED CONNECTORS



▶ CAD insertion point

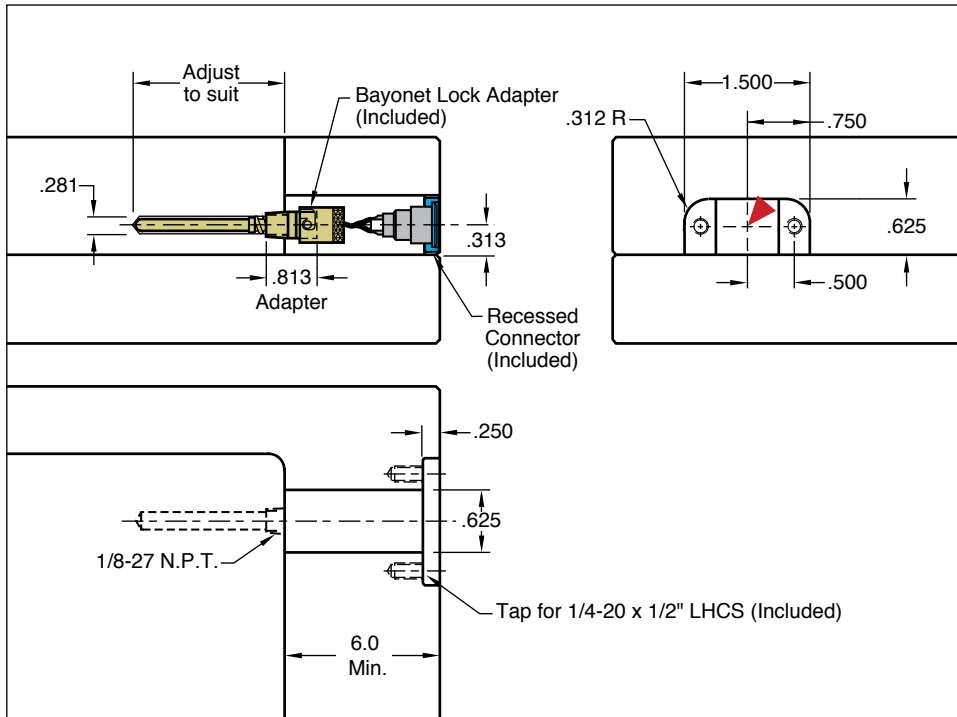
CATALOG NUMBER	COLOR	FUNCTION	PIN OUTS	A	B	C	R	E	F DIAMETER	G DIAMETER
ECRC-1	Red	Hot Sprue	5	2.000	1.00	1.500	.375	1.312	.500	1.00
ECRC-3	Gray	Enable	3	1.500	.625	1.000	.312	.937	.375	.625
ECRC-6	Green	Ejection	4	1.500	.625	1.000	.312	.937	.375	.625
ECRC-7	Orange	Stationary T/C	2	1.500	.625	1.000	.312	.937	.375	.625
ECRC-8	Blue	Movable T/C	2	1.500	.625	1.000	.312	.937	.375	.625

Note: As a safety precaution, the ECRC-1 for the Hot Sprues include a male plug, which is compatible with the ECCA-1-20SF female ended patch cable. Hot Sprue Bushings are sold on page K-8.

Crimp-style bullet snap connectors included.



THERMOCOUPLES



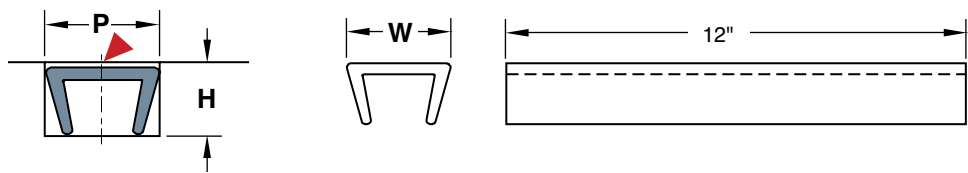
APPLICATION GUIDELINES

- Type "J"-Grounded
- 3/16" Diameter Ball Tip
- Maximum 750°F over probe
- 30" of wire included
- Maximum temperature of wire and connector: 220°F (104°C)
- Each Thermocouple assembly includes: Thermocouple, Bayonet Lock Adapter, Recessed connector, & Screws.
- Replacement Thermocouples (TC-100) and Bayonet Lock Adapters (TCA-100) are also available. Replacement Recessed Connectors sold on page K-6.

▶ CAD insertion point

CATALOG NUMBER	COLOR	FUNCTION / CABLE PREFIX
TC-7	Orange	Stationary Side TC / ECCA-7
TC-8	Blue	Movable Side TC / ECCA-7

WIRE CHANNEL INSERTS



M Nylon

▶ CAD insertion point

CATALOG NUMBER	P POCKET WIDTH	H POCKET DEPTH	W WIRE CHANNEL WIDTH
WC-50	.550	.500	.564 ±.01
WC-100	1.000	.688	1.021 3.02

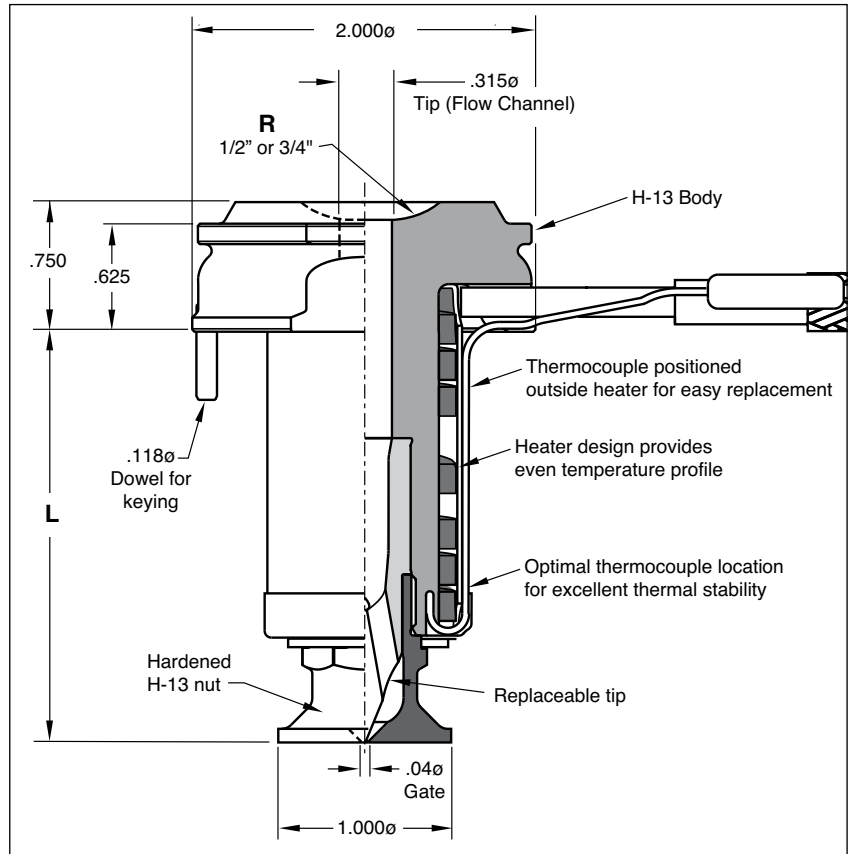
HOT SPRUE BUSHINGS INCH SERIES



Progressive's BX Inch Series Hot Sprue Bushings are designed as an advancement from previous Hot Sprue technology. This bushing's heater design and thermocouple placement provide excellent temperature distribution and thermal stability, resulting in superior performance both at start-up and during production, increased reliability, and easier maintenance.

Existing tools will benefit by replacing cold sprues, inefficient hot sprues, or applications used to feed cold runner systems.

Engineered and manufactured for Progressive by Mastip™ Technology Ltd.



To Order:

Specify all options within catalog number as shown:

Radius Options:

- 1/2" Specify - **50**
- 3/4" Specify - **75**

Nut Options:

- Standard Length (.080) Specify - **SL**
- Extra Stock (+.250) Specify -**XS**
- Sprue Picker (+1.250) Specify - **SP**

Tip Options:

- Nickel-Plated Be/Cu Tip: Used for unfilled commodity thermoplastics with a maximum temperature of 570°F (300°C) Specify -A for Nickel-Plated Be/Cu
- Carbide Tip: Ideal for engineered filled polymers with high temperature requirements. This Tungsten Carbide tip with Titanium Nitride coating was developed to process abrasive or polymers with fillers like glass, carbon, or talc. Specify -C for Carbide Tip

PREFIX/LENGTH	L	WATTS
BX25137	1.375	295
BX25187	1.875	350
BX25237	2.375	455
BX25287	2.875	490
BX25337	3.375	505

BX25187 50 SL C
Prefix/Length Radius Nut Tip Material

Example: BX25237-75-SP-A or BX25337-50-XS-C

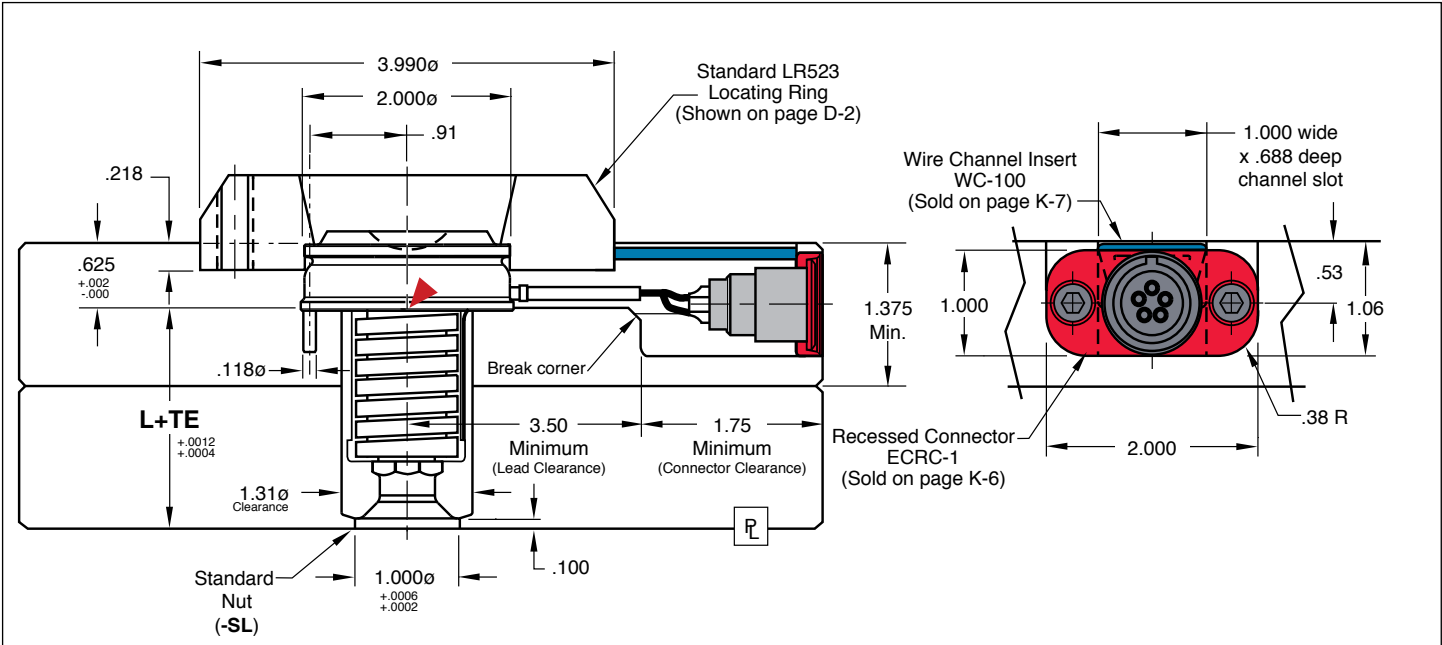
Each Hot Sprue Bushing Assembly includes:

- Body, Tip, Nut, Thermocouple and wiring.
- Cables (ECCA-1) are shown on page K-6.

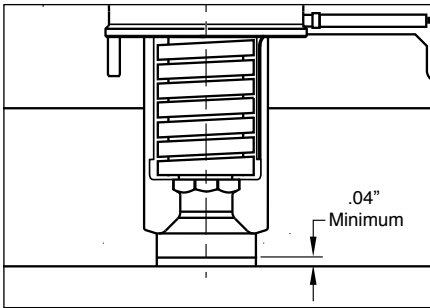
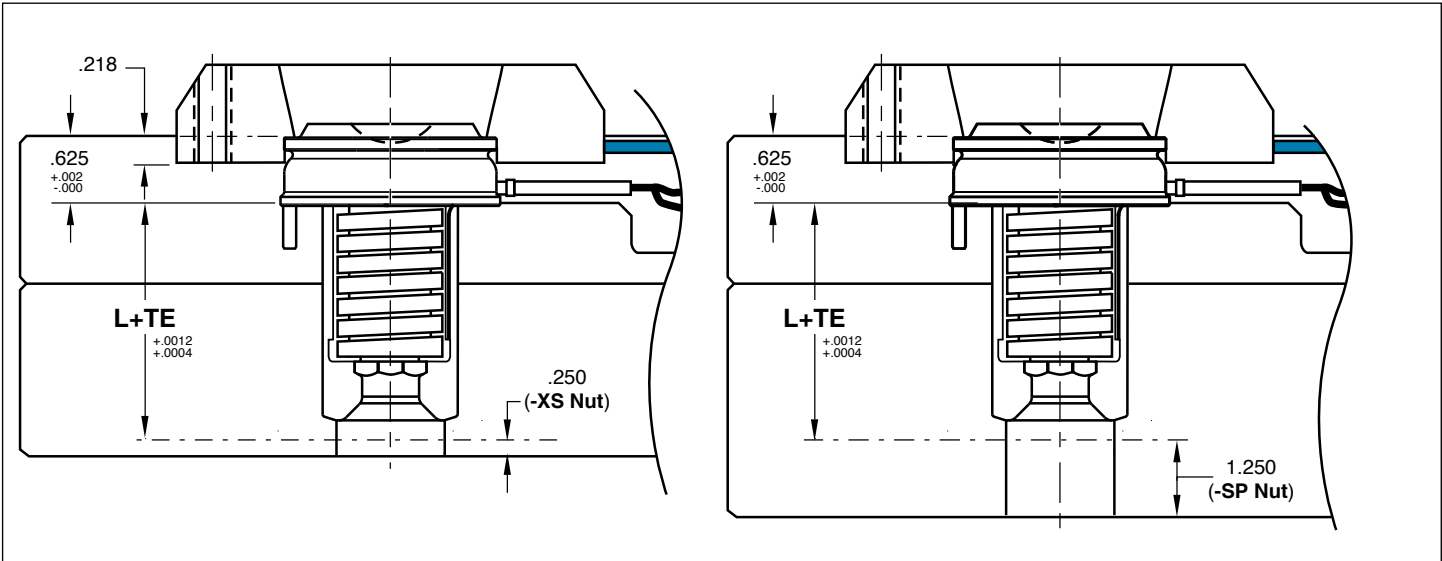


HOT SPRUE BUSHINGS INSTALLATION

Typical installation instructions:



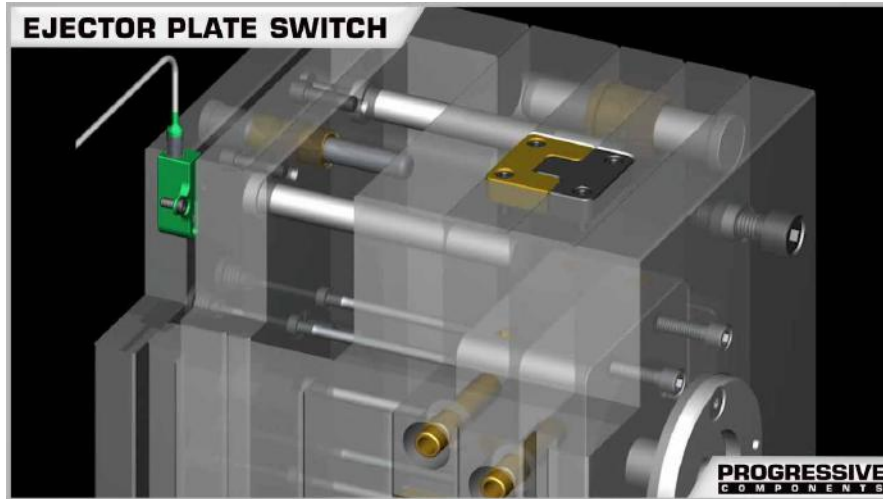
Longer Nut Installation Instructions:



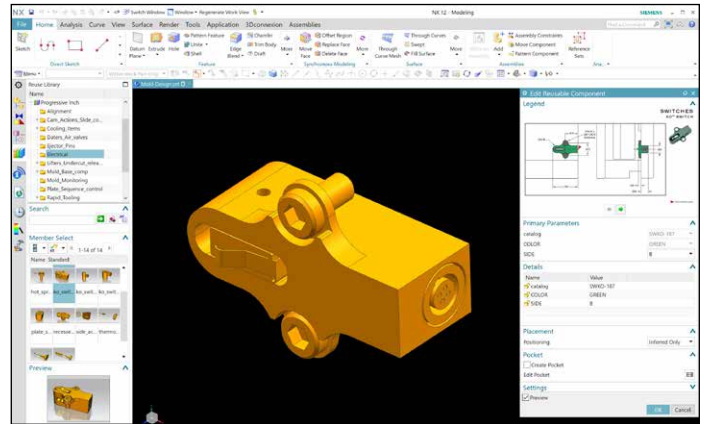
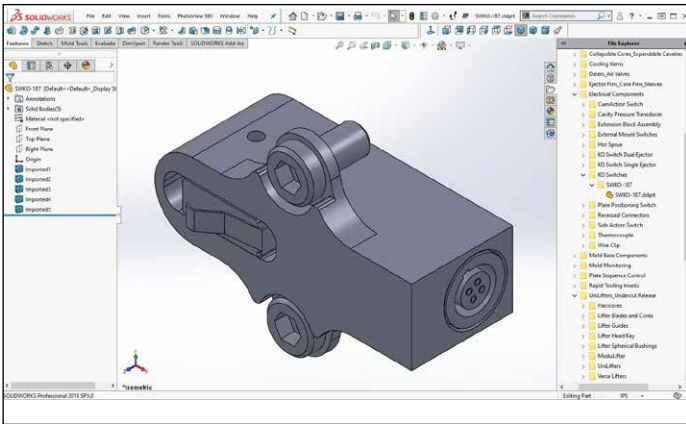
APPLICATION GUIDELINES

- To ensure optimal performance, design for a minimum .04" gap between the face of the bushing nut and "B" side of the mold after thermal expansion when gating into a cold runner.
- Expansion formula (TE):
 $.000007 \times (\text{Processing Temp } ^\circ\text{F} - \text{Mold Temp } ^\circ\text{F}) \times \text{L}$
- 230 volt-15 amps
- "J" type thermocouple

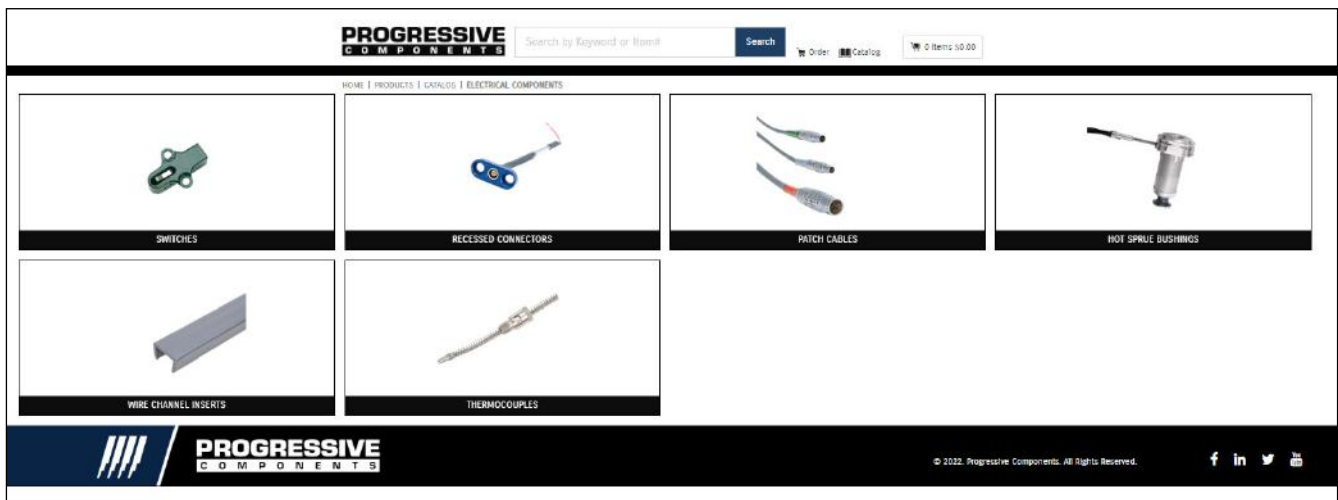
ONLINE RESOURCES



When considering design options, numerous animations can be viewed at procomps.com/animations.



CAD geometry is available online as individual downloads or as part of the CADalog system. The seven formats include: IGES (.igs), ACIS (.sat), STEP (.step), Parasolid (.x_t), SolidWorks (.sldasm), NX (.prt) (Re-Use and MoldWizard) and Visi (.wkf).

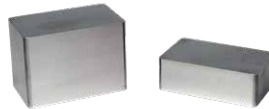


Industry-leading web store expedites the purchasing process. Go to shop.procomps.com for information and additional resources.



RAPID TOOLING INSERTS

SECTION L



Rapid Tooling Inserts	RTI: Complete	Cavity & Core Inserts	Frames
Prefix: RTS, RTL, RTT	Prefix: RTLP	Prefix: RCI, RCIA	Prefix: RTF
Page: L-2 - L-6	Page: L-4	Page: L-5	Page: L-7



Pins & Bushings	Frame Sprue Bushing	Support Pillars	Straps
Prefix: RLP, RSB, RGEB	Prefix: RFS	Prefix: RSP	Prefix: MS
Page: L-8	Page: L-9	Page: L-9	Page: L-10



Frame Clamp	T-Handle
Prefix: RFC	Prefix: T
Page: L-10	Page: L-10

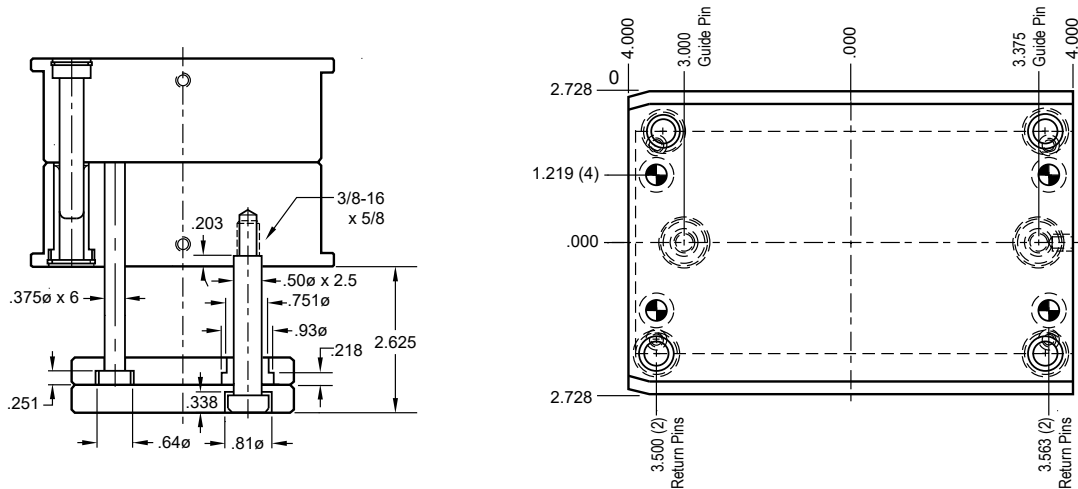


RAPID TOOLING INSERTS®

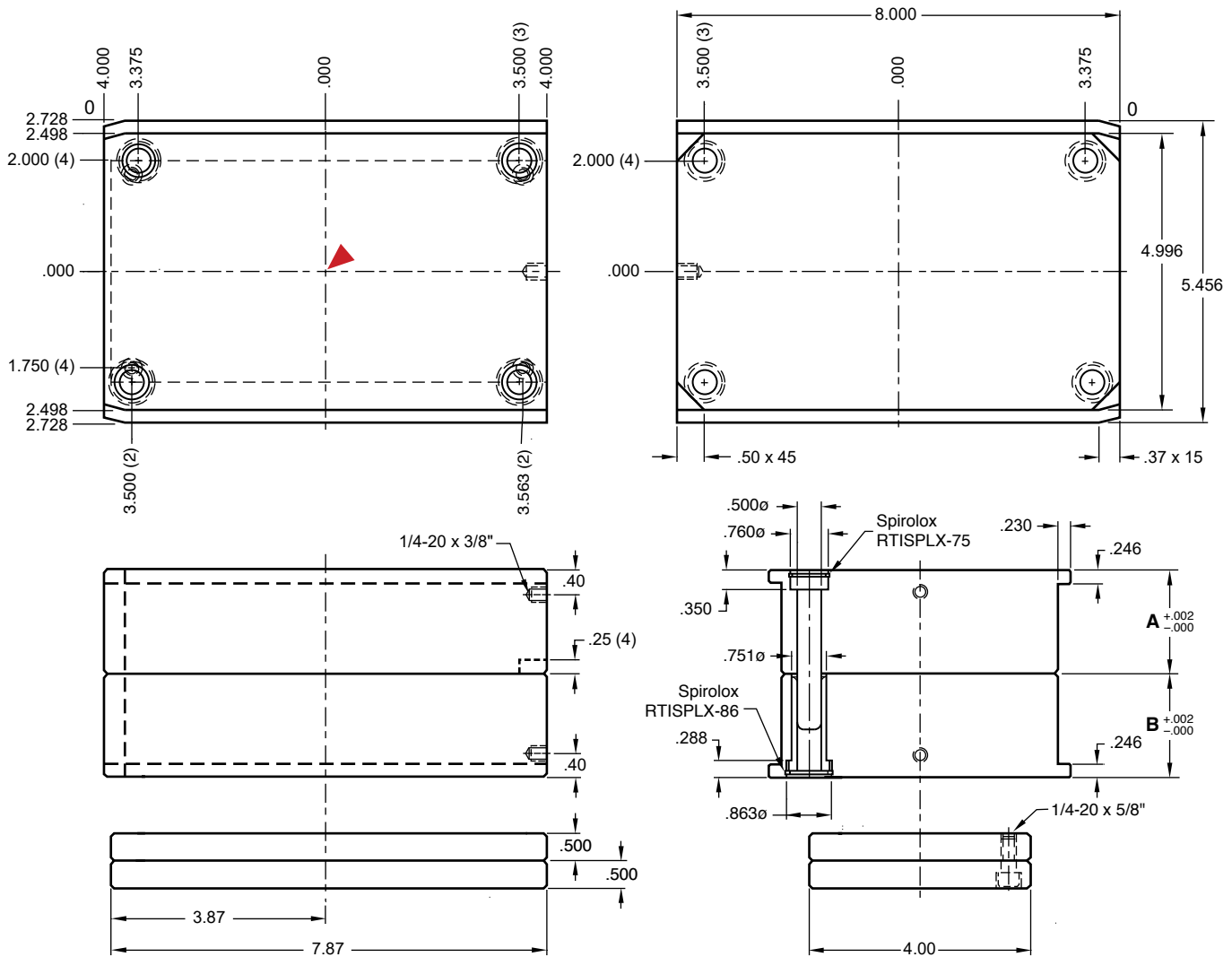


Guide Pins and Bushings:

Rapid Tooling Inserts can include Guide Pins and Bushings and Return Pins at standard Progressive locations below on the 08/09 Solid (shown), Laminated, and T-Style Inserts. See individual pages for ordering information.



RTI® 08/09 SERIES
5 X 8 SOLID



To Order:
 Specify the catalog number at right. Includes Leader Pins, Bushings, all screws, and mold strap/thumb screws.

ALTERNATIVE CONFIGURATIONS AVAILABLE

- With Guide Pins and Bushings (2) and Return Pins (4) machined and included, specify the catalog number at right with “-RPGPB” as the suffix. Refer to page L-1 for the default locations. Ex. RTS0809-1818-RPGPB.
- Stainless Steel: To order the stainless steel assembly, specify the item code in the chart at right. This assembly includes Guide Pins, Bushings, and Return Pins standard.

M All plates are P-20 Pre-Hard

CATALOG NUMBER	A	B
RTS0809-1818	1.876	1.876
RTS0809-1823	1.876	2.376

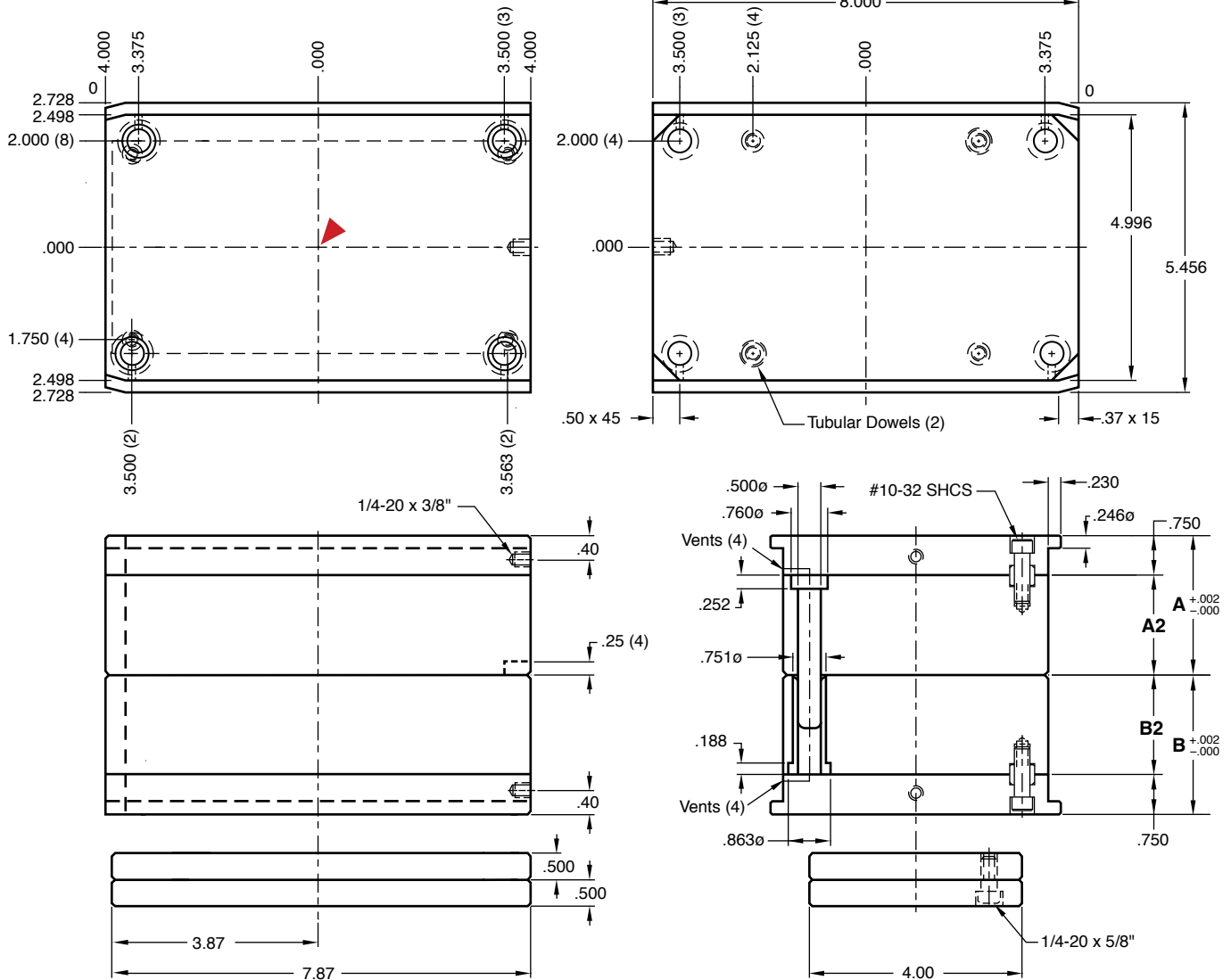
M All plates are 420 Stainless Steel

CATALOG NUMBER	A	B
RTS08091818-RPGPB-SS	1.876	1.876

▶ CAD insertion point



RTI® 08/09 SERIES
5 X 8 LAMINATED



To Order:
Specify the catalog number at right. Includes Leader Pins, Bushings, all screws, and mold strap/thumb screws.

ALTERNATIVE CONFIGURATIONS AVAILABLE

- With Guide Pins and Bushings (2) and Return Pins (4) machined and included, specify the catalog number at right with "-RPGPB" as the suffix. Refer to page L-1 for the default locations. Ex. RTL0809-1818-RPGPB.
- Stainless Steel: To order the stainless steel assembly, specify the item code in the chart at right. This assembly includes Guide Pins, Bushings, and Return Pins standard.

M All plates are P-20 Pre-Hard

CATALOG NUMBER	A	A2	B	B2
RTL0809-1818	1.876	1.126	1.876	1.126
RTL0809-2323	2.376	1.626	2.376	1.626

M All plates are 420 Stainless Steel

CATALOG NUMBER	A	A2	B	B2
RTL08092323-RPGPB-SS	2.376	1.626	2.376	1.626

▶ CAD insertion point

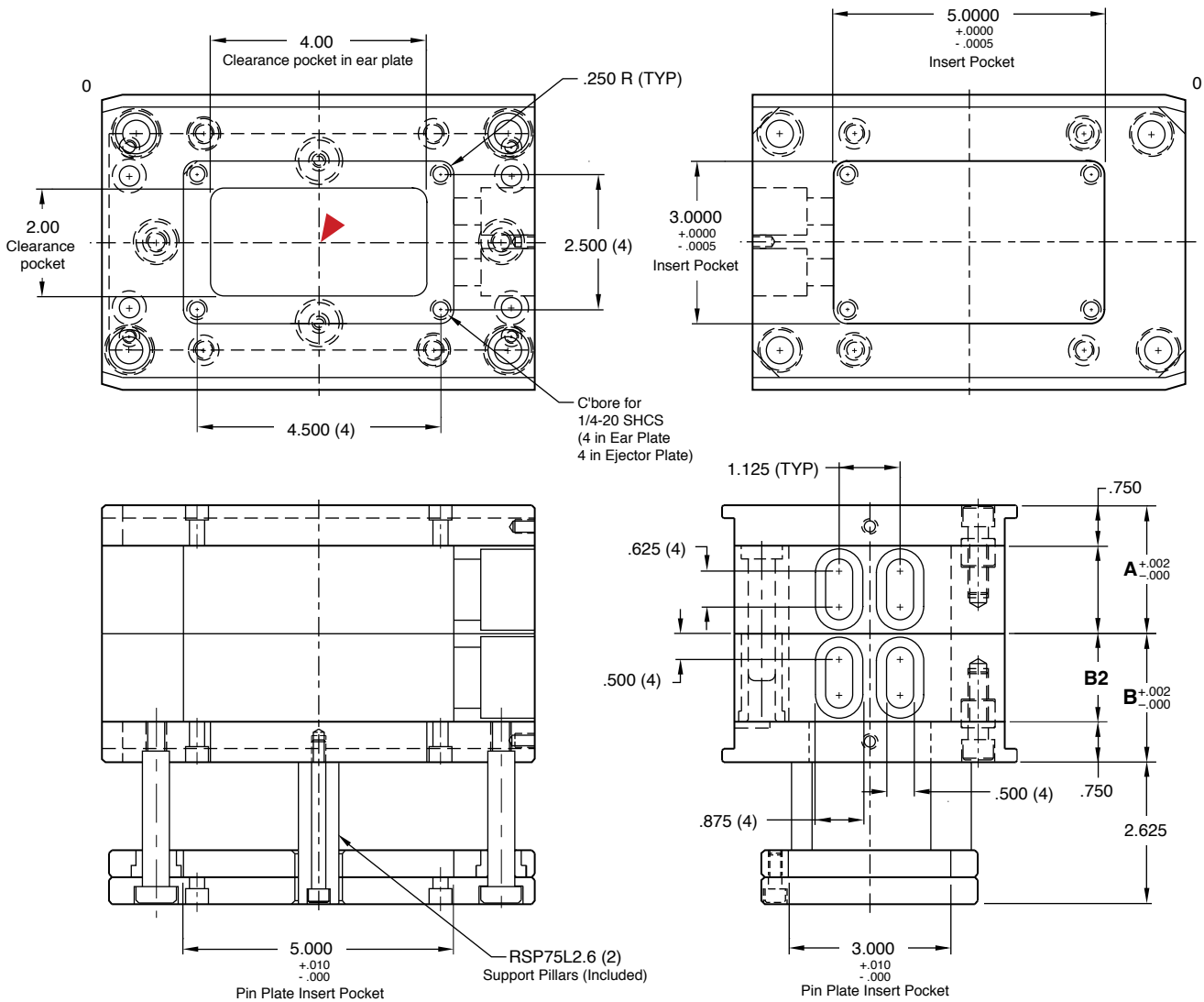
RTI COMPLETE



Rapid Tooling Inserts are available with pre-machined pockets for core and cavity inserts. Also, the pin plate area is pocketed for complete quick tooling changes.

Size: 08/09 Series, 5x8 Laminated unit. Full specs are shown on page L-3.

Cavity, core, and pin plate inserts are available on page L-5.



M A & B Plates: P-20 Pre-Hard, Ear Plates: AISI 4130, Pin Plates: AISI 1018

CATALOG NUMBER	A	A2	B	B2
RTLTP-0809-2323-P	2.376	1.626	2.376	1.626

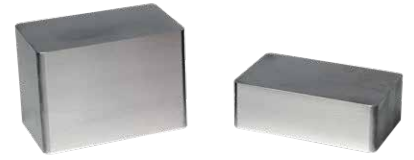
▶ CAD insertion point



RTI COMPLETE CORE AND CAVITY INSERTS

DH2F, Modified H-13 40-42 HRC

This through-hardened material requires no additional heat treatment and is ready for machining of cavity and core details.

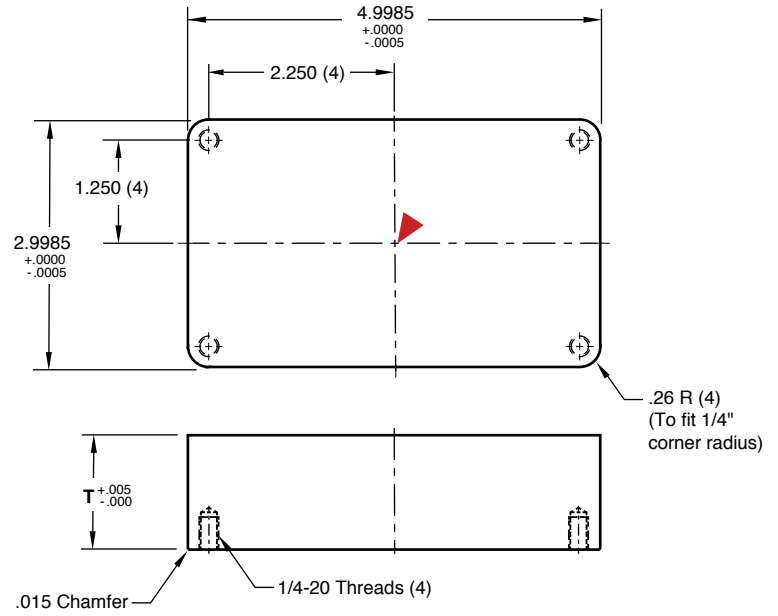


CATALOG NUMBER	T
RCI-0809-16	1.630
RCI-0809-35	3.500

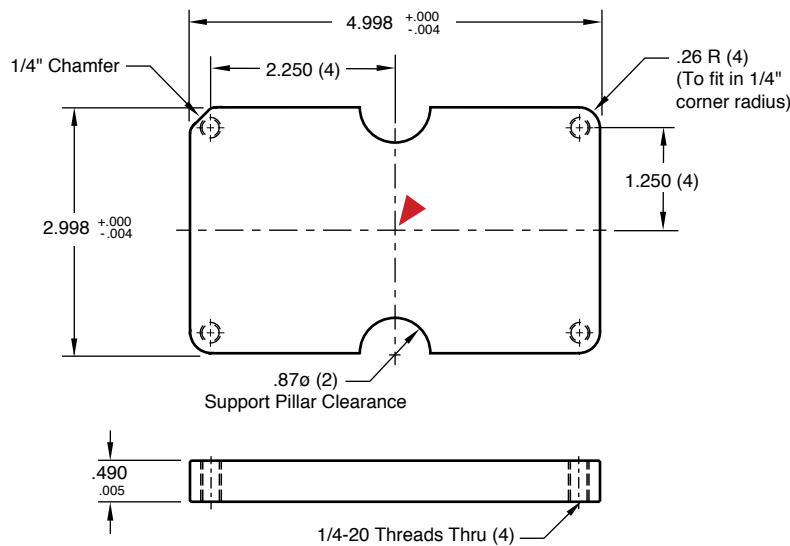
QC-10, Aluminum Alloy 155-170 Brinell

This aluminum material has excellent machinability, allowing faster cutting speeds for prototype tools which are not subjected to abrasive plastics.

CATALOG NUMBER	T
RCIA-0809-16	1.630
RCIA-0809-35	3.500



PIN PLATE INSERTS



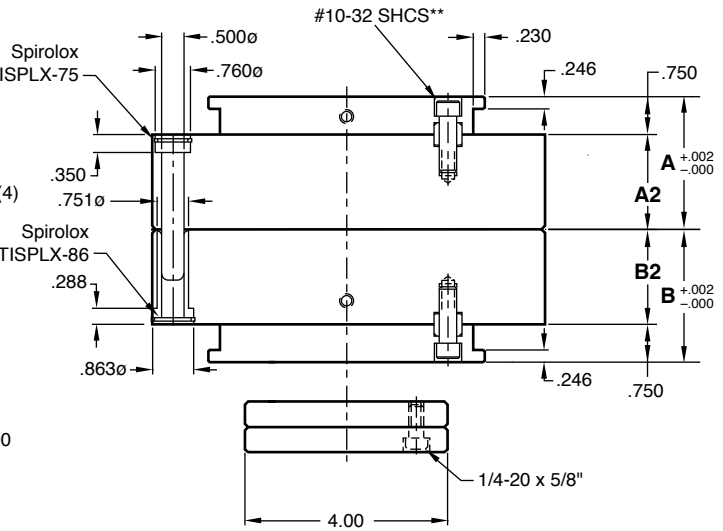
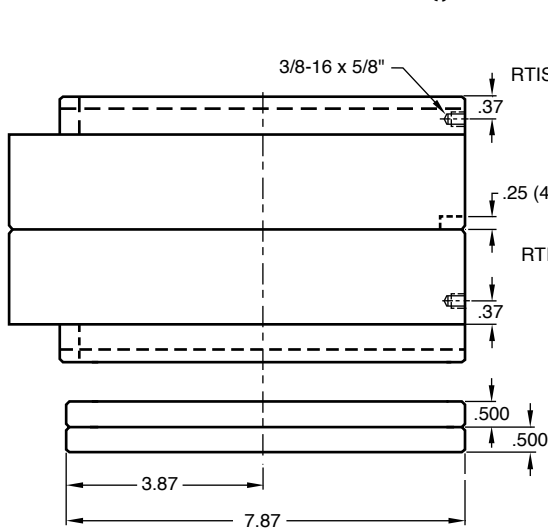
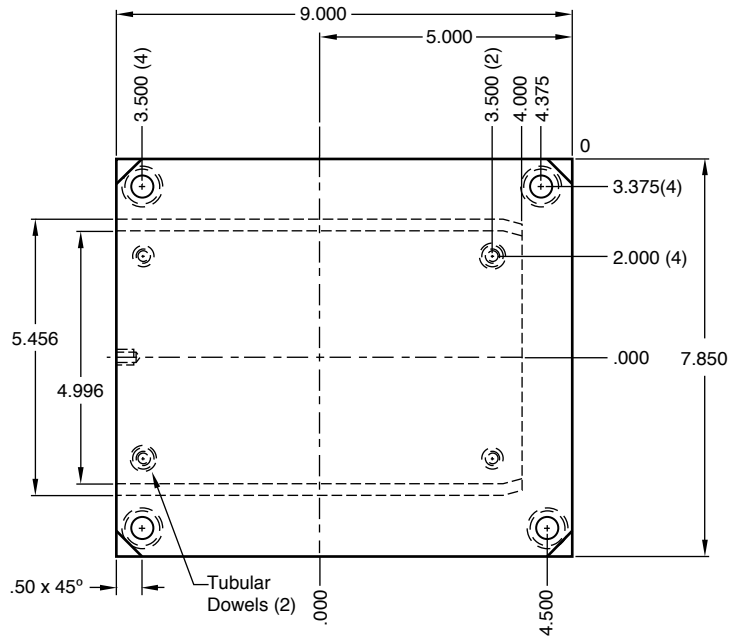
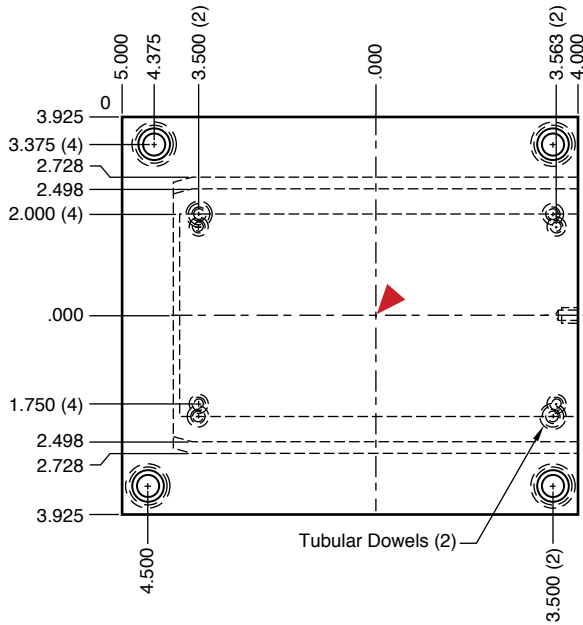
M AISI 1018

CAD insertion point

CATALOG NUMBER	DESCRIPTION
RPI-0809-5	Pin Plate Insert

RTI® 08/09 SERIES
7.85 X 9 T-STYLE

Note: Offset zero location.



**RTT0809-2222 & -2626 have 1/4-20 SHCS

To Order:

Specify the catalog number at right. Includes Leader Pins, Bushings, all Screws, and MS65 Mold Strap and Screws.

ALTERNATIVE CONFIGURATIONS AVAILABLE

- With Guide Pins and Bushings (2) and Return Pins (4) machined and included, specify the catalog number at right with "-RPGPB" as the suffix. Refer to page L-1 for the default locations. Ex. RTT0809-2222-RPGPB.
- Stainless Steel: To order the stainless steel assembly, specify the item code in the chart at right. This assembly includes Guide Pins, Bushings, and Return Pins standard.

M All plates are P-20 Pre-Hard

CATALOG NUMBER	A	A2	B	B2
RTT0809-2222	2.251	1.501	2.251	1.501
RTT0809-2626	2.626	1.876	2.626	1.876

M All plates are 420 Stainless Steel

CATALOG NUMBER	A	A2	B	B2
RTT08092222-RPGPB-SS	2.251	1.501	2.251	1.501

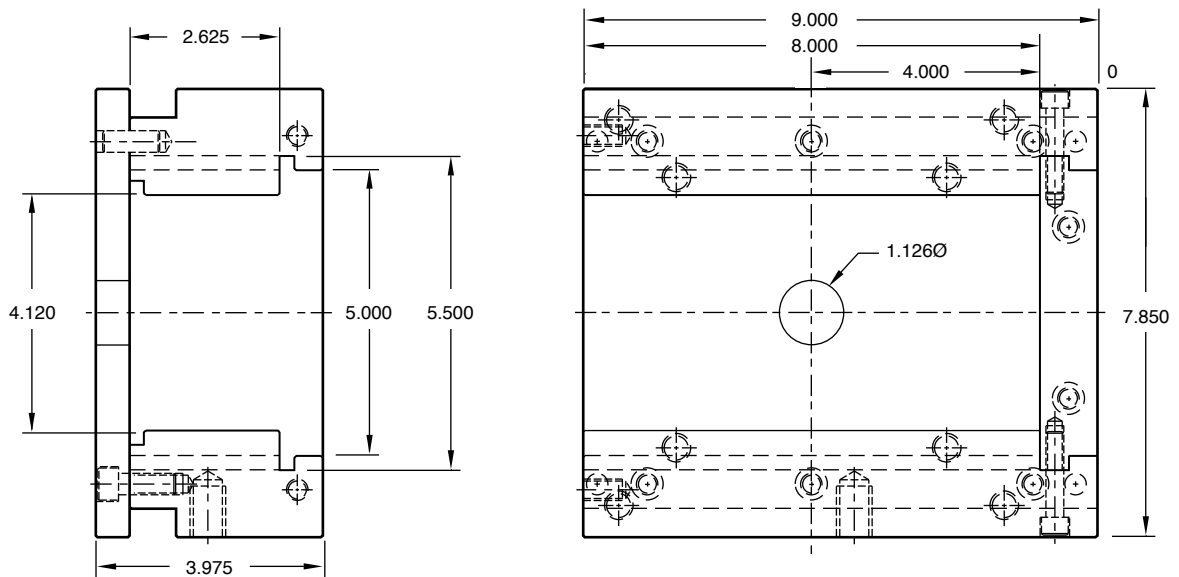
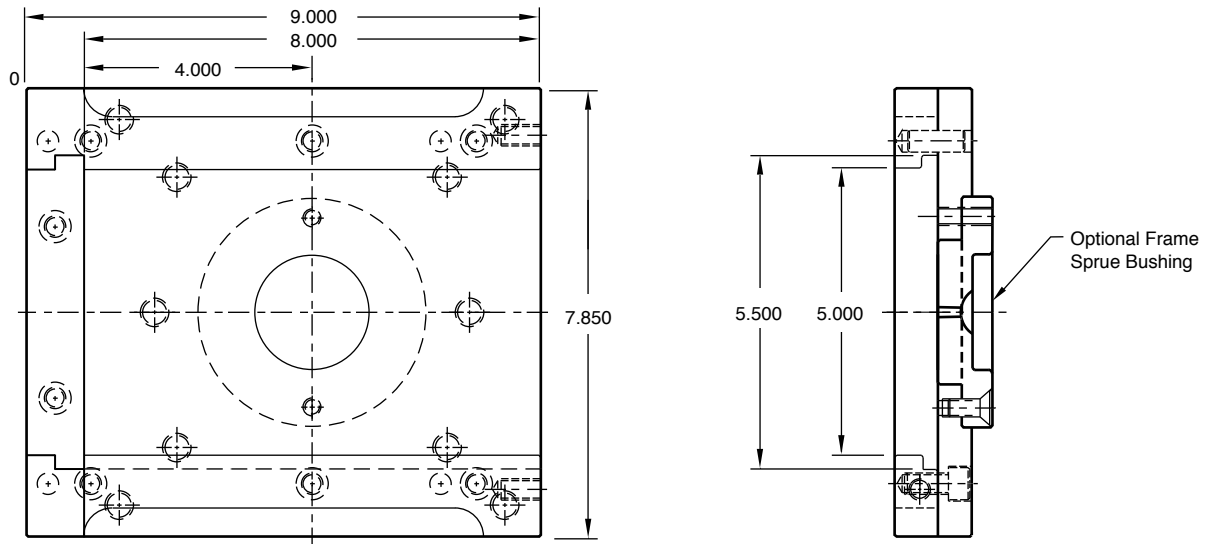
▶ CAD insertion point



RTI 08/09 FRAME

Accepts:

- 5 x 8 Solid Units, RTS-0809 on Page L-2
- 5 x 8 Laminated Units, RTL-0809 on Page L-3 and L-4.
- 7.85 x 9 T-Style Units, RTT-0809 on Page L-6



M Pre-Hard Stainless Steel **H** 32-36 HRC

CATALOG NUMBER	DESCRIPTION
RTF-0809	08/09 Series Frame

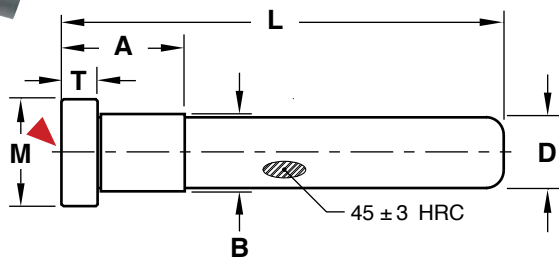
Includes:

- Frame
- Quick Change Clamps (4)

Frame Sprue Bushings are sold separately on page L-9, Sprue Bushings on page B-1, and Locating Rings on B-2.

RTI ACCESSORIES

LEADER PINS



M AISI 1117 **H** Surface: 58-62 HRC

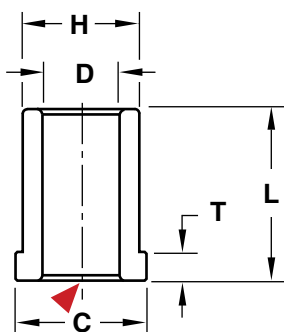
L	D=1/2"	D=5/8"
1.250	RLP50L1.25	—
1.750	RLP50L1.75	RLP62L1.75
2.000	RLP50L2.00	—
2.250	RLP50L2.25	RLP62L2.25
2.500	RLP50L2.50	RLP62L2.50
3.000	RLP50L3.00	RLP62L3.00
3.500	RLP50L3.50	RLP62L3.50
4.000	—	RLP62L4.00

NOMINAL DIAMETER	D +.0000 -.0005	A +.00 -.03	B +.0005 -.0000	M +.00 -.01	T +.000 -.002
1/2	.499	.75	.500	.750	.250
5/8	.624	.87	.625	.865	.250

Note: The RLP50L1.25 has an "A" dimension of .62".

▶ CAD insertion point

SHOULDER BUSHINGS



M CA954 Solid Bronze **H** 170 Brinell

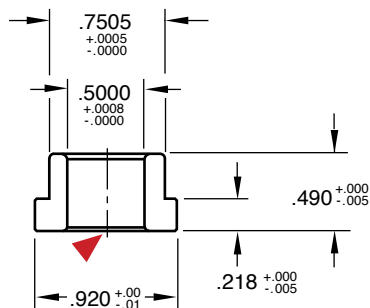
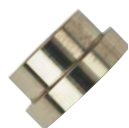
NOMINAL PLATE THICKNESS	L	D=1/2"	D=5/8"
.625	.625	RSB50L.62	—
.875	.875	—	RSB62L.87
1.000	.900	RSB50L1.00	—
1.125	1.125	RSB50L1.12	—
1.250	1.150	—	RSB62L1.25
1.375-S	1.275	RSB50L1.27	RSB62L1.27
1.375	1.375	—	RSB62L1.37
1.500	1.400	RSB50L1.50	RSB62L1.50
1.625	1.625	RSB50L1.62	—
1.875-S	1.775	RSB50L1.87	RSB62L1.77
1.875	1.875	—	RSB62L1.87
2.375	2.275	RSB50L2.37	RSB62L2.37
2.875	2.775	—	RSB62L2.87

NOMINAL DIAMETER	D +.0008 -.0000	H +.0005 -.0000	C +.000 -.005	T +.000 -.005
1/2	.5000	.7505	.863	.188
5/8	.6250	.8755	1.100	.188

▶ CAD insertion point

Note: The "-S" signifies use with Solid inserts.

GUIDE PIN BUSHINGS



M CA954 Solid Bronze **H** 170 Brinell

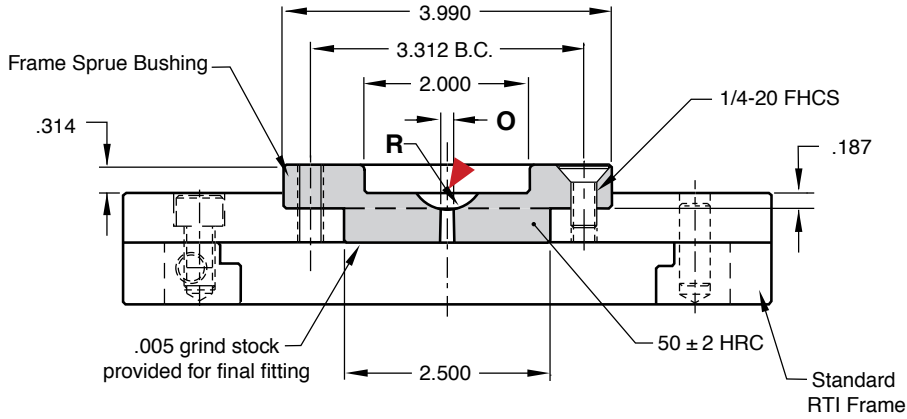
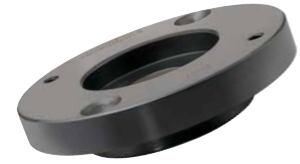
CATALOG NUMBER	DESCRIPTION
RGE50	1/2" ID Guided Ejector Bushing

▶ CAD insertion point



RTI ACCESSORIES

FRAME SPRUE BUSHINGS



M H-13 **S** Melonite (SBN)

CATALOG NUMBER	O	R
RFS-512	5/32	1/2
RFS-534	5/32	3/4
RFS-712	7/32	1/2
RFS-734	7/32	3/4
RFS-912	9/32	1/2
RFS-934	9/32	3/4

Screws included.

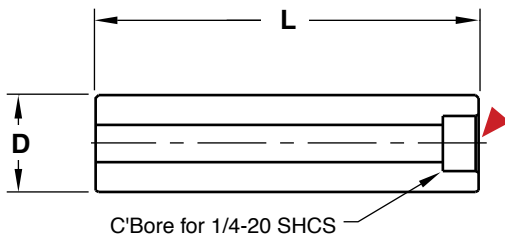
SUPPORT PILLARS



Counterbored

M AISI 1018 **H** 126 Brinell

▶ CAD insertion point

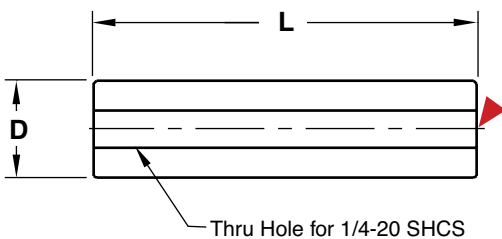


D	CATALOG NUMBER	L +.002 +.000	SCREW LENGTH (1/4-20 SHCS)
3/4	RSP75L2.1	2.125	2.25
	RSP75L2.6	2.625	2.75
	RSP75L3.5	3.500	3.75
1	RSP100L2.1	2.125	2.25
	RSP100L2.6	2.625	2.75
	RSP100L3.5	3.500	3.75
1-1/4	RSP125L2.1	2.125	2.25
	RSP125L2.6	2.625	2.75
	RSP125L3.5	3.500	3.75

Screw included.

Clearance Hole

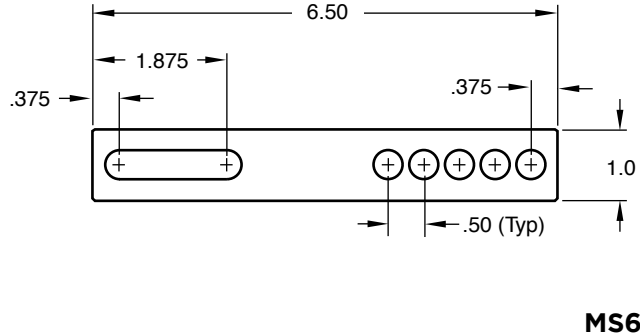
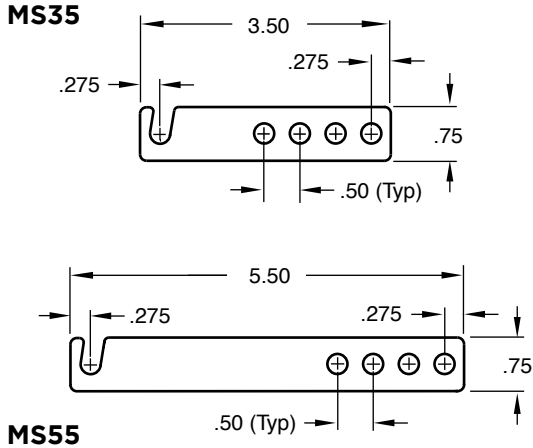
M AISI 1018 **H** 126 Brinell



CATALOG NUMBER	D	L +.001 +.000	SCREW LENGTH (1/4-20 SHCS)
RSP75L1.8	3/4	1.813	2.75
RSP75L2.7		2.688	3.75

Screw included.

RTI ACCESSORIES
STRAPS

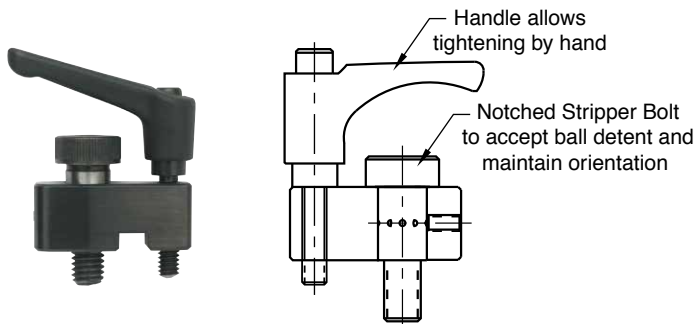


M MS35 & MS55: Polycarbonate, MS65: AISI 1018

CATALOG NUMBER	DESCRIPTION	THICKNESS
MS35	3.5" Long RTI Strap	.200
MS55	5.5" Long RTI Strap	.200
MS65	6.5" Long Heavy Duty Strap	.500

MS35 & MS55 include 1/4-20 thumb screw.
MS65 includes (2) 3/8-16 x 1" long SHCS.

FRAME CLAMPS



CATALOG NUMBER	DESCRIPTION
RFC-100	RTI Frame/Insert Clamp (Sold Individually)

T-HANDLES



CATALOG NUMBER	DESCRIPTION
T100	RTI T-Handle

Designed for inserts less than 75 pounds.



TOOLROOM INNOVATIONS

SECTION M



RhinoFeet™	RhinoToes™	Fin Tip Nozzles	Nozzle Caddy/Wrench
Prefix: RHF	Prefix: RHT	Prefix: NZFT	Prefix: NZLCAD, NZLWR
Page: M-1	Page: M-1	Page: M-2	Page: M-3



Toolroom Bench	Status Tags	Mold Finish Guides	Mold Light Bar
Prefix: TRB	Prefix: ST	Prefix: LIT	Prefix: MLB, MLBTF
Page: M-4	Page: M-6	Page: M-7	Page: M-8



Synthetic Grease
Prefix: SYN
Page: M-8

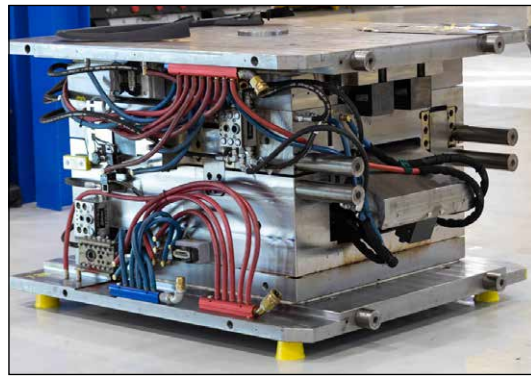
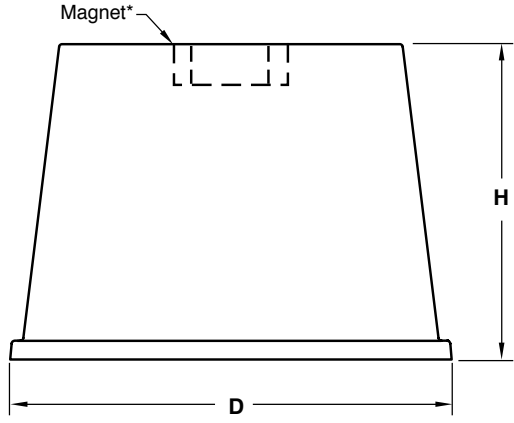


RHINOFEET™



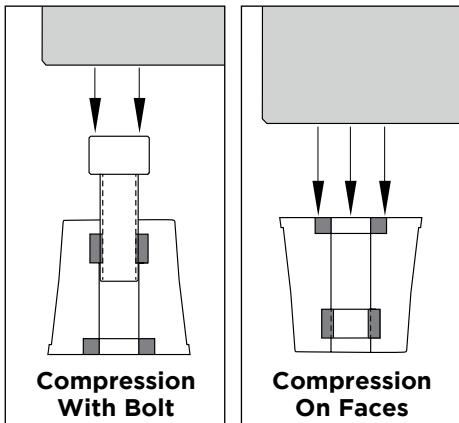
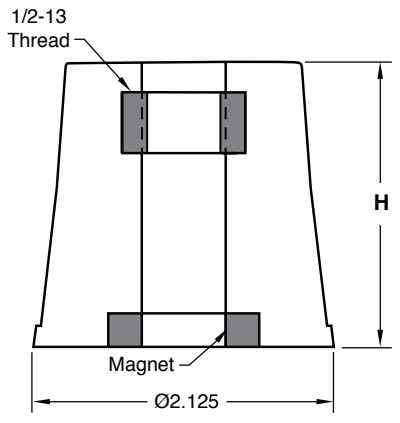
Progressive offers the RhinoFeet product line to eliminate the hazards associated with placing molds and plates on wood blocks and pallets.

- Safer, cleaner, and improves 5S standards within the shop.
- 7,000 lbs (3,000 kg) or 15,000 lbs (7,000 kg) safe working loads, with a safety factor of 3.
- Height and load is marked on the feet for easy identification.



CATALOG NUMBER INCH	CATALOG NUMBER METRIC	D	H	SAFE WORKING LOAD (LBS/KG)
RHF2	RHF50	4.12" / 104mm	2" / 50mm	7,000 / 3,000
RHF3	RHF75	4.12" / 104mm	3" / 75mm	7,000 / 3,000
RHF4	RHF100	4.12" / 104mm	4" / 100mm	7,000 / 3,000
RHF5	RHF125	5.43" / 140mm	5" / 125mm	15,000 / 7,000

*Note: The RHF5/RHF125 has 2 magnets.



RHINOTOES™



CATALOG NUMBER	H	COMPRESSION WITH BOLT SAFE WORKING LOAD (LBS/KG)	COMPRESSION ON FACES SAFE WORKING LOAD (LBS/KG)
RHT1	1"	630 / 286	2,500 / 1,000
RHT2	2"	800 / 363	2,500 / 1,000
RHT3	3"	830 / 377	2,500 / 1,000

APPLICATION GUIDELINES

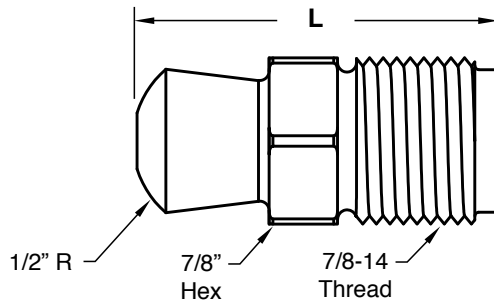
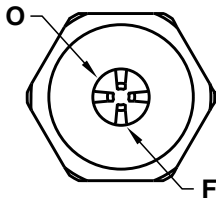
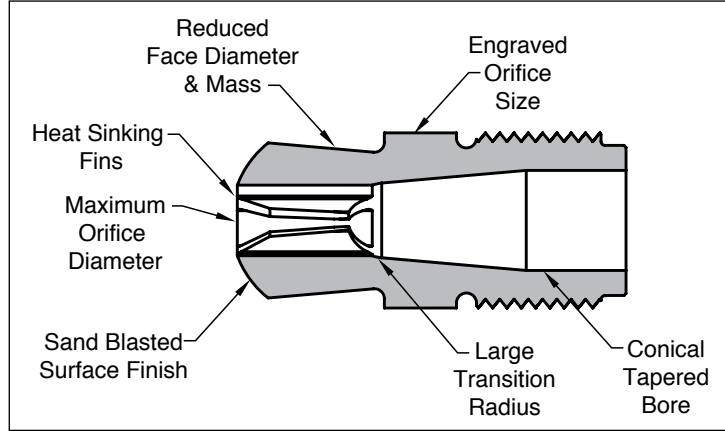
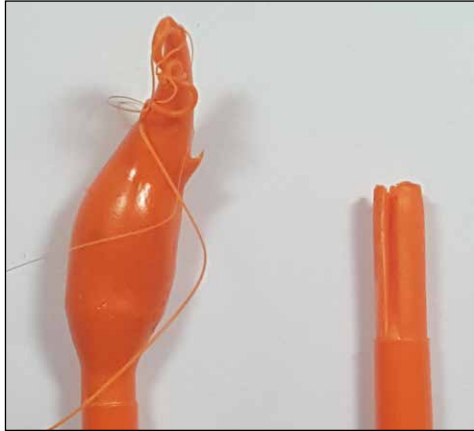
- RhinoToes are utilized to support a plate or hot runner system for bench work or storage.
- Use with a 1/2-13 bolt or threaded rod for additional heights and plate separation.
- Toes have a safety factor of 3.
- Mold maker to supply 1/2-13 threaded rod or bolt.

NOZZLES
FIN TIP



The Fin Tip Nozzles provide the best solution to prevent mold-damaging strings. This patented new design dramatically reduces the solidification time, the root cause of string formation.

- No need to increase cycle times, use smaller orifice sizes, or nozzle tips with restrictive internal bores in order to stop nozzle stringing.
- Proven successful with commodity and engineering grade materials, both filled and unfilled.



M 420 Stainless Steel **H** 48-50 HRC

CATALOG NUMBER	O NOMINAL	O ACTUAL	F QTY FINS	L
NZFT156	5/32	.148	3	1.794
NZFT187	3/16	.178	3	1.817
NZFT219	7/32	.207	4	1.839
NZFT250	1/4	.236	4	1.886
NZFT281	9/32	.265	4	1.881
NZFT312	5/16	.295	4	1.903
NZFT344	11/32	.324	4	1.923
NZFT375	3/8	.353	4	1.943

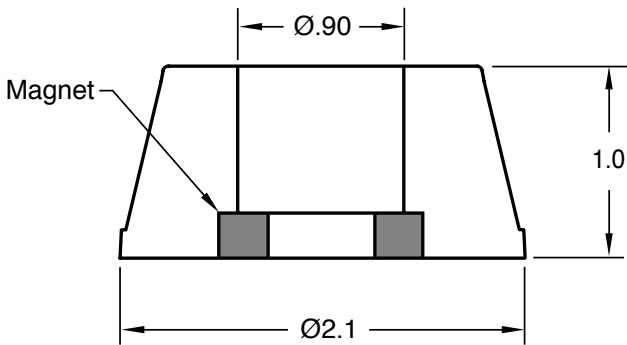
APPLICATION GUIDELINES

- Heat-conducting thermal fins extend 75% into the melt stream, for rapid solidification.
- Reduced tip mass provides faster thermal equilibrium and shorter cycle times.
- Flow area equivalent to Full Flow style tips, for minimal increase in shear and pressure.
- Orifice sizes are slightly smaller than nominal. There is no need to use a 1/32" smaller tip.
- Hardened 420 stainless steel for corrosion resistance and long life.
- Large internal transition radius virtually eliminates "dead spots" where material can stagnate.
- Reduced face diameter increases machine's nozzle touch force, reduces blowback, and eliminates the need for nozzle insulators.
- The 1/2" nozzle radius is actually 0.496". Together with the sand blasted surface finish, it ensures a proper seal with the sprue bushing, which prevents material leaks and air infiltration.
- Land lengths vary with the orifice size. The larger the orifice, the longer the land length, for increased thermal conductivity.
- Engraved orifice size helps reduce mold set-up time.



NOZZLE CADDIE

Progressive offers a caddy to keep the Fin Tip and other machine Nozzles on the press, close to the tools.



CATALOG NUMBER	DESCRIPTION
NZLCAD1	Machine Nozzle Caddy (Blue)

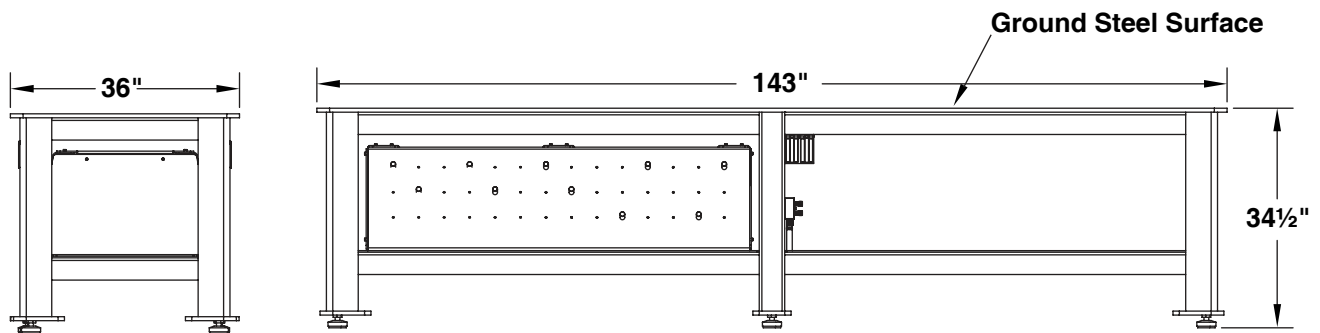
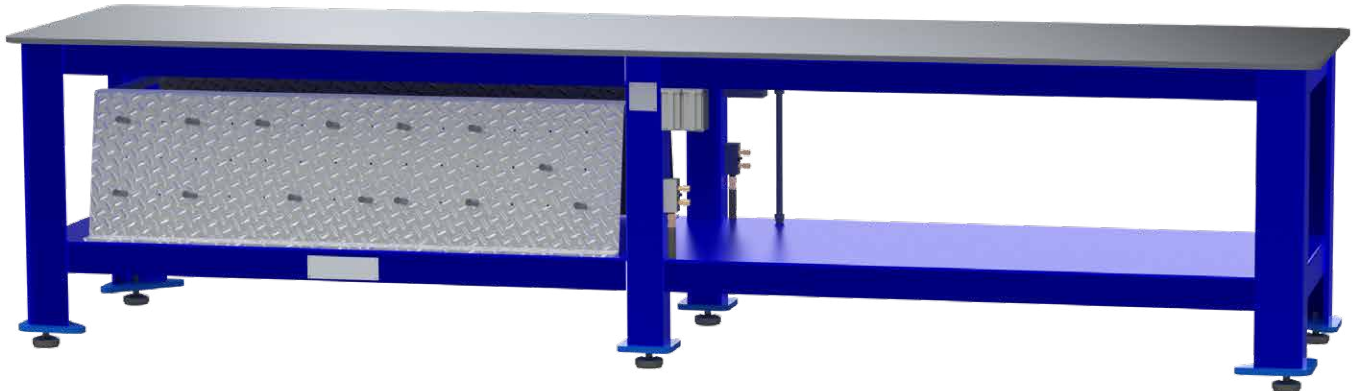
NOZZLE WRENCH



M Steel **S** Zinc Phosphate

CATALOG NUMBER	DESCRIPTION
NZLWR1	7/8" Hex Offset Wrench

TOOLROOM BENCH



Bench Optimized for Mold Assembly/Disassembly:

- More efficient mold assembly and disassembly
- Convenient working height
- Shelf for storage
- 3/4" thick Blanchard Ground steel work surface for smooth and easy positioning of mold plates
- Radiused corners on legs to reduce knee injuries
- Bench is all-welded construction
- Max static load rating is 30,000 lbs



Standardized Design:

- Adopt best practices across your facility
- Consistent so all work areas are equal

Tool Storage Option:

- Easy access to tools needed on the bench
- Prevent clutter
- Pre-drilled holes and repositionable aluminum pegs for organized and flexible tool storage
- Tool Storage unit fits under one section of the bench
- 1/4" steel, black powder coated
- Recessed 2" from shelf edge and angled back to keep tools in place
- Each tool storage unit includes one board on each side of bench

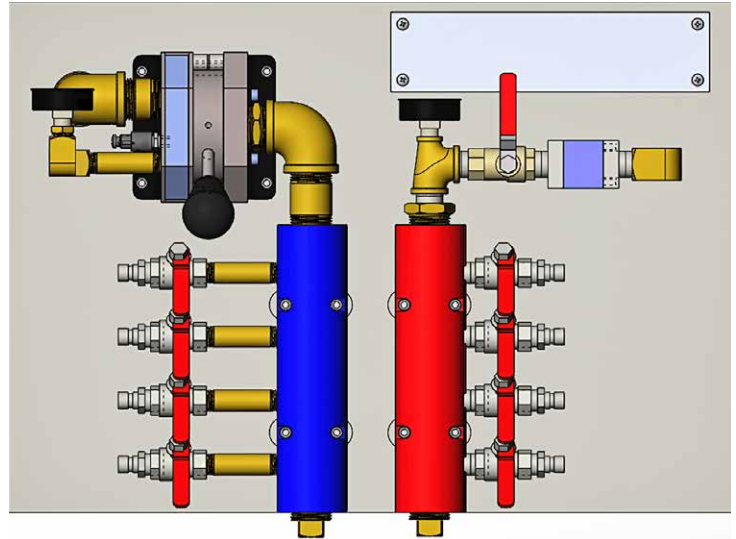




TOOLROOM BENCH

Water Manifold and Flow Meter Option:

- Manifold and valves allow quick connection for mold water testing
- Flow meter can be used to ensure flow is even and there are no restrictions
- Ability to bench test for leaks saves valuable time versus testing in the press
- Red and blue manifold similar to what is at the press
- Convenient drain feature provides cleaner, more efficient drainage after testing

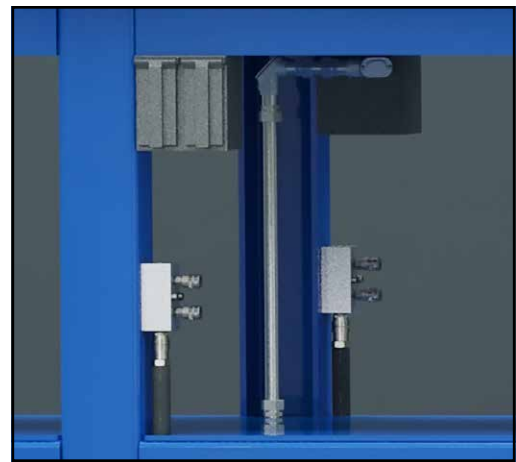


Air Manifold Option:

- Convenient connection of air tools
- One on each side of the bench
- Hooks to hold air hose

Electrical Option:

- 2 outlets on either side of the bench
- Electrical hookups are routed under the bench to minimize obstructions
- Positioned centrally on bench for easy access



To Order:

TRB34	-	F	T	A	E
-------	---	---	---	---	---

Options:

F = Manifold and Flow Meter

T = Tool Storage

A = Air

E = Electrical

Note: Standard Toolroom Bench dimensions are 3' wide, by 12' long and 34" high.

Examples:

TRB34-FTAE = Toolroom Bench with all options installed

TRB34-AE = Toolroom Bench with Air and Electrical options installed

STATUS TAGS

APPLICATION GUIDELINES

- Status Tags magnetically attach to molds and are color-coded for easy identification of mold status at a glance.
- 3.75" Diameter.
- Magnetic back.
- Laminated vinyl surface.
- Sold in packages of 12 tags.



CATALOG NUMBER	COLOR	DESCRIPTION
ST-GRE	Green	Ready to Run
ST-YEL	Yellow	Qualify Mold / Sample
ST-RED	Red	Do Not Run Mold / Repair
ST-ORN	Orange	Maintenance Required
ST-WHT	White	Operator Required
ST-BLK	Black	Obsolete Mold



MOLD FINISH GUIDE



FEATURES

- Molded, ABS plastic plaque, 8-1/2 x 11, showing typical finishes to aid in communication with customers.
- Includes A-1, A-2, A-3, B-1, B-2, B-3, C-1, C-2, C-3, D-1, and D-3 finishes.
- Provided by the Society of Plastics Industry

CATALOG NUMBER

LIT-MFC

LOCATING RING SHIMS



M 316 Stainless Steel

CATALOG NUMBER	THICKNESS
LRS-02	.002"
LRS-03	.003"
LRS-05	.005"

APPLICATION GUIDELINES

- Shims allow for pre-loading the flanged Locating Rings to compensate for a worn or dished platen as well as compensate for high injection pressures in the center of the mold.
- Three thicknesses to enable preload for the center of the mold.
- Sold individually to accommodate stacking requirements.
- Sized with screw clearances for use with flanged Locating Rings sold on page B-3.

MOLD LIGHT BAR

Mold Light Bars provide illumination at the molding press to reduce eye strain and increase visibility for operators and repair technicians.

Light Bar Technical Information:

- Wire direct to 24V machine power or optional transformer
- Mounts to press platen magnetically to direct light on mold
- 12w 450mA

Light Bar Product Information:

- Six LED floodlights per unit. Rated for 50,000 hours
- Aluminum casting with tempered glass is water and shock resistant
- 45° and 90° swivel mounting brackets included
- IP67 Rated

Transformer Information:

- Plugs directly into 110v outlet
- Two screw wire connection



CATALOG NUMBER	DESCRIPTION	VOLTAGE	LENGTH	WIDTH
MLB2X16	Light Bar	24V	16"	2"
MLBTF	Transformer	110V 24V	—	—

SYNTHETIC MOLD GREASE



APPLICATION GUIDELINES

- Premium synthetic mold grease provides superior lubrication to sliding or moving components within molds and tooling.
- Engineered for food and medical molding environments
- Low migration
- Should only be applied in a thin layer by hand
- NSF H1 Registered
- Thermally stable to 570°F (300°C)

CATALOG NUMBER	DESCRIPTION
SYN-100	100g Tube
SYN-500	500g Tin